



**DIAMOND CORE
DRILLING MOTOR
OPERATORS MANUAL**

**MODEL
CB515**

AUG 2018

Intentionally Blank

DIAMOND CORE DRILLING MACHINE

ORIGINAL INSTRUCTIONS

For your personal safety, **READ** and **UNDERSTAND** before using.

SAVE THESE INSTRUCTIONS FOR FUTURE REFERENCE.



CE CB



Warning:

On tools equipped with over load protection, when motor has been cut off due to over load, always switch on machine with no load for at least 3 minutes to reduce temperature before returning to operation to avoid burn out of the motor.

TECHNICAL DATA

Model	CB515	
Power Input	1800W, 15A	
Voltage	115V~ 50-60Hz	
No Load /Full Load min ⁻¹	Speed 1	1500 / 780
	Speed 2	2500 / 1400
Capacity-Wet	5-1/4" (132mm)	
Arbor Thread	1-1/4" UNC male & 1/2" BSP female	
Neck Diameter	60mm	
Protection Class	Class I with PRCD / GFCI	
Dimensions (L x W x H)	17.7" x 4.1" x 11"	
Net Weight	10.6 Lbs (4.8 kg)	

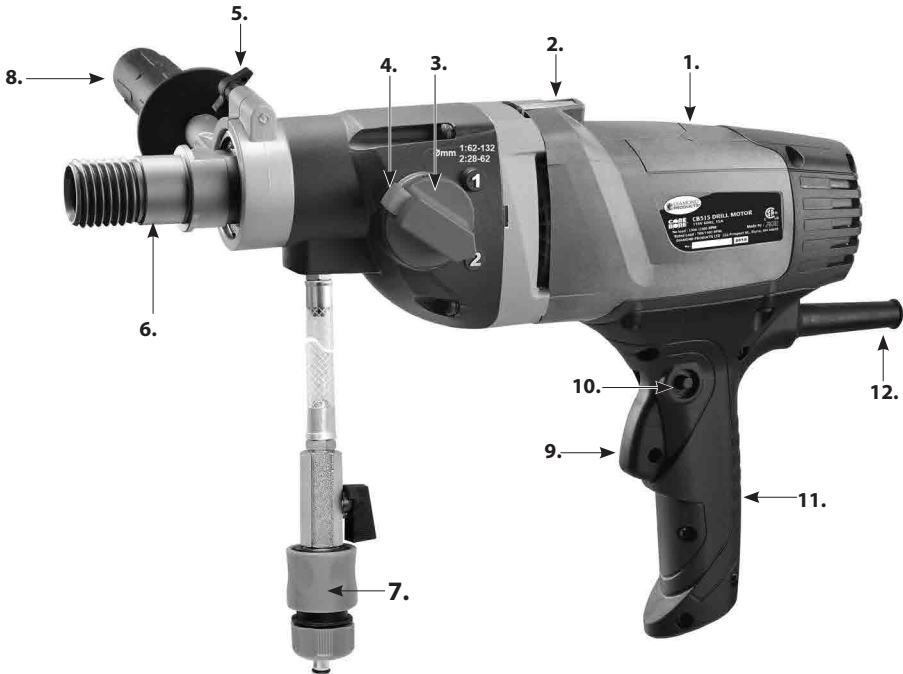

- | | |
|-----------------------------|------------------------|
| 1. Motor | 7. Water Feed Valve |
| 2. Tubular Spirit Level | 8. Side Handle |
| 3. Gear Selector | 9. Trigger Switch |
| 4. Release Button | 10. Lock Button |
| 5. Lock Screw (Side Handle) | 11. Main Handle |
| 6. Spindle | 12. Power Supply Cable |

General Safety Rules



WARNING! Read all safety warnings and all instructions. Failure to follow the warnings and instructions may result in electric shock, fire and/or serious injury.

Save all warnings and instructions for future reference.

The term “power tool” in the warnings refers to your mains-operated (corded) power tool or battery-operated (cordless) power tool.

1. WORK AREA SAFETY

- a. **Keep work area clean and well lit.** Cluttered and dark areas invite accidents.
- b. **Do not operate power tools in explosive atmospheres, such as in the presence of flammable liquids, gases or dust.** Power tools create sparks which may ignite the dust or fumes.
- c. **Keep children and bystanders away while operating a power tool.** Distractions can cause you to lose control.
- d. **Never leave the electric power tool unattended.** Only leave the machine when the tool in use has come to a complete standstill.

2. ELECTRICAL SAFETY

- a. **Power tool plugs must match the outlet. Never modify the plug in any way. Do not use any adapter plugs with earthed (grounded) power tools.** Unmodified plugs and matching outlets will reduce risk of electric shock.
- b. **Avoid body contact with earthed or grounded surfaces, such as pipes, radiators, ranges and refrigerators.** There is an increased risk of electric shock if your body is earthed or grounded.
- c. **Do not expose power tools to rain or wet conditions.** Water entering a power tool will increase the risk of electric shock.
- d. **Do not abuse the cord. Never use the cord for carrying, pulling or unplugging the power tool. Keep cord away from heat, oil, sharp edges or moving parts.** Damaged or entangled cords increase the risk of electric shock.
- e. **When operating a power tool outdoors, use an extension cord suitable for outdoor use.** Use of a cord suitable for outdoor use reduces the risk of electric shock.
- f. **If operating a power tool in a damp location is unavoidable, use a residual current device (RCD) protected supply.** Use of an RCD reduces the risk of electric shock.

3. PERSONAL SAFETY

- a. **Stay alert, watch what you are doing and use common sense when operating a power tool. Do not use a power tool while you are tired or under the influence of drugs, alcohol or medication.** A moment of inattention while operating power tools may result in serious personal injury.
- b. **Use personal protective equipment. Always wear eye protection.** Protective equipment such as dust mask, non-skid safety shoes, hard hat, or hearing protection used for appropriate conditions will reduce personal injuries.

- c. **Prevent unintentional starting. Ensure the switch is in the off-position before connecting to power source and/or battery pack, picking up or carrying the tool.** Carrying power tools with your finger on the switch or energising power tools that have the switch on invites accidents.
- d. **Remove any adjusting key or wrench before turning the power tool on.** A wrench or a key left attached to a rotating part of the power tool may result in personal injury.
- e. **Do not overreach. Keep proper footing and balance at all times.** This enables better control of the power tool in unexpected situations.
- f. **Dress properly. Do not wear loose clothing or jewellery. Keep your hair and clothing away from moving parts.** Loose clothes, jewellery or long hair can be caught in moving parts.
- g. **If devices are provided for the connection of dust extraction and collection facilities, ensure these are connected and properly used.** Use of dust collection can reduce dust-related hazards.
- h. **Do not let familiarity gained from frequent use of tools allow you to become complacent and ignore, tool safety principles.** A careless action can cause severe injury within a fraction of a second.

4. POWER TOOL USE AND CARE

- a. **Do not force the power tool. Use the correct power tool for your application.** The correct power tool will do the job better and safer at the rate for which it was designed.
- b. **Do not use the power tool if the switch does not turn it on and off.** Any power tool that cannot be controlled with the switch is dangerous and must be repaired.
- c. **Disconnect the plug from the power source and/or battery pack from the power tool before making any adjustments, changing accessories, or storing power tools.** Such preventive safety measures reduce the risk of starting the power tool accidentally.
- d. **Store idle power tools out of the reach of children and do not allow persons unfamiliar with the power tool or these instructions to operate the power tool.** Power tools are dangerous in the hands of untrained users.
- e. **Maintain power tools. Check for misalignment or binding of moving parts, breakage of parts and any other condition that may affect the power tool's operation. If damaged, have the power tool repaired before use.** Many accidents are caused by poorly maintained power tools.
- f. **Keep cutting tools sharp and clean.** Properly maintained cutting tools with sharp cutting edges are less likely to bind and are easier to control.
- g. **Use the power tool, accessories and tool bits etc. in accordance with these instructions taking into account the working conditions and the work to be performed.** Use of the power tool for operations different from those intended could result in a hazardous situation.
- h. **Keep handles dry, clean and free of oil and grease.** Slippery handles do not allow for safe handling and control of the tool in unexpected situations.

5. SERVICE

- a. **Have your power tool serviced by a qualified repair person using only identical replacement parts.** This will ensure that the safety of the power tool is maintained.
- b. **Only use original parts for repair and maintenance.** The use of incompatible accessories or spare parts can result in electric shocks or other injuries.

Symbols used in this manual

V.....volts

A.....amperes

Hz.....hertz

W.....watt

~.....alternating current

n_0no load speed

min^{-1}revolutions or reciprocation
per minute



.....warning of general danger



.....with electrical earth



.....read these instructions



.....always wear eye protection



.....always wear a dust mask.



.....always wear hearing protection



.....wear safety-approved hard hat



do not dispose of electric tools,
accessories and packaging together
with household waste material

DRILL SAFETY WARNINGS

- **Use auxiliary handles supplied with the tool.** Loss of control can cause personal injury.
- **Hold power tool by insulated gripping surfaces, when performing an operation where the cutting accessory may contact hidden wiring or its own cord.** Cutting accessory contacting a "live" wire may make exposed metal parts of the power tool "live" and could give the operator an electric shock.
- **Never use the machine without the PRCD fault-current safety switch supplied.**
- **Always check the PRCD fault-current safety switch for correct functioning before starting a drilling operation.**
- **Ensure that no water is allowed to get into the motor unit during operation.**
- **If you detect a leak in any part of the water supply system, shut the machine down immediately and repair the fault. Water pressure should not exceed 70 psi (4 bar).**
- **Block off the working area and place warning signs on both sides of the wall when drilling through from one side to the other.**
- **Take appropriate precautions to ensure that, in the event of a drilling core dropping out, no personal injury or material damage will result.**
- **When drilling hollow components, check the flow route of the cooling water in order to prevent damage.**

INTRODUCTION

The machine is equipped with spirit levels which aid in aligning the tool. Use the Bull's Eye Level for vertical aligning and the Tubular Level for horizontal aligning.

This machine is for the intended purpose of diamond core drilling of concrete, masonry, stone and similar materials. The machine may be hand-held for drilling up to 80mm. For sizes above 80mm, it must be mounted on a rig (drilling stand). The rig is not included.

All other uses which are not for the intended purpose are prohibited.

It is equipped with a water feed system which is required for the diamond core drilling process.

It is equipped with a PRCD interrupter (portable residual current device) which must be used at all times. It is equipped with a two speed mechanical gearbox for different core drill size ranges and features a mechanical safety clutch. The motor has electronics for soft start, overload protection and thermal (overheating) protection.

ELECTRICAL CONNECTION

The network voltage must conform to the voltage indicated on the tool name plate.

Under no circumstances should the tool be used when the power supply cable is damaged. A damaged cable must be replaced immediately by an authorized Customer Service Center. Do not try to repair the damaged cable yourself. The use of damaged power cables can lead to an electric shock.

WARNING:

This machine is equipped with a Portable Residual Current Device (PRCD) also known as a Ground Fault Circuit Interrupter (GFCI). Always use this device whenever using the machine to reduce the risk of shock hazards. Test and reset the PRCD device before each use. Press the "Test" button to test. Press the "Reset" button to energize the circuit.

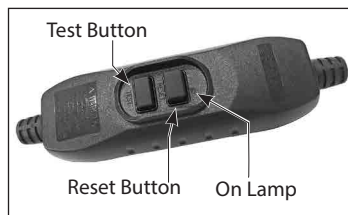

WARNING!: 110V UK machines are not equipped with a PRCD portable residual current device or GFCI ground fault circuit interrupter. The machine must always be used with an isolating transformer for protection in case an electrical fault should occur.

Use an RCD in a separate control box with one or more socket outlets in accordance with EN 60309-2 with the earthing contact position 1 h.

ASSEMBLY

1. Mount the handle clamp of the side handle onto the gearbox neck. Position the side handle perpendicular to the main handle. Use the lock screw to tighten the clamp.
2. Thread the water supply assy. Into the hole in the bottom of gearbox and tighten with a wrench.

LIST OF CONTENTS

- Diamond core drilling machine.
- Side handle assembly
- Water feed assembly
- Wrench

OPERATING INSTRUCTIONS

1) MOUNTING THE CORE BIT

CAUTION: Ensure that the threads of the spindle and the core bit match. Attempting to mount mismatched threads will result in damage to both threads.

The spindle has two types of threads. The outside male thread is 1-1/4inch UNC, the inside female thread is 1/2 inch BSP.

Ensure both the core bit and the machine spindle are clean. Any debris could cause excessive run-out of the mounted core bit. Excessive run-out can cause premature failure of the core bit and/or a safety hazard.

Tighten the bit to the spindle using two wrenches.

Choosing the correct core bit for the job:

Ensure that the bit you are using is suitable for the material you are drilling. There are two main types of diamond core bit:

-Wet bits (Always use water with wet bits)

-Dry bits

2) WATER SUPPLY

Water is a basic requirement for diamond core drilling. The water serves as a coolant to avoid the working surface at the tip of the bit from overheating. To connect the water supply. Attach the quick-release water coupling to a water hose.

WARNING: Check all connections of the water feed system to ensure there are no leaks. Inspect hoses and other critical parts which could deteriorate.

WARNING: The maximum water pressure should not exceed 70 psi (4 bar).

Use a water collector with a wet vacuum to collect cooling water if nearby objects could be damaged by water.

WARNING: Never allow water to enter the motor. A perfectly functioning water collector set up must be used for any drilling performed at an upward angle.

3) SELECTING SPEEDS





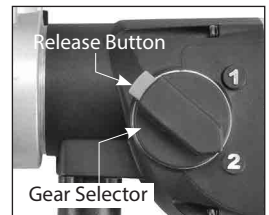
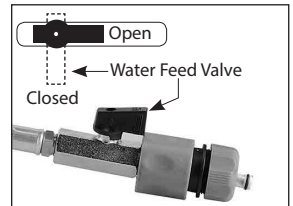

There are 2 speed ranges to suit the bit size and work piece hardness.

CAUTION: Never attempt to change gears on a running machine! Only adjust when the machine is at rest.

Select the desired gear range by pressing the release button and then turning the gear selector either clockwise or counterclockwise into the desired gear. It will usually be necessary to turn the spindle by hand a little to get it to shift all the way.



WET DRILLING RECOMMENDED GEARS (reinforced concrete)

BitØ Gear	1"	2"	2-1/2"	4-1/2"	5-1/2"	>5-1/2"
Gear 2						
Gear 1						



Impossible /
Not recommended



Possible



Ideal

4) THE SWITCH

The machine has a lockable trigger switch. Squeeze the trigger to start the machine. To lock the switch on, press the lock button while holding the trigger switch on. To release, squeeze the trigger and release.

WARNING: Never lock the switch on when drilling hand-held. Only lock the switch on when mounted to a rig.

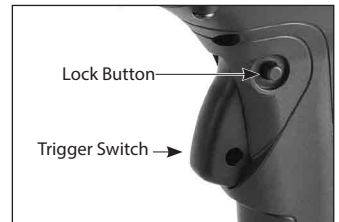

5) OVERLOAD PROTECTION, OVERHEAT PROTECTION

Overload:

If the excessive load is sustained too long, the motor will shut down completely. In this case, the motor must be first shut off and then restarted.

Overheat Thermal Protection:

If the temperature of the motor gets too high, the thermal protection will shut the motor down. The switch must be first shut off and then restarted.

CAUTION: The motor will be damaged if it is repeatedly overloaded or overheated. Always cool the motor . by running at no load for a few minutes whenever it stops from either overheat or overload.

6) SAFETY CLUTCH

This machine is equipped with a mechanical clutch to protect the operator and machine from excessive torque forces. After the clutch slips many times, it will become worn and slip at lower and lower torque levels. When this happens, it must be serviced by an authorized service provider. The recommended torque of the clutch nut is 21 Nm.

7) DIAMOND CORE DRILLING

1. Press the "Reset" button on the PRCD interrupter device to energize the circuit to the machine. Then squeeze the trigger switch to turn the machine on.

2. Open the water valve slightly and very gently begin the cut. If holding by hand, start the cut by approaching at an angle of about 30 degrees to the cutting surface. (A large piece of wood with a large V notch cut in it will help prevent the bit from wandering at the beginning.) Once about a third of the arc is cut, straighten the bit to the correct perpendicular angle while keeping enough feed pressure on the bit to prevent it from wandering.
3. Make adjustments to the water feed as needed. The water leaving the cut should be a solid colored slurry with about the consistency of milk.
4. Once in the cut, use steady feed pressure.
5. When breaking through, hold the machine tightly and reduce feed pressure.

WARNING: Always keep your face away from the machine.

The diamond impregnated segments in a wet type (sintered) diamond core bit operate on a principle of controlled erosion. The bond matrix holding the diamonds is continually worn away by abrasion with the work piece, exposing the harder diamonds to stand proud from the bond matrix.

Without adequate water, the bit would overheat and be destroyed.

With too much water and not enough feed pressure, there would not be adequate erosion of the bond matrix and the bit becomes dull. This is called glazing. If the bit seems to refuse to cut anymore, it is glazed. **See below: "SHARPENING A GLAZED BIT"**

Don't feed too gently or the diamond segments will become glazed. Keep the bit steadily working.

If holding by hand, take great care to keep the bit aligned to the hole. If the bit is crooked, it will easily bind.

If the cut is very deep, the core plug may be obstructing the flow of cooling water. In this case, stop drilling, and chisel out the core plug before continuing.

CAUTION: If the bit gets stuck, do not try to rock it loose by turning the switch on and off. That is hazardous and could damage the motor. Rather, unplug the machine and use a wrench on the bit mounting to work it loose.

If embedded steel such as rebar is encountered take special care. Reduce the feed pressure by about 1/3 and let the bit go at its own pace, if there is too much vibration the bit will be destroyed.

Once the steel is passed, continue normally.

CAUTION: Drilling operations are very stressful to the motor and at the end of the cut, the motor temperature will be very hot, always run the motor at no load for a few minutes until the temperature returns to a normal range before shutting off.

RESHARPENING A GLAZED BIT

If the bit becomes glazed, sharpen by dressing with an appropriate alumina oxide or silicon carbide dressing stone. Simply drill into the stone as many times as necessary to restore its cutting performance.

VIBRATION TROUBLESHOOTING

If vibration occurs and it is not caused by embedded steel, stop drilling to find the cause and remedy.

CAUTION: Do not operate with vibration or there will be serious hazard and the diamond core bit will surely be destroyed.

Vibration is usually caused by:

1. A bit with too much runout
SOLUTION: Replace bit.
2. A bit with diamond segments broken off
SOLUTION: Repair or Replace bit.

MAINTENANCE

Every 50 hours of operation blow compressed air through the motor while running at no load to clean out accumulated dust.

Always check for a damaged power supply cable, check for loose fasteners and always keep alert for unusual noises and vibration when operating.

WARNING: Never operate a damaged machine. Always tag a damaged machine and take it out of service until repairs can be made.

Maintenance which should be performed by an authorized service center, include the following:

- Replace water seals as needed.
- Replace the carbon brushes as needed
- Replace the clutch discs and spring as needed.

THE CARBON BRUSHES

The carbon brushes are a normal wearing part and must be replaced when they reach their wear limit. This machine is equipped with auto-stop carbon brushes. If the machine comes to a stop unexpectedly, the brushes should be checked. The auto-stop brush design protects the motor by stopping the machine before the carbon brushes are completely worn out.

Caution: Always replace the brushes as a pair.

To replace:

1. Remove the 12 screws to open up the handle halves. Carefully move the parts to one side, taking care not to strain the wiring.
2. Using pliers rotate the brush spring out of the way and slide the old carbon brush out of the brush holder.
3. Unscrew the screw to remove the brush lead. The old carbon brush may now be lifted away.
4. Install a new brush. Installation is the reverse of removal.
5. Replace the motor tail cover.

If the replacement of the power supply cord is necessary, this has to be done by the manufacturer or their agent in order to avoid a safety hazard.

WARNING: All repairs must be entrusted to an authorized service center. Incorrectly performed repairs could lead to injury or death.

Do not throw electric power tools into the household waste!

In accordance with the European Directive 2012/19/EU on Waste Electrical and Electronic Equipment and transposition into national law, used electric power tools must be collected separately and recycled in an environmentally friendly manner.

WIRING

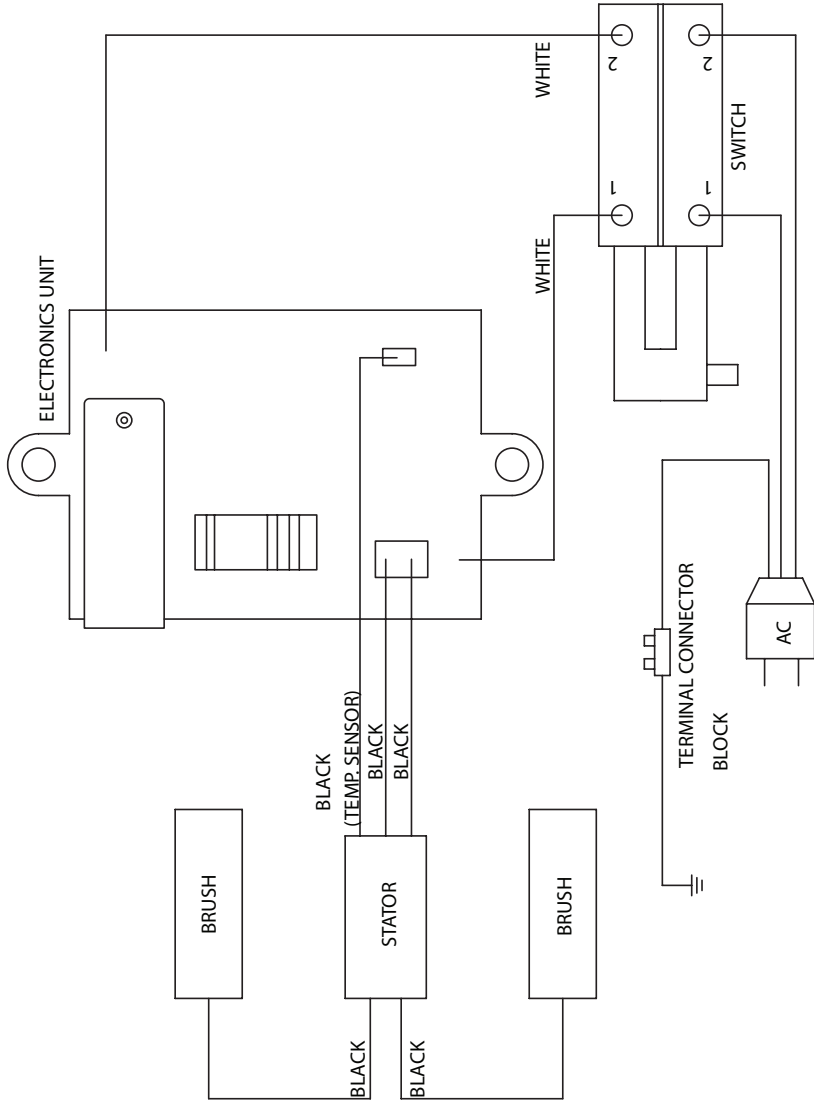

EQUIPMENT AND PARTS WARRANTY

Diamond Products warrants all equipment manufactured by it against defects in workmanship or materials for a period of 90 Days from the date of shipment to Customer. The responsibility of Diamond Products under this Warranty is limited to replacement or repair of defective parts at Diamond Products' Elyria, Ohio factory, or at a point designated by it, of such parts as shall appear to us upon inspection at such parts, to have been defective in material or workmanship, with expense for transportation and labor borne by Customer. In no event shall Diamond Products be liable for consequential or incidental damages arising out of the failure of any Product to operate properly.

THIS WARRANTY IS IN LIEU OF ALL OTHER WARRANTIES, EXPRESSED OR IMPLIED, AND ALL SUCH OTHER WARRANTIES ARE HEREBY DISCLAIMED.



333 Prospect Street, Elyria, Ohio 44035
(440) 323-4616 • (800) 321-5336 • Fax (800) 634-4035
www.diamondproducts.com