



**CORE POWER
PARTS LIST/OPERATOR'S
MANUAL**

**CP22XL
HYDRAULIC POWER UNIT**

MARCH 2023

Part #: 1801397-18

Proposition 65
State of California

Warning !

Engine exhaust and some its constituents are known to the State of California to cause cancer, birth defects, and/or other reproductive harm.

Notification of Spark Arrester Requirement for
State of California

It is a violation of Section 4442 or 4443 to use or operate the engine on any forest-covered, brush-covered, or grass-covered land unless the engine is equipped with a spark arrester, as defined in Section 4442, maintained in effective working order or the engine is constructed, equipped, and maintained for the prevention of fire pursuant to Section 4443.

QUICK REFERENCE

ENGINE FILTERS

AIR, 2708177 (HONDA 17210-Z6L-010)

FUEL, 2703594 (HONDA16910-Z6L-003)

OIL, 2702741 (HONDA 15400-PLM-A01PE)

Table of Contents

<u>Description</u>	<u>Page No.</u>
CP22 Top Level Assembly	4
Hydraulic Schematic.....	10
Hose Kit	11
Fuel Line Routing.....	12
Fuel Tank Assembly	13
Fuel Solenoid with Connector	14
Fuel Solenoid Fuel Line.....	15
Electric Schematic	16
Hydraulic Tank Assembly	18
Front Panel Assembly	20
Oil to Air Cooler Option.....	22
Tool Tray Option	24
Wheel Upgrade Kit (Optional).....	25
Reference Views	26
General Safety Precautions	27
Description & Specifications	29
Hydraulic Fluid	
Control Valve	
Cooler and Radiator	
Hoses	
Operating Instructions	30
Hose Connections	
Engine	
Fuel	
Starting Procedure	
Heating Cold Oil	
Maintaining Oil Temperature	
Shutting Down	
Operating Driven Equipment	31
Maintenance and Troubleshooting	32
Flow & Pressure Ratings, CP Power Packs.....	33

4646190 CP22XL HYDRAULIC POWER SUPPLY

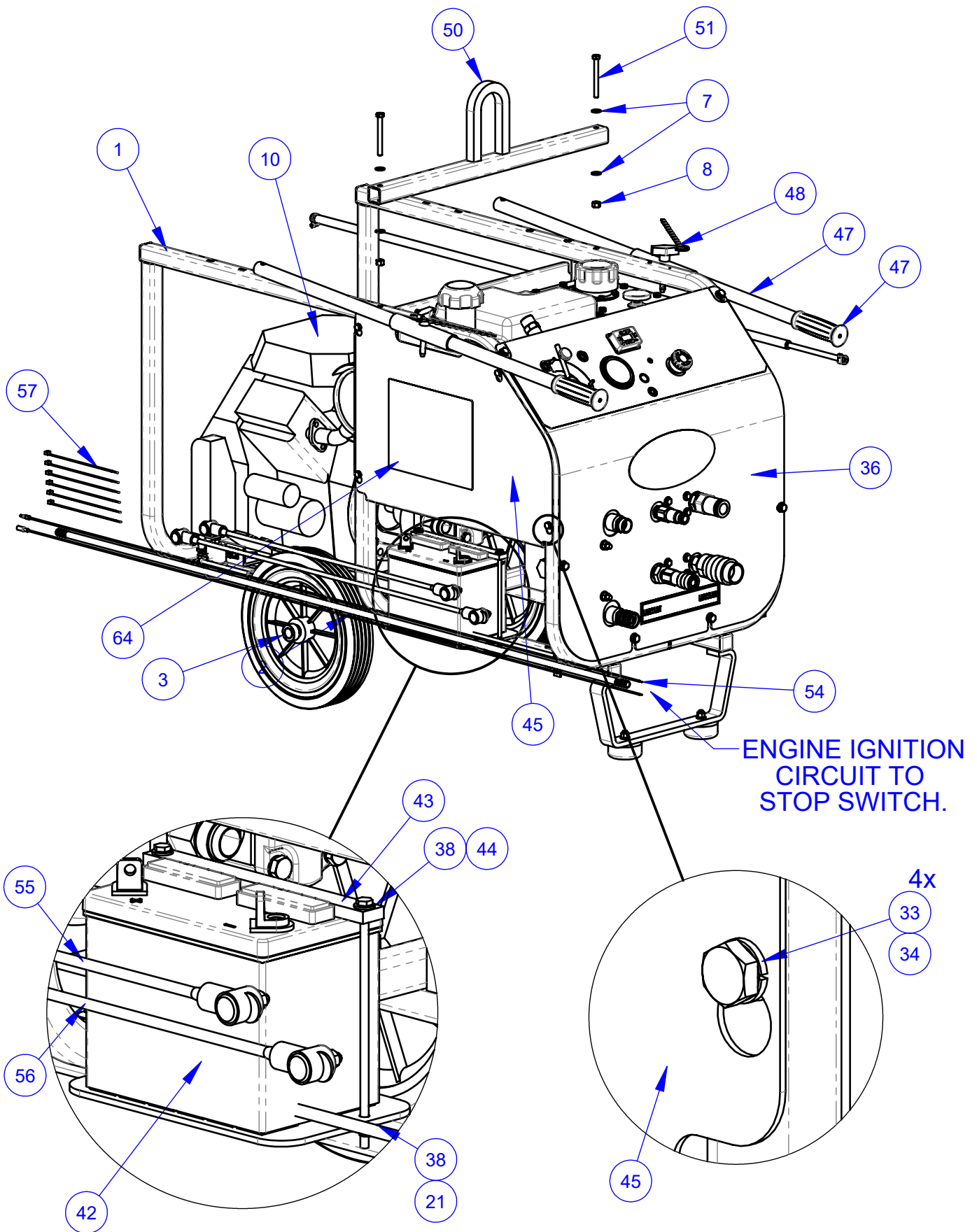

4646190 CP22XL HYDRAULIC POWER SUPPLY

ITEM	PART NO.	QTY.	DESCRIPTION
1	4646156	1	CP-XL Frame Assembly
2	2400643	2	Wheel, 12 x 2-3/8 x 3/4"
3	2400615	2	Set Collar, 3/4"
4	2501767	2	Rubber Bumper
5	2901103	2	Fender Washer, 5/16" x 1"
6	2900508	2	Cap Screw, Hex Hd., 5/16-18 x 1-1/2"
7	2900022	14	Flat Washer, 5/16" SAE
8	2900039	8	Lock Nut, 5/16-18 Nylon
9	4646235	1	Engine Shim Plate
10	4600072	1	Honda Engine, GX690, Short Shaft
11	2900014	8	Flat Washer, 3/8" SAE
12	2900318	4	Cap Screw, Hex Hd., M10-1.5 x 50mm
13	2900304	4	Lock Nut, M10-1.5 Nylon Insert
14	3201968	1	Adapter, M20x1.5 M. to 3/8" F. Pipe
15	3201969	1	Nipple, 3/8 MPT x 2-1/2", Sched. 40, Galv.
16	3202315	1	3/8 NPT Hex Cap
17	2708046	2	Honda Muffler, R Side Exhaust
18	2701670	1	Rectifier Assembly
19	2900009	4	Flat Washer, 1/4" SAE
20	2900052	2	Cap Screw, Hex Hd., 1/4-20 x 1-1/4"
21	2900010	4	Lock Nut, 1/4-20 Nylon
22	4646018	1	Wire Assembly, 12 Gage
23	6048134	1	Key, 1/4" Sq. x 2-1/4"
24	2702225	1	Coupling Assembly, 3/4 - 1-1/8"
25	4646010	1	Pump Mount, SAE 2 Bolt
26	2900006	6	Lock Washer, 3/8" Split
27	2900183	4	Capscrew, Soc Hd., 3/8"-16 X 1-3/8"
28	2600490	1	Hydraulic Pump, .85 CI
29	2900005	2	Cap Screw, Hex Hd., 3/8-16 x 1"
30	3200298	1	Elbow, 3/4" O-Ring to 1/2" M. JIC

ITEM	PART NO.	QTY.	DESCRIPTION
31	3200297	1	Elbow, 1" O-Ring to 1" M. JIC
32	4646011	1	Heat Shield
33	2900024	10	Lock Washer, 1/4" Split
34	2900144	8	Cap Screw, Hex Hd., 1/4-20 x 3/4"
35	4646173	1	Hydraulic Tank Assembly
36	4646189	1	Panel Assembly, CP22 XL
37	4646035	1	Fuel Tank Support
38	2900009	6	Flat Washer, 1/4" SAE
39	2900008	2	Cap Screw, Hex Hd., 1/4-20 x 1"
40	4641099	1	Gas Tank Mounting Plate
41	2900138	4	Cap Screw, Hex Hd., 5/16-18 x 1"
42	2500584	1	Battery, 12 Volt Group Size U1
43	4646122	1	Battery Support
44	2901405	2	Cap Screw, Hex Hd., 1/4-20 x 7-1/2"
45	4646049	1	Side Panel
47	4646006	2	Handle
47	2500636	2	Handle Grip
48	2900257	2	Lock Pin, T Handle, 3/8"
49	2900053	4	Rivet, 3/32" Dia.
50	4646003	1	Lifting Bar
51	2900248	2	Cap Screw, Hex Hd., 5/16-18 x 3"
52	2501434	2	Hose Clamp, 5/8" x 3/4" Wide
53	4641105	1	Vent Hose Assembly
54	4645036	1	Wire Assy., Emergency Off, 65-1/2"
55	4646015	1	Battery Cable Assy., Red
56	4646016	1	Battery Cable Assy., Black
57	2800068	6	Zip Tie, 7-1/2"
58	4646165	1	Hose Kit
59	1800537	1	Label, HOT
60	1801716	1	Decal, EPA EVAP Standard
61	1800169	1	Serial Number Plate, US
62	4600203	1	Gas Tank Assembly, 4.4 Gallon
63	4646244	1	Solenoid Valve Assembly, CP22XL
64	1802758	1	Decal, Core Power CP22

A CATALYTIC MUFFLER IS AVAILABLE: 2702624.

4646190 CP22XL POWER SUPPLY

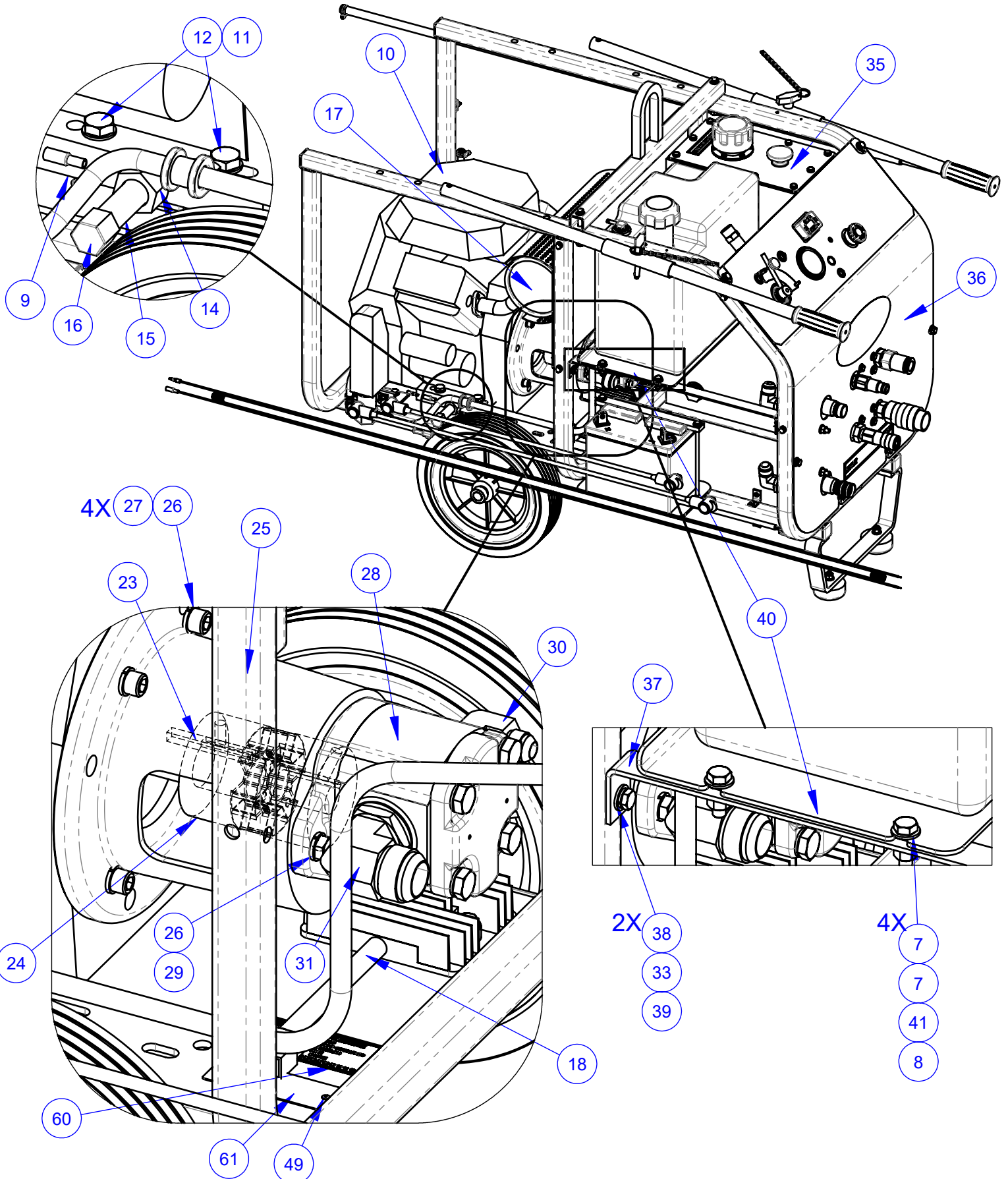

4646190 CP22XL HYDRAULIC POWER SUPPLY

ITEM	PART NO.	QTY.	DESCRIPTION
1	4646156	1	CP-XL Frame Assembly
2	2400643	2	Wheel, 12 x 2-3/8 x 3/4"
3	2400615	2	Set Collar, 3/4"
4	2501767	2	Rubber Bumper
5	2901103	2	Fender Washer, 5/16" x 1"
6	2900508	2	Cap Screw, Hex Hd., 5/16-18 x 1-1/2"
7	2900022	14	Flat Washer, 5/16" SAE
8	2900039	8	Lock Nut, 5/16-18 Nylon
9	4646235	1	Engine Shim Plate
10	4600072	1	Honda Engine, GX690, Short Shaft
11	2900014	8	Flat Washer, 3/8" SAE
12	2900318	4	Cap Screw, Hex Hd., M10-1.5 x 50mm
13	2900304	4	Lock Nut, M10-1.5 Nylon Insert
14	3201968	1	Adapter, M20x1.5 M. to 3/8" F. Pipe
15	3201969	1	Nipple, 3/8 MPT x 2-1/2", Sched. 40, Galv.
16	3202315	1	3/8 NPT Hex Cap
17	2708046	2	Honda Muffler, R Side Exhaust
18	2701670	1	Rectifier Assembly
19	2900009	4	Flat Washer, 1/4" SAE
20	2900052	2	Cap Screw, Hex Hd., 1/4-20 x 1-1/4"
21	2900010	4	Lock Nut, 1/4-20 Nylon
22	4646018	1	Wire Assembly, 12 Gage
23	6048134	1	Key, 1/4" Sq. x 2-1/4"
24	2702225	1	Coupling Assembly, 3/4 - 1-1/8"
25	4646010	1	Pump Mount, SAE 2 Bolt
26	2900006	6	Lock Washer, 3/8" Split
27	2900183	4	Capscrew, Soc Hd., 3/8"-16 X 1-3/8"
28	2600490	1	Hydraulic Pump, .85 CI
29	2900005	2	Cap Screw, Hex Hd., 3/8-16 x 1"
30	3200298	1	Elbow, 3/4" O-Ring to 1/2" M. JIC

A CATALYTIC MUFFLER IS AVAILABLE: 2702624.

ITEM	PART NO.	QTY.	DESCRIPTION
31	3200297	1	Elbow, 1" O-Ring to 1" M. JIC
32	4646011	1	Heat Shield
33	2900024	10	Lock Washer, 1/4" Split
34	2900144	8	Cap Screw, Hex Hd., 1/4-20 x 3/4"
35	4646173	1	Hydraulic Tank Assembly
36	4646189	1	Panel Assembly, CP22 XL
37	4646035	1	Fuel Tank Support
38	2900009	6	Flat Washer, 1/4" SAE
39	2900008	2	Cap Screw, Hex Hd., 1/4-20 x 1"
40	4641099	1	Gas Tank Mounting Plate
41	2900138	4	Cap Screw, Hex Hd., 5/16-18 x 1"
42	2500584	1	Battery, 12 Volt Group Size U1
43	4646122	1	Battery Support
44	2901405	2	Cap Screw, Hex Hd., 1/4-20 x 7-1/2"
45	4646049	1	Side Panel
47	4646006	2	Handle
47	2500636	2	Handle Grip
48	2900257	2	Lock Pin, T Handle, 3/8"
49	2900053	4	Rivet, 3/32" Dia.
50	4646003	1	Lifting Bar
51	2900248	2	Cap Screw, Hex Hd., 5/16-18 x 3"
52	2501434	2	Hose Clamp, 5/8" x 3/4" Wide
53	4641105	1	Vent Hose Assembly
54	4645036	1	Wire Assy., Emergency Off, 65-1/2"
55	4646015	1	Battery Cable Assy., Red
56	4646016	1	Battery Cable Assy., Black
57	2800068	6	Zip Tie, 7-1/2"
58	4646165	1	Hose Kit
59	1800537	1	Label, HOT
60	1801716	1	Decal, EPA EVAP Standard
61	1800169	1	Serial Number Plate, US
62	4600203	1	Gas Tank Assembly, 4.4 Gallon
63	4646244	1	Solenoid Valve Assembly, CP22XL
64	1802758	1	Decal, Core Power CP22

4646190 CP22XL POWER SUPPLY

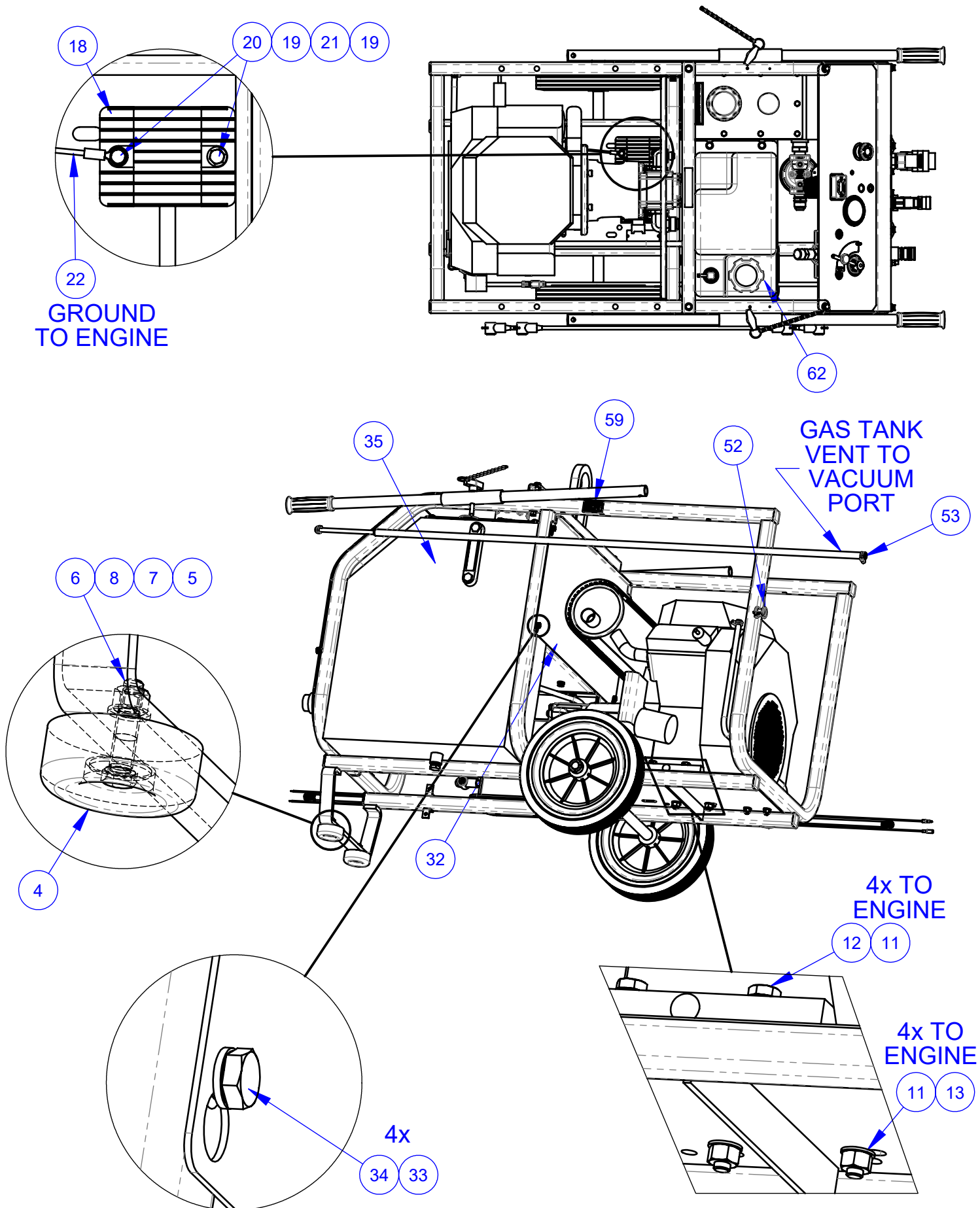

4646190 CP22XL HYDRAULIC POWER SUPPLY

ITEM	PART NO.	QTY.	DESCRIPTION
1	4646156	1	CP-XL Frame Assembly
2	2400643	2	Wheel, 12 x 2-3/8 x 3/4"
3	2400615	2	Set Collar, 3/4"
4	2501767	2	Rubber Bumper
5	2901103	2	Fender Washer, 5/16" x 1"
6	2900508	2	Cap Screw, Hex Hd., 5/16-18 x 1-1/2"
7	2900022	14	Flat Washer, 5/16" SAE
8	2900039	8	Lock Nut, 5/16-18 Nylon
9	4646235	1	Engine Shim Plate
10	4600072	1	Honda Engine, GX690, Short Shaft
11	2900014	8	Flat Washer, 3/8" SAE
12	2900318	4	Cap Screw, Hex Hd., M10-1.5 x 50mm
13	2900304	4	Lock Nut, M10-1.5 Nylon Insert
14	3201968	1	Adapter, M20x1.5 M. to 3/8" F. Pipe
15	3201969	1	Nipple, 3/8 MPT x 2-1/2", Sched. 40, Galv.
16	3202315	1	3/8 NPT Hex Cap
17	2708046	2	Honda Muffler, R Side Exhaust
18	2701670	1	Rectifier Assembly
19	2900009	4	Flat Washer, 1/4" SAE
20	2900052	2	Cap Screw, Hex Hd., 1/4-20 x 1-1/4"
21	2900010	4	Lock Nut, 1/4-20 Nylon
22	4646018	1	Wire Assembly, 12 Gage
23	6048134	1	Key, 1/4" Sq. x 2-1/4"
24	2702225	1	Coupling Assembly, 3/4 - 1-1/8"
25	4646010	1	Pump Mount, SAE 2 Bolt
26	2900006	6	Lock Washer, 3/8" Split
27	2900183	4	Capscrew, Soc Hd., 3/8"-16 X 1-3/8"
28	2600490	1	Hydraulic Pump, .85 CI
29	2900005	2	Cap Screw, Hex Hd., 3/8-16 x 1"
30	3200298	1	Elbow, 3/4" O-Ring to 1/2" M. JIC

ITEM	PART NO.	QTY.	DESCRIPTION
31	3200297	1	Elbow, 1" O-Ring to 1" M. JIC
32	4646011	1	Heat Shield
33	2900024	10	Lock Washer, 1/4" Split
34	2900144	8	Cap Screw, Hex Hd., 1/4-20 x 3/4"
35	4646173	1	Hydraulic Tank Assembly
36	4646189	1	Panel Assembly, CP22 XL
37	4646035	1	Fuel Tank Support
38	2900009	6	Flat Washer, 1/4" SAE
39	2900008	2	Cap Screw, Hex Hd., 1/4-20 x 1"
40	4641099	1	Gas Tank Mounting Plate
41	2900138	4	Cap Screw, Hex Hd., 5/16-18 x 1"
42	2500584	1	Battery, 12 Volt Group Size U1
43	4646122	1	Battery Support
44	2901405	2	Cap Screw, Hex Hd., 1/4-20 x 7-1/2"
45	4646049	1	Side Panel
47	4646006	2	Handle
47	2500636	2	Handle Grip
48	2900257	2	Lock Pin, T Handle, 3/8"
49	2900053	4	Rivet, 3/32" Dia.
50	4646003	1	Lifting Bar
51	2900248	2	Cap Screw, Hex Hd., 5/16-18 x 3"
52	2501434	2	Hose Clamp, 5/8" x 3/4" Wide
53	4641105	1	Vent Hose Assembly
54	4645036	1	Wire Assy., Emergency Off, 65-1/2"
55	4646015	1	Battery Cable Assy., Red
56	4646016	1	Battery Cable Assy., Black
57	2800068	6	Zip Tie, 7-1/2"
58	4646165	1	Hose Kit
59	1800537	1	Label, HOT
60	1801716	1	Decal, EPA EVAP Standard
61	1800169	1	Serial Number Plate, US
62	4600203	1	Gas Tank Assembly, 4.4 Gallon
63	4646244	1	Solenoid Valve Assembly, CP22XL
64	1802758	1	Decal, Core Power CP22

A CATALYTIC MUFFLER IS AVAILABLE: 2702624.

4646190 CP22XL HYDRAULIC SCHEMATIC

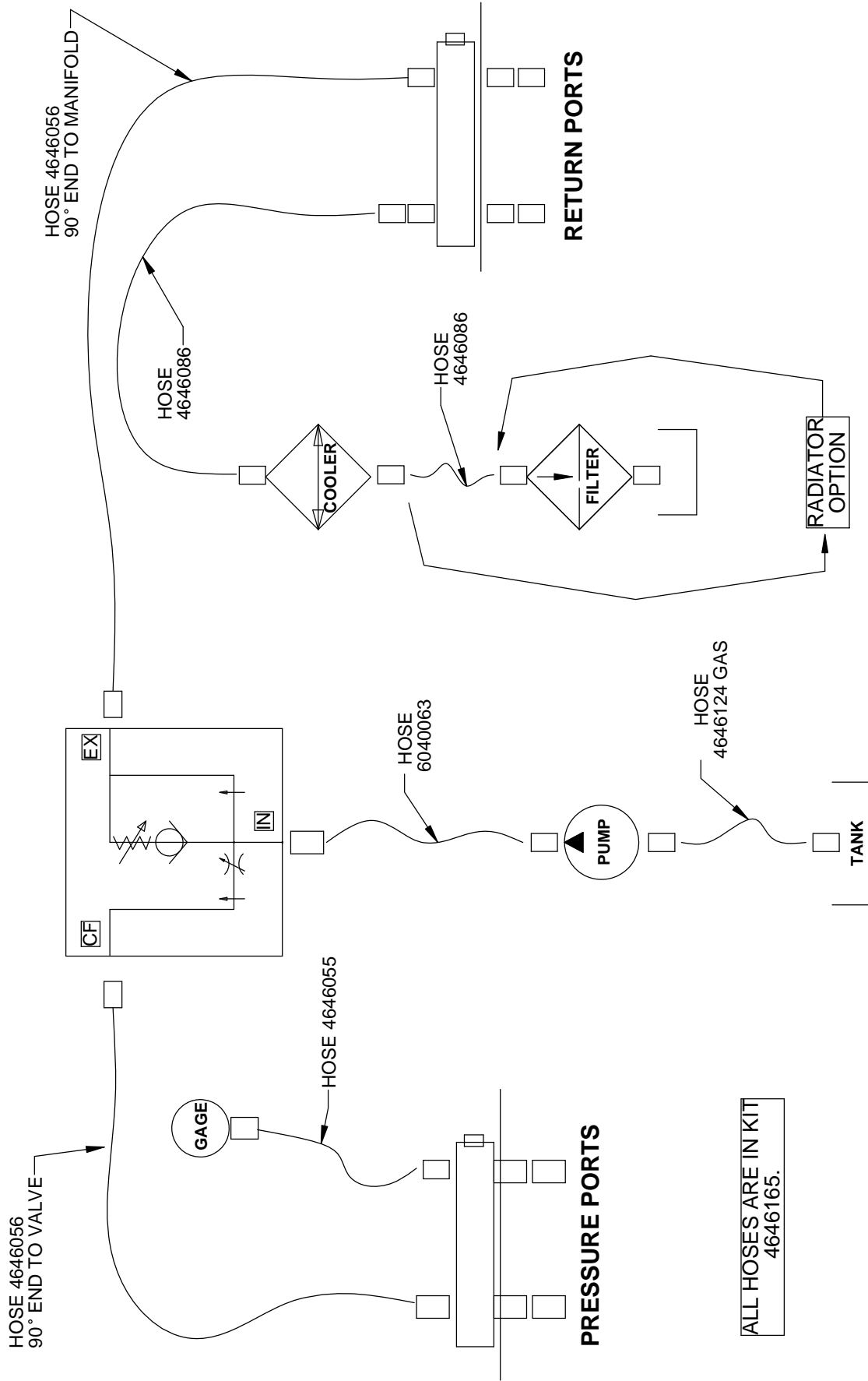

ALL HOSES ARE IN KIT
4646165.

4646165 CP22XL HOSE KIT

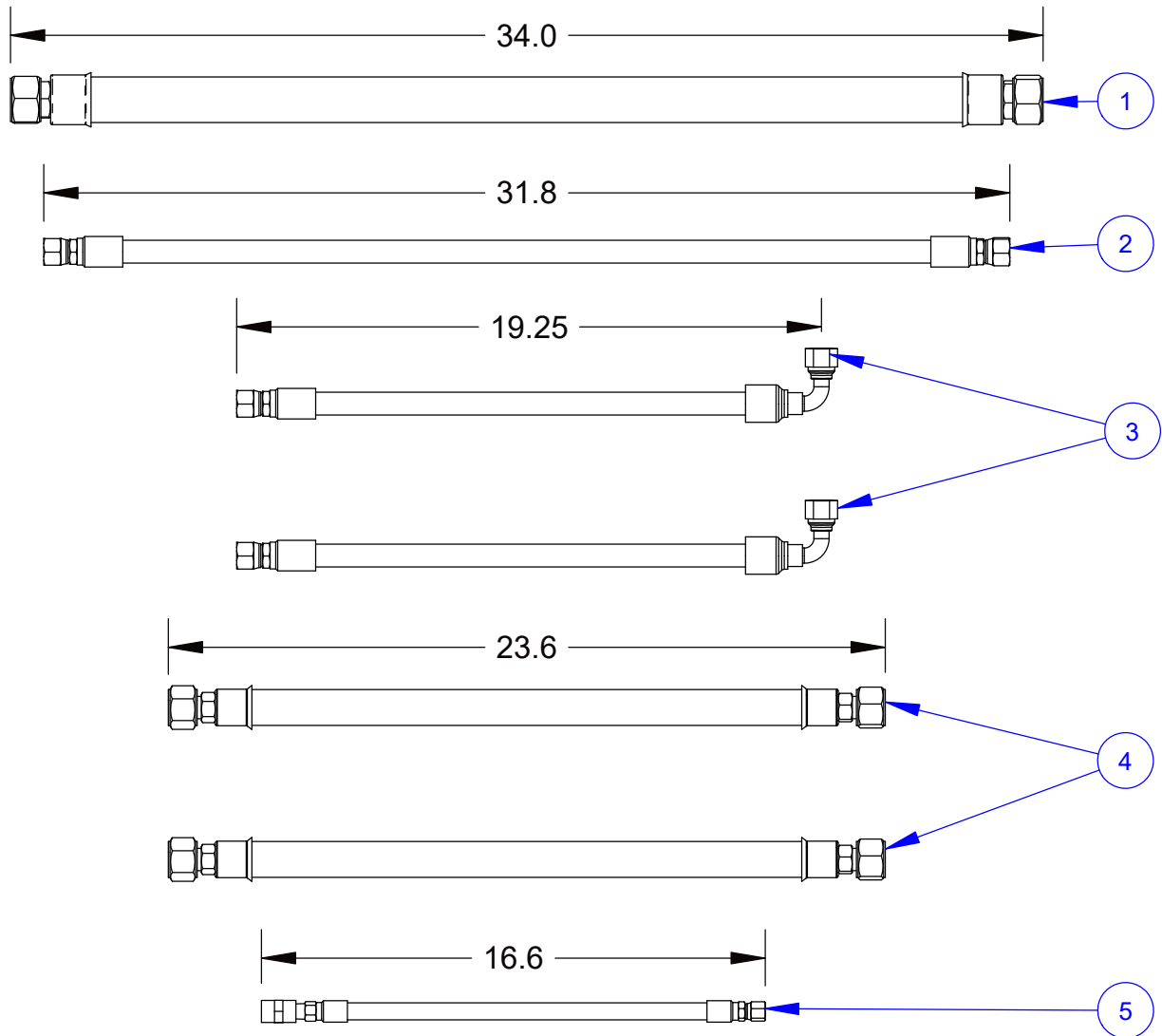

ITEM	PART NO.	QTY.	DESCRIPTION
1	6040057	1	Hose Assy., 1 x 34"
	6040057A	1	1" Hydraulic Hose, Lo Pressure
	3202317	2	Fitting, 1" FJIC to 1" Hose Barb
	3205619	2	Crimp Shell, #16
2	6040063	1	Hose Assembly, 1/2"X 31.8"
	3200290	2	Fitting, 1/2" F. JIC to 1/2" Hose Crimp
3	4646056	2	Hose Assembly, 1/2" X 19-1/4"
	3200290	1	Fitting, 1/2" F. JIC to 1/2" Hose Crimp
	3200408	1	Elbow, 1/2" F. JIC to 1/2" Parkrimp 90 deg.
4	4646086	2	Hose Assembly, 3/4" x 23.6"
	3201989	2	Fitting, 3/4" F.JIC to 3/4" Hose Barb
	3202708	2	Crimp Shell, #12
5	4646055	1	Hose Assembly, 1/4" x 16.6"
	3200128	1	Fitting, 1/4" F. JIC to 1/4" Hose Crimp
	3200145	1	1/4 MPT - 1/4 Hose Crimp
	3201110	1	Coupling, 1/4" NPT

4646190 CP22XL FUEL SYSTEM VENT HOSE

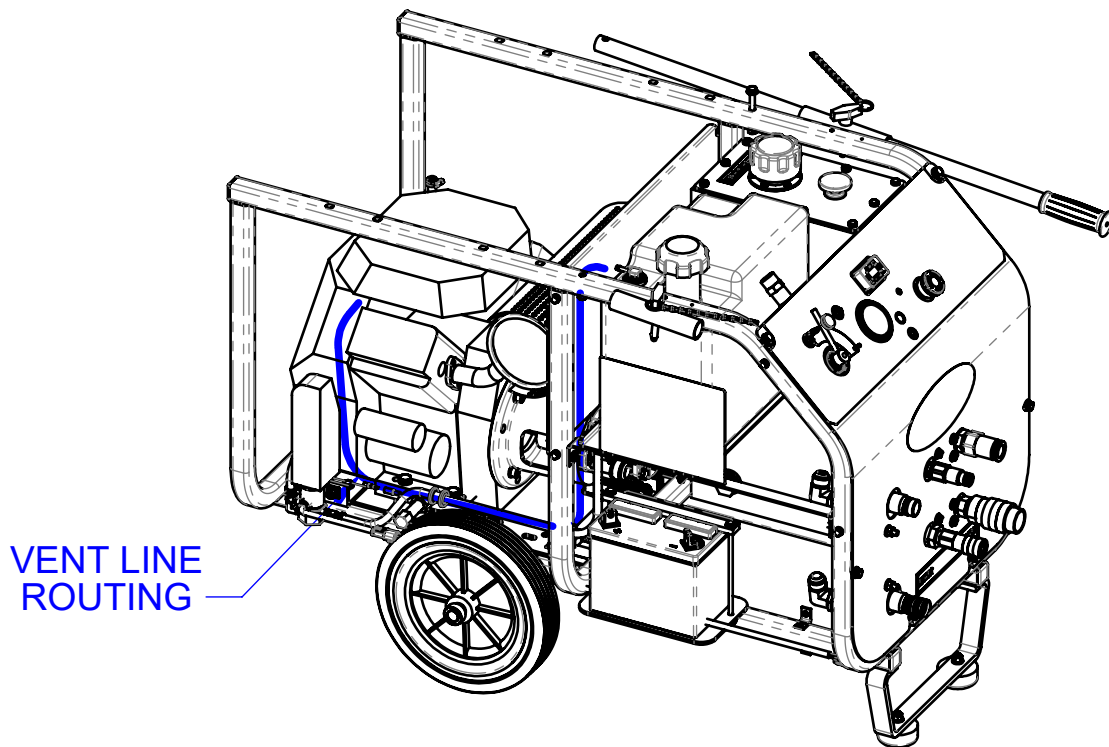

4600203 GAS TANK ASSEMBLY

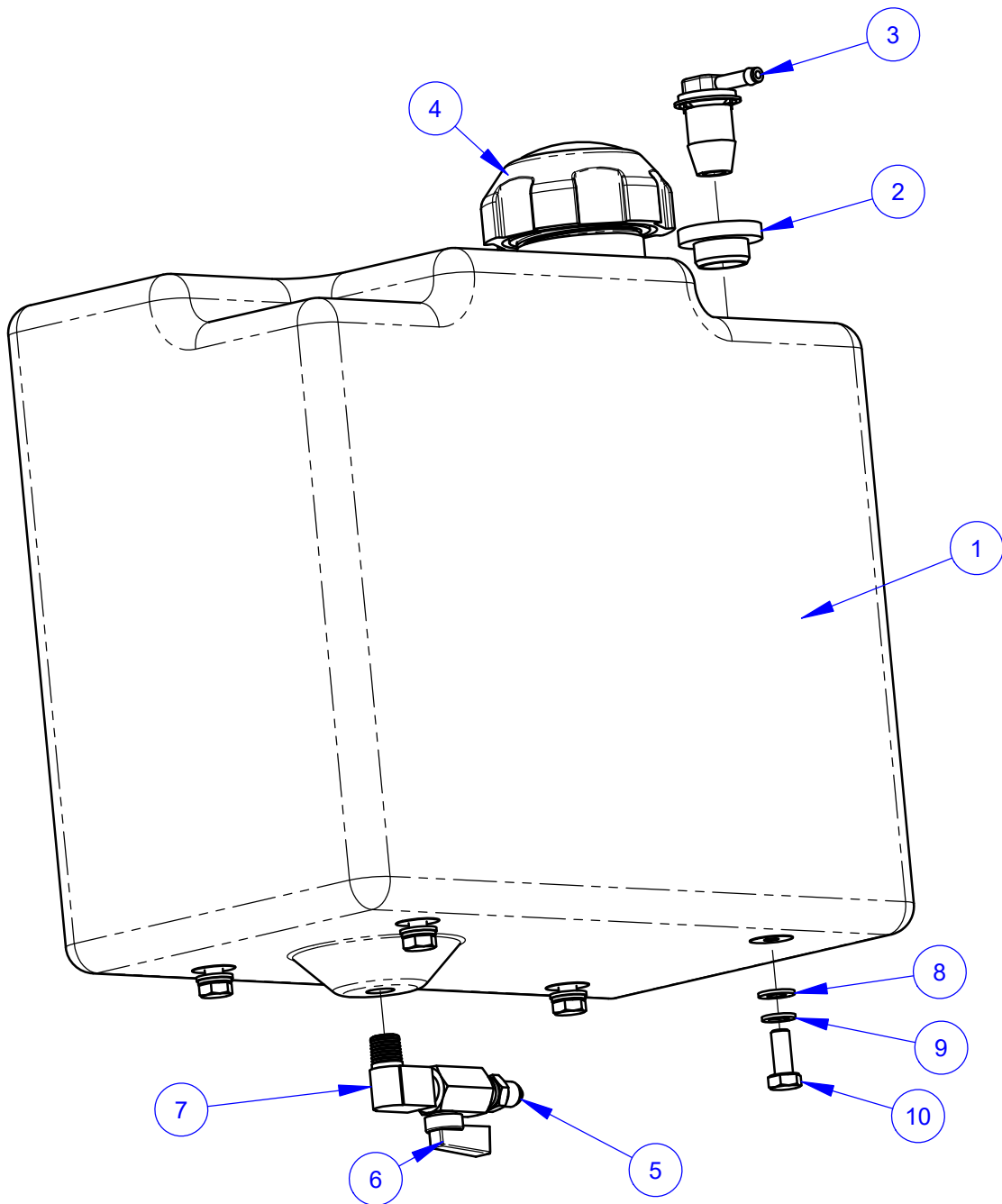

ITEM	PART NO.	QTY.	DESCRIPTION
1	6010869	1	Fuel Tank, 4.4 Gallon
2	2506716	1	Grommet
3	2502484	1	Roll Over Vent, 1/4" Hose Barb
4	2503294	1	Fuel Tank Cap, W/Gage
5	3200418	1	Adapter, 1/4" M. Pipe to 1/4" M. JIC
6	3200108	1	Ball Valve, 1/4" NPT
7	3200012	1	Street Elbow, 1/4" NPT
8	2901336	4	Flat Washer, M8
9	2900763	4	Lock Washer, M8 Split
10	2900329	4	Cap Screw, Hex Hd., M8-1.25 x 20mm

Fuel Solenoid with Connector, #4646241

DISCHARGE SIDE
TO FUEL FILTER

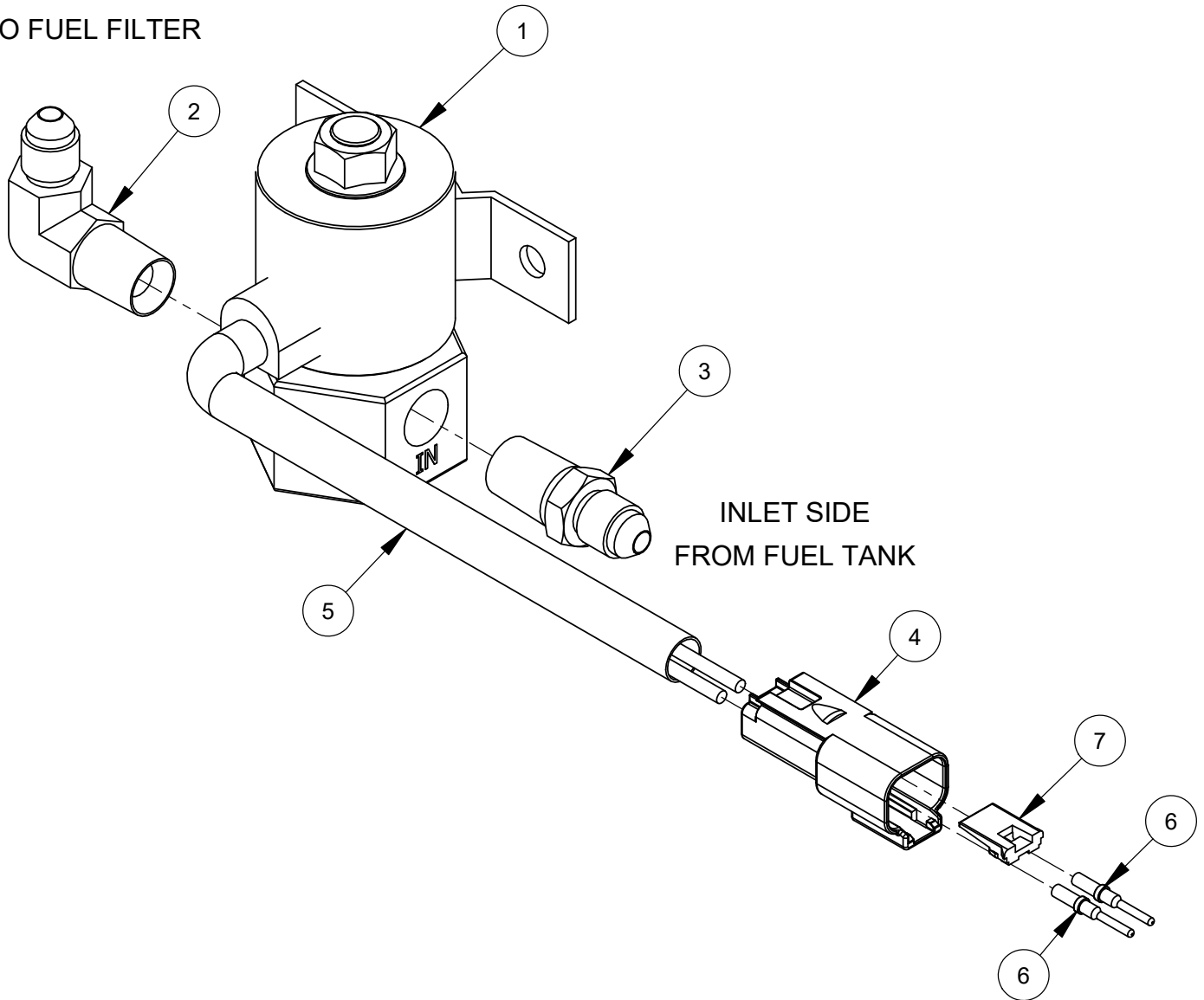

ITEM	PART NO.	QTY.	DESCRIPTION
1	4600174	1	Fuel Solenoid Valve
2	3200057	1	Elbow, 1/4" M. Pipe to 1/4" M. JIC
3	3200418	1	Adapter, 1/4" M. Pipe to 1/4" M. JIC
4	2808060	1	Deutsch Receptacle 2 Way
5	2801486	1	Split Loom, 3/8" OD
6	2704667	2	Pin Terminal 16-20 AWG
7	2801057	1	Wedge, Receptacle 2 Way

4646244 CP22XL Solenoid Valve Assembly

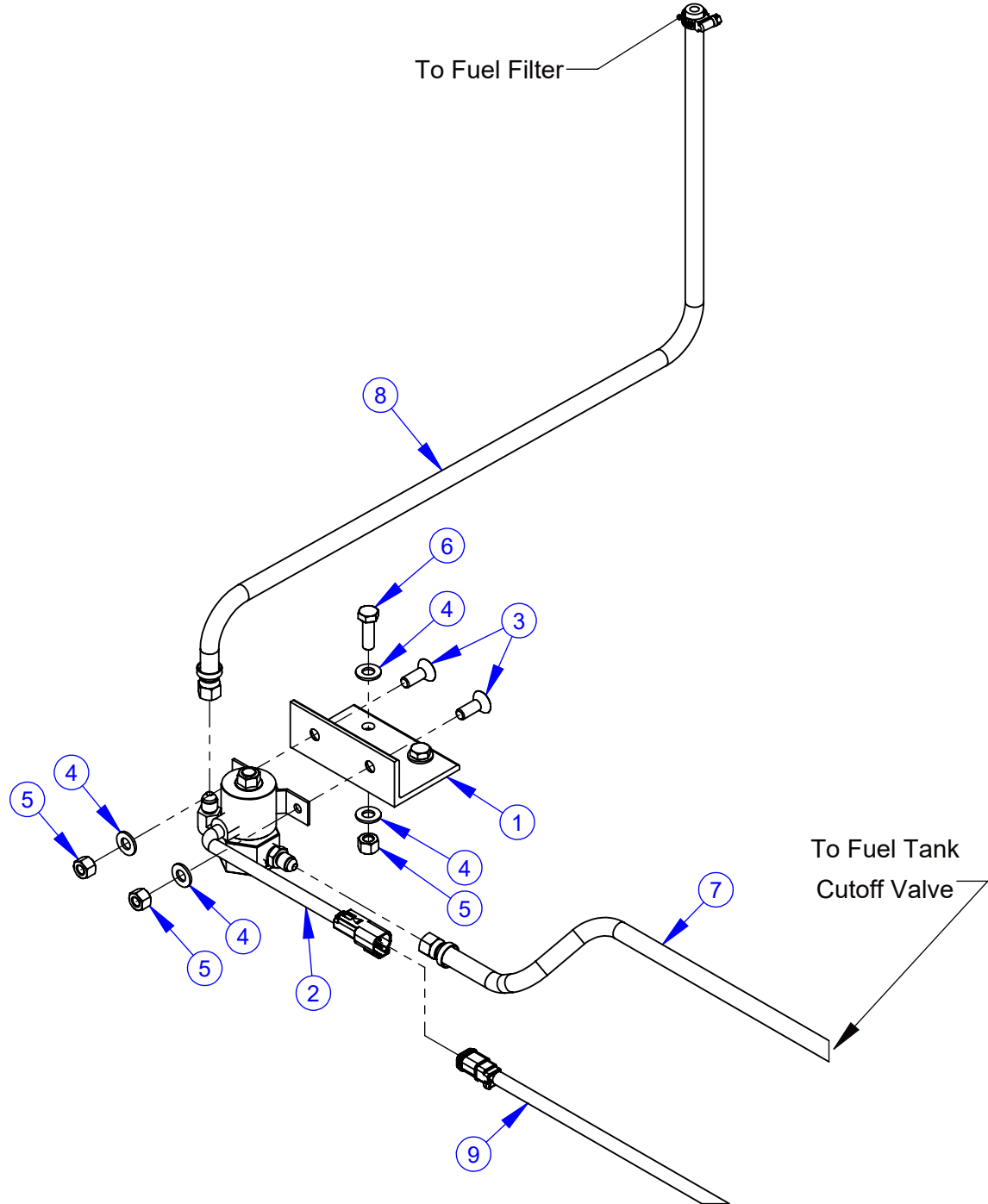

ITEM	PART NO.	QTY.	DESCRIPTION
1	4646238	1	Solenoid Mounting Bracket
2	4646241	1	Fuel Solenoid with Connector
3	2900612	2	Cap Screw, Flat Hd., 5/16-18 x 7/8"
4	2900022	6	Flat Washer, 5/16" SAE
5	2900039	4	Lock Nut, 5/16-18 Nylon
6	2900138	2	Cap Screw, Hex Hd., 5/16-18 x 1"
7	4646239	1	Fuel Hose Assembly, 1/4" x 41-1/2"
8	4646243	1	Fuel Filter Hose Assembly, 1/4" x 30"
9	4646233	1	Fuel Solenoid Harness

4646190 CP22XL ELECTRIC SCHEMATIC

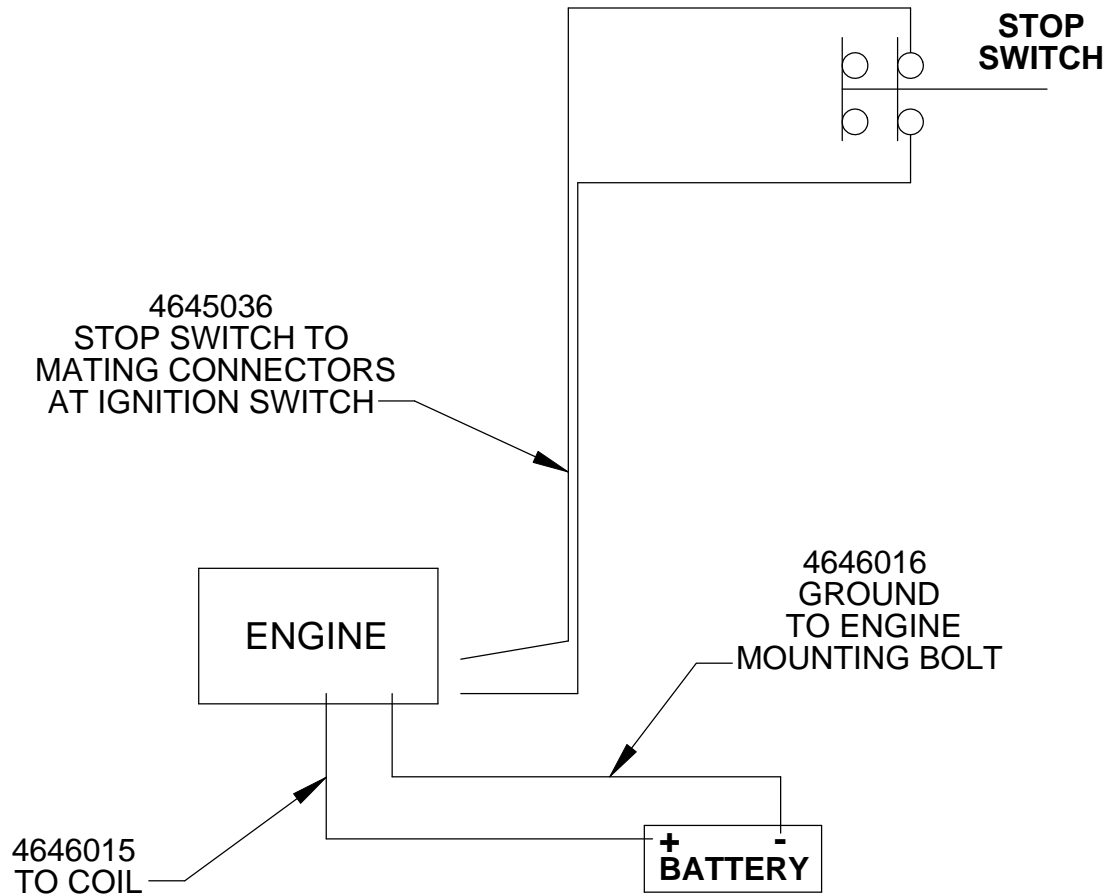

FOR EASE OF ASSEMBLY, ATTACH WIRES TO STOP SWITCH
BEFORE INSTALLING IN PANEL.

4646173 HYDRAULIC TANK ASSEMBLY

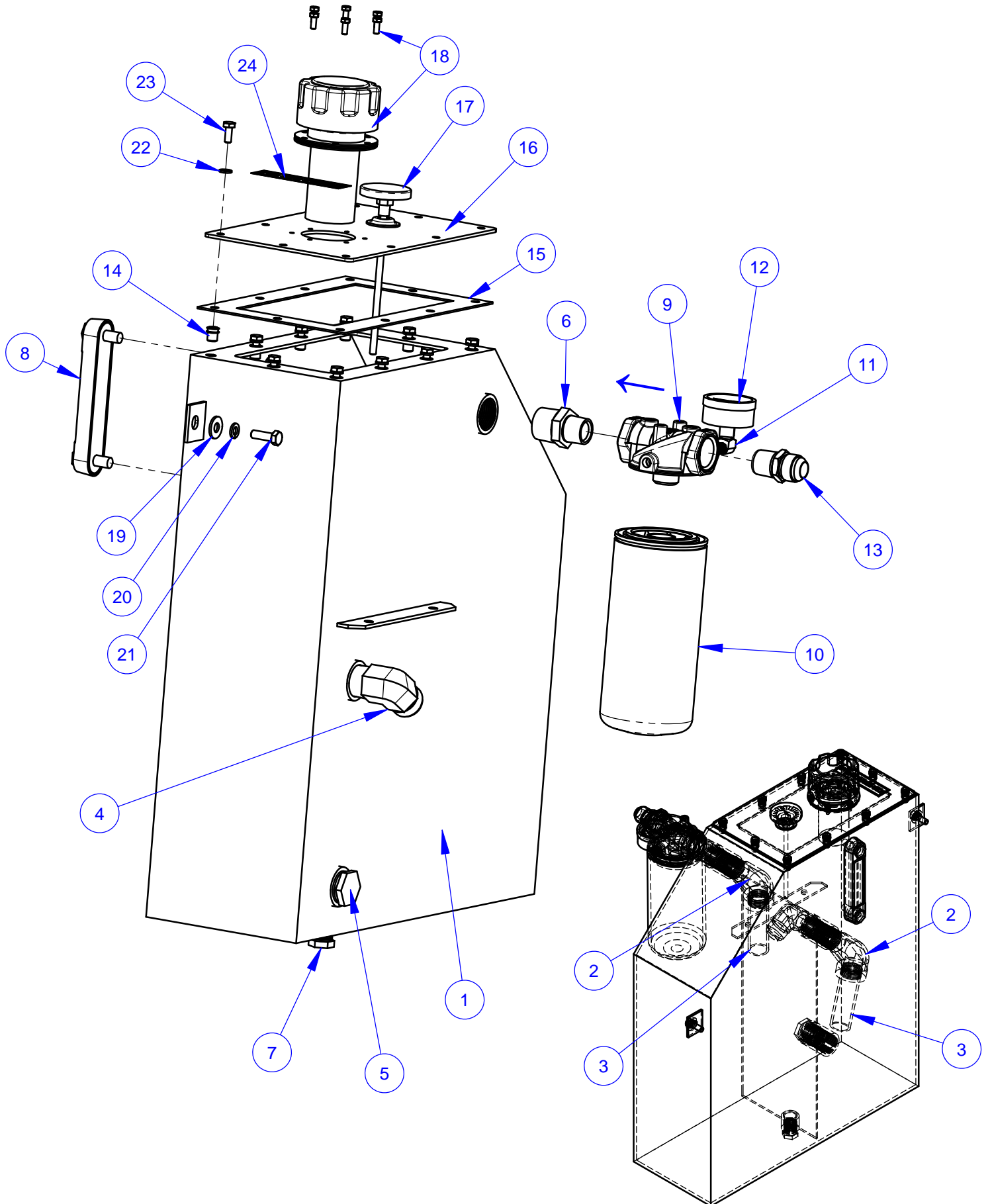

4646173 HYDRAULIC TANK ASSEMBLY

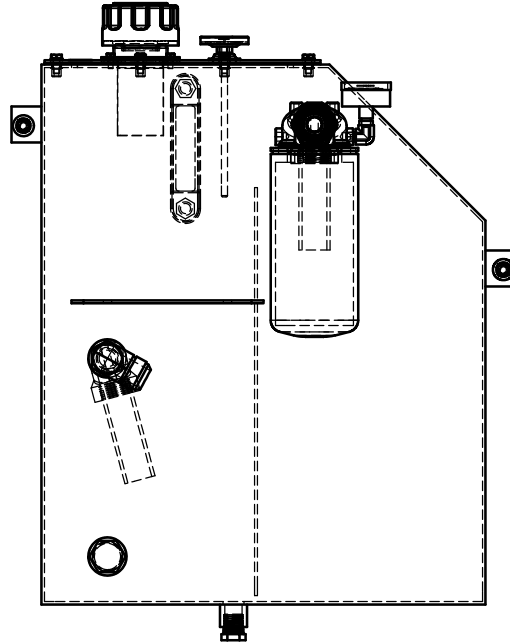

ITEM	PART NO.	QTY.	DESCRIPTION
1	4640120	1	Hydraulic Tank Weldment
2	3200409	2	Street Elbow, 1" NPT
3	3200427	2	Nipple, 1" NPT x 4", Schedule 40
4	3200289	1	Elbow, 1" M. Pipe to 1" M. JIC
5	3200288	1	Plug, 1" NPT
6	3200431	1	Nipple, 1"MPT - 3/4" MPT
7	3200160	1	Plug, 1/2-14 NPT
8	2400166	1	Sight Gauge, Liquid Level
9	2703290	1	Filter Head, 3/4" NPT
10	3201175	1	Hydraulic Filter Element
11	3200156	1	Street Elbow, 1/8" NPT
12	3200502	1	Gauge, Hydraulic Pressure
13	3200097	1	Adapter, 3/4" M. JIC to 3/4" M. Pipe
14	2900441	10	Rivet Nut, 1/4-20 Round
15	4646083	1	Gasket, Hyd Tank
16	4640121	1	Cover, Hydraulic Tank
17	2800459	1	Thermometer, 2", 0 - 200 F
18	2401305	1	Filler/Breather Cap (Top Mount)
	2900339	6	Cap Screw, Hex Hd., M5 x 12mm
19	2900567	2	Flat Washer, 5/16" USS
20	2900031	2	Lock Washer, 5/16" Split
21	2900138	2	Cap Screw, Hex Hd., 5/16-18 x 1"
22	2900024	10	Lock Washer, 1/4" Split
23	2900023	10	Cap Screw, Hex Hd., 1/4-20 x 5/8"
24	1800535	1	Decal, "Hydraulic Fluid Only"

4646189 CP22XL PANEL ASSEMBLY

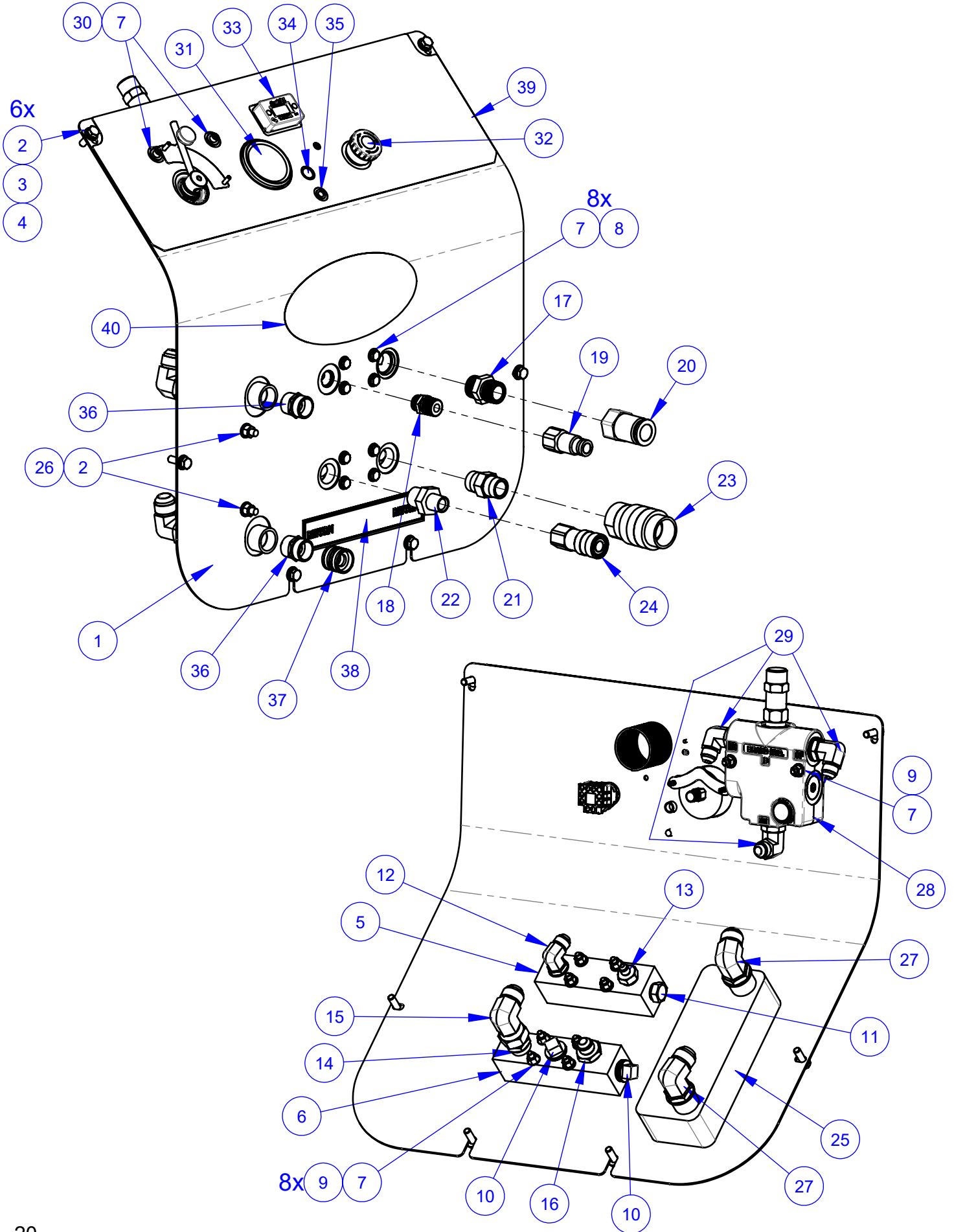

4646189 CP22 XL PANEL ASSEMBLY

ITEM	PART NO.	QTY.	DESCRIPTION
1	4646141	1	Instrument Panel
2	2900022	8	Flat Washer, 5/16" SAE
3	2900031	6	Lock Washer, 5/16" Split
4	2900138	6	Cap Screw, Hex Hd., 5/16-18 x 1"
5	4646102	1	Manifold, SAE O-Ring
6	4646101	1	Manifold, 3/4 NPT
7	2900009	20	Flat Washer, 1/4" SAE
8	2901001	8	Cap Screw, Hex Hd., 1/4-20 x 2-1/2"
9	2900010	10	Lock Nut, 1/4-20 Nylon
10	3200479	2	Plug, 3/4" NPT Square Head
11	3201434	1	Plug, 1/2" SAE O-Ring Hex
12	3200285	1	Elbow, 1/2" O-Ring to 1/2" M. JIC
13	3201291	1	Adapter, 1/2"M.O-Ring to 1/4" MJIC
14	3200097	1	Adapter, 3/4" M. JIC to 3/4" M. Pipe
15	3200417	1	Elbow, 3/4" F. JIC to 3/4" M. JIC
16	3201522	1	Adapter, 3/4" M. Pipe to 1/2" M. JIC
17	3200330	1	Adapter, 3/4" M. Pipe to 3/4" O-Ring
18	3200371	1	Adaptor, 1/2" MPT to 1/2" O-Ring
19	3200105	1	Nipple, 1/2" Q.D.
20	3200101	1	Nipple, 3/4" Quick Disconnect
21	3200137	1	Hex Nipple, 3/4" NPT
22	3200383	1	Nipple, Hex, 3/4" MPT TO 1/2" MPT
23	3200100	1	Coupler, 3/4" Quick Disconnect
24	3200104	1	Coupler, 1/2" Q.D.
25	2400256	1	Heat Exchanger
26	2900303	2	Lock Nut, M8-1.25 Nylon Insert
27	3200400	2	Elbow, 3/4" O-Ring to 3/4" Male JIC
28	3201654	1	Valve, Flow Control
29	3200366	3	Elbow, 5/8" O-Ring to 1/2" Male JIC, 90 Deg.
30	2900245	2	Cap Screw, Soc. Hd., 1/4-20 x 2-5/8"
31	3200250	1	Gauge, Hydraulic, 3000 PSI
32	2800893	1	E-Stop Switch, DPST
33	2801502	1	Tach/Hour Meter, W/#6 Screws
34	2500204	1	Plug, 1/2" Hole
35	2503749	1	Plug, 5/16" Hole (Tapered)
36	3201659	2	Fitting, 3/4" M. Pipe to 3/4" M. Garden
37	3200177	1	Fitting, 3/4" F. Garden Union Swivel
38	1800536	1	"Return" Decal
39	1802746	1	Decal, Control Panel
40	1802620	1	DP Oval Logo Decal

4400267 AIR TO OIL COOLER OPTION, CP22XL

(CANNOT BE USED IN CONJUNCTION WITH OPTIONAL TOOL TRAY #4400261)

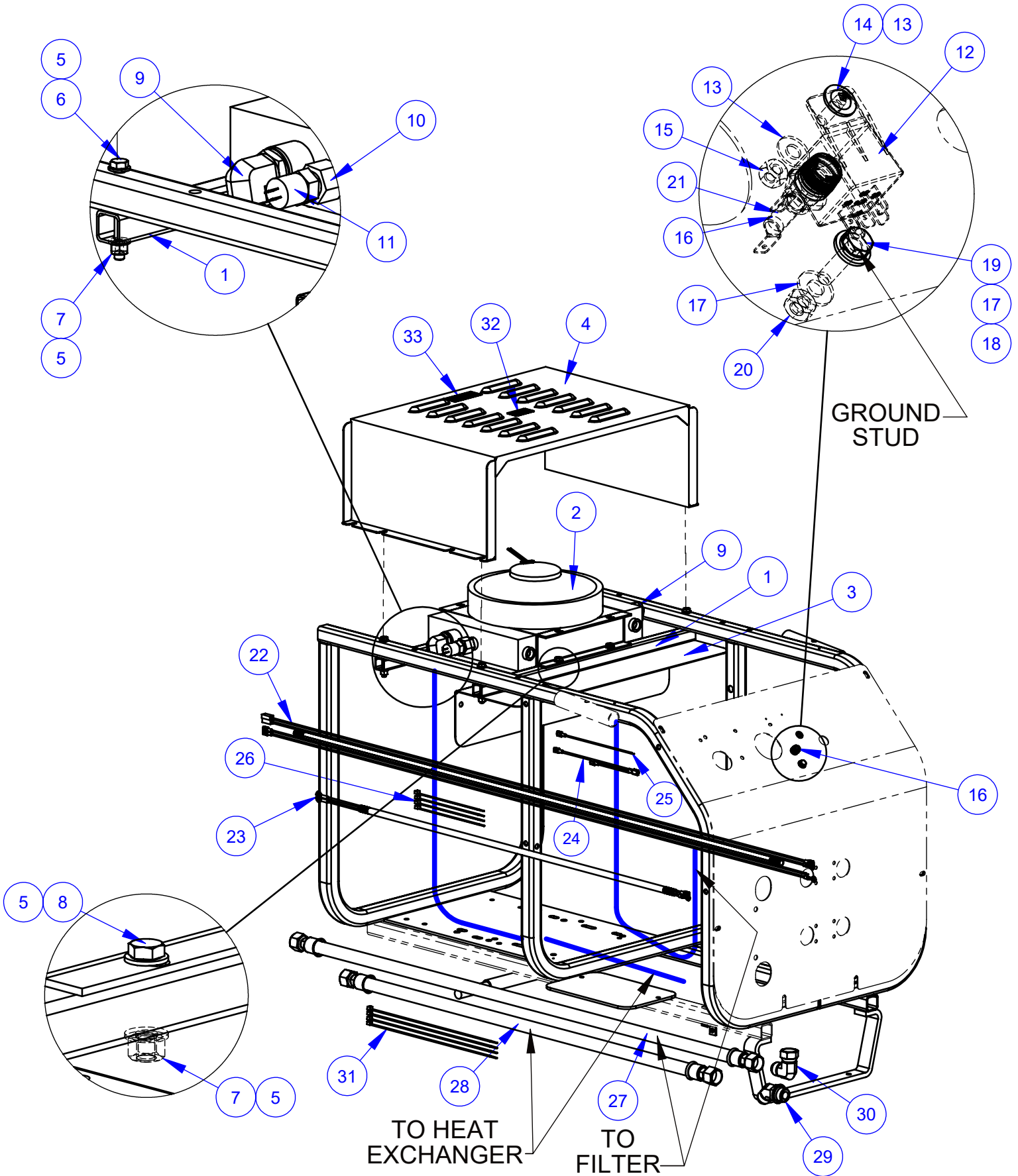

4400267 AIR TO OIL COOLER OPTION, CP22XL

(CANNOT BE USED IN CONJUNCTION WITH OPTIONAL TOOL TRAY #4400261)

- 1) ATTACH WIRES TO RELAY BEFORE BOLTING TO PANEL.
- 2) REMOVE ORIGINAL HOSE FROM HEAT EXCHANGER TO FILTER.
- 3) REPLACE ELBOW AT LOWER HEAT EXCHANGER PORT W/ 3200265.
- 4) ADD ELBOW 3200417 TO FILTER.
- 5) INSTALL LONGER HOSES.
- 6) SECURE WIRES AND HOSES WITH WIRE TIES.

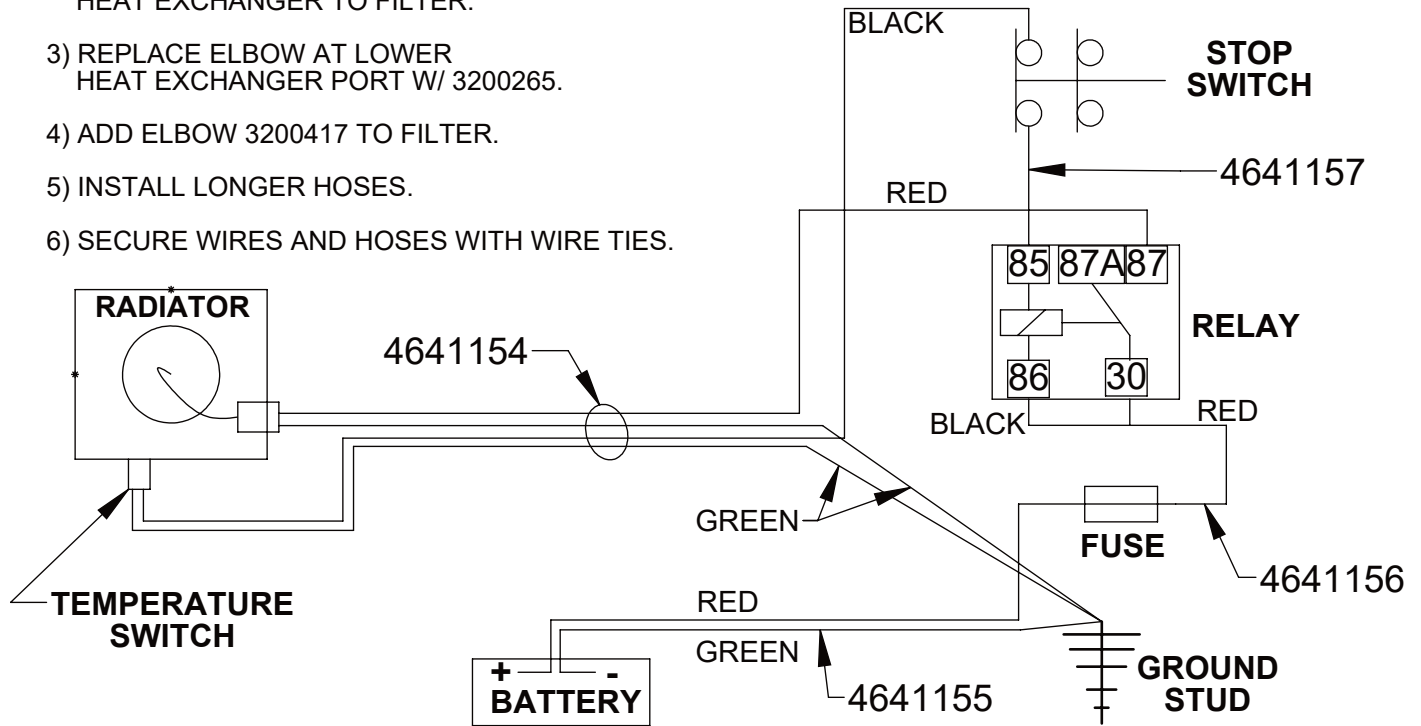

ITEM	PART NO.	QTY.	DESCRIPTION
1	4600083	2	Tube, 1" Sq. x 23-3/4"
2	2400318	1	Heat Exchanger, Air/Oil, 12 Volt
3	4641097	1	Heat Shield
4	4641159	1	Radiator Guard
5	2900022	16	Flat Washer, 5/16" SAE
6	2900248	4	Cap Screw, Hex Hd., 5/16-18 x 3"
7	2900039	8	Lock Nut, 5/16-18 Nylon
8	2900538	4	Cap Screw, Hex Hd., 5/16-18 x 1-3/4"
9	3200400	2	Elbow, 3/4" O-Ring to 3/4" Male JIC
10	3201012	1	1/2" O-ring - 1/2" FPT
11	2800697	1	Temperature Switch, 1/2 NPT
12	2800144	1	Relay, 50 Amp Mini
13	2900016	2	Flat Washer, #10 USS
14	2900159	1	Machine Screw, Rd. Hd., #10-24 x 5/8"
15	2900017	1	Lock Nut, #10-24 Nylon
16	2800481	1	Fuse Holder
17	2900009	2	Flat Washer, 1/4" SAE

ITEM	PART NO.	QTY.	DESCRIPTION
18	2900024	1	Lock Washer, 1/4" Split
19	2900008	1	Cap Screw, Hex Hd., 1/4-20 x 1"
20	2900125	1	Hex Nut, 1/4-20
21	2803014	1	Fuse, 15 Amp, Slo Blow
22	4641154	1	Wire Assy., 4 Wire
23	4641155	1	Wire Assy., Red & Grn, 14 Ga.
24	4641156	1	Wire Assy, Black & Red
25	4641157	1	Wire Assy., 20 Ga., Brn, 8-1/2"
26	2800068	4	Zip Tie, 7-1/2"
27	4645028	1	Hose Assembly, 3/4 x 51.4"
28	4646161	1	Hose Assembly, 3/4 x 41-3/8"
29	3200458	1	Elbow, 3/4" O-Ring to 3/4" M. JIC (45 deg)
30	3200417	1	Elbow, 3/4" F. JIC to 3/4" M. JIC
31	2800278	4	Zip Tie, 14"
32	1800537	1	Label, HOT
33	1801707	1	Decal, Caution, Fan

4400261 TOOL TRAY OPTION, GAS UNITS

(CANNOT BE USED IN CONJUNCTION WITH OPTIONAL AIR TO OIL COOLER)

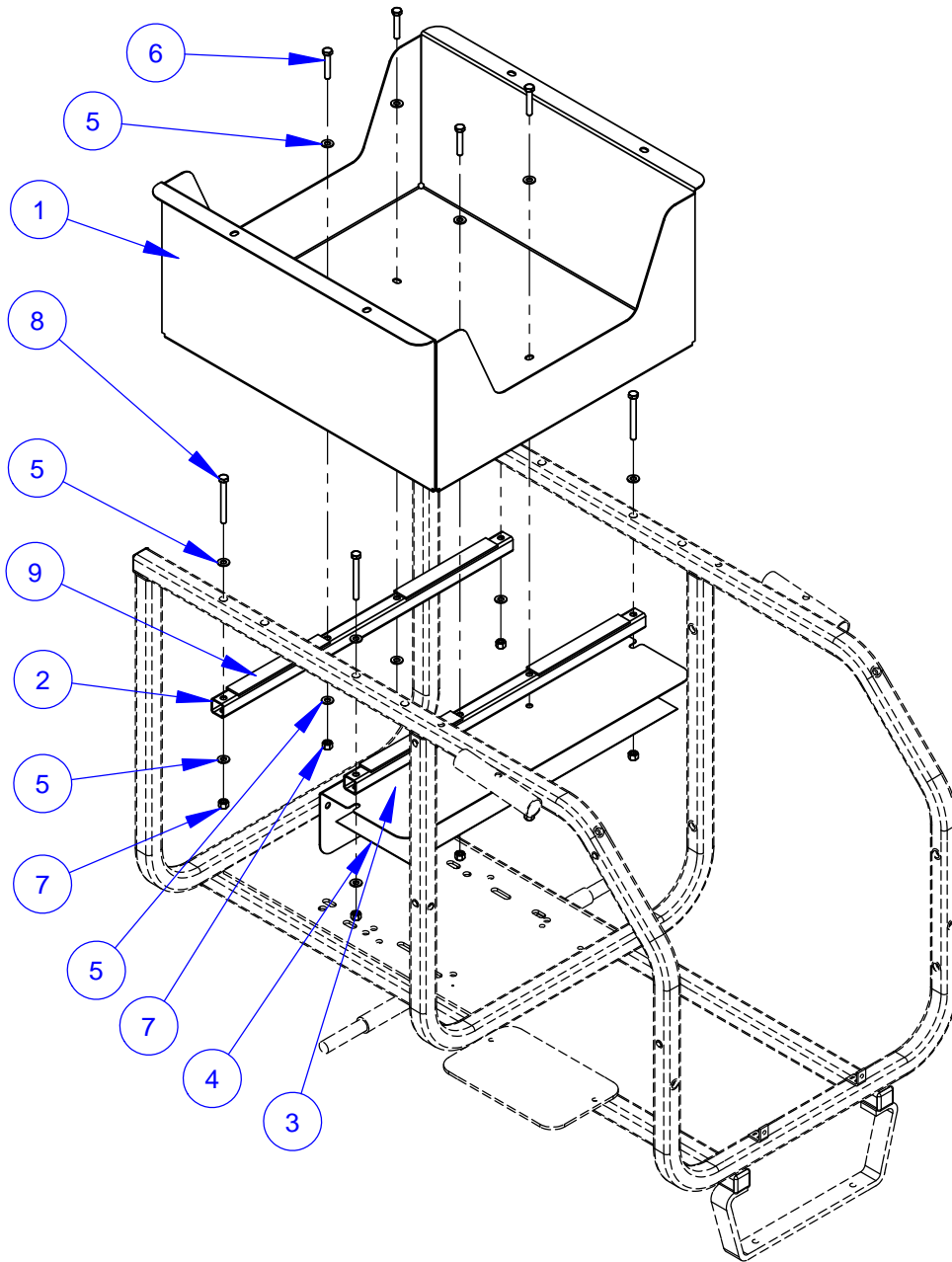

ITEM	PART NO.	QTY.	DESCRIPTION
1	4400207	1	Tool Tray
2	4600083	2	Tube, 1" Sq. x 23-3/4"
3	4641097	1	Heat Shield
4	4600167	1	Heat Shield Mat, 6x22"
5	2900022	16	Flat Washer, 5/16" SAE
6	2900538	4	Cap Screw, Hex Hd., 5/16-18 x 1-3/4"
7	2900039	8	Lock Nut, 5/16-18 Nylon
8	2900248	4	Cap Screw, Hex Hd., 5/16-18 x 3"
9	6048077	4	Rubber Strip

4641172 WHEEL UPGRADE KIT

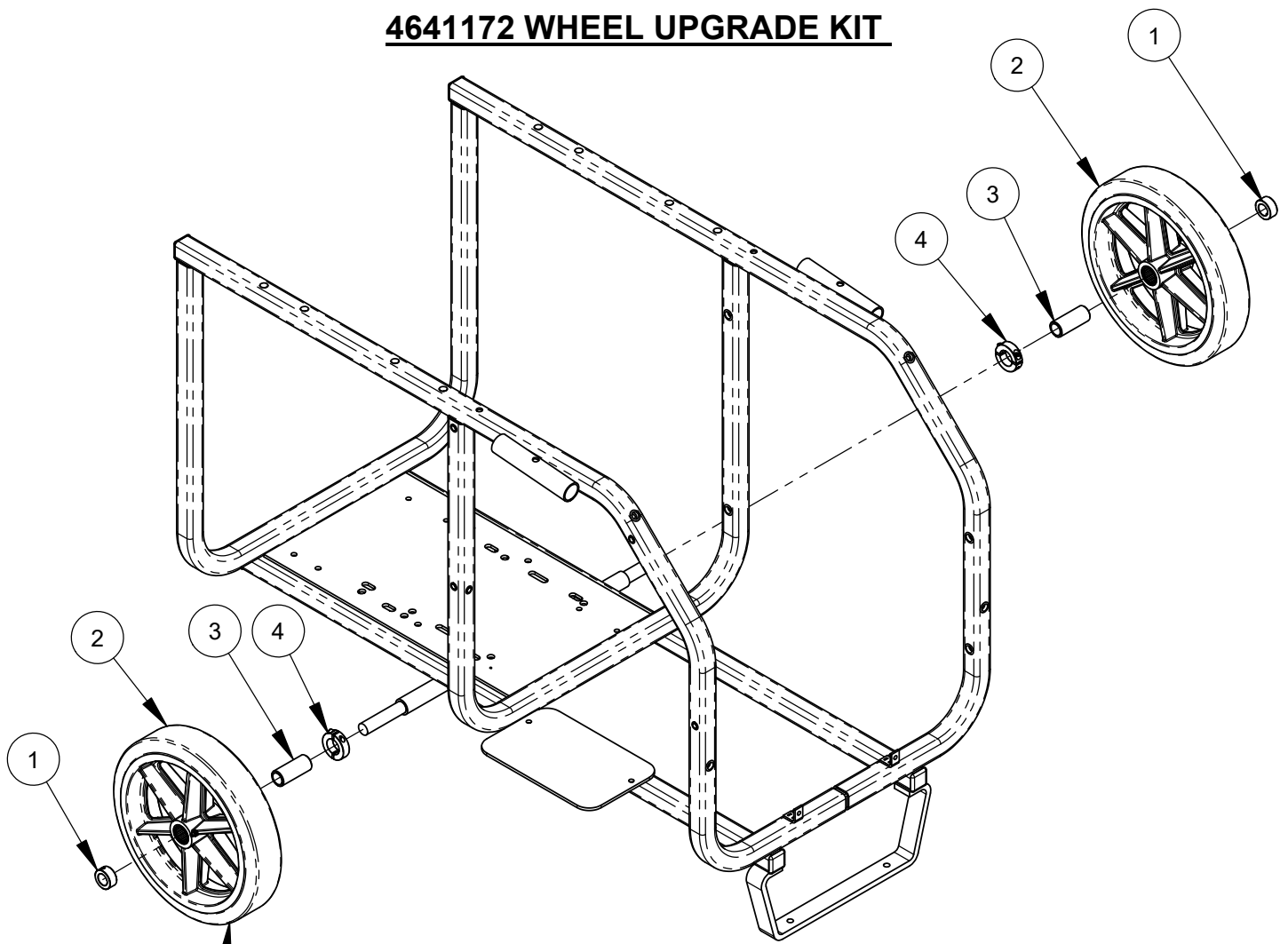

NOTE: WHEEL RESTS ON BOTH AXLE AND BUSHING (6041174)

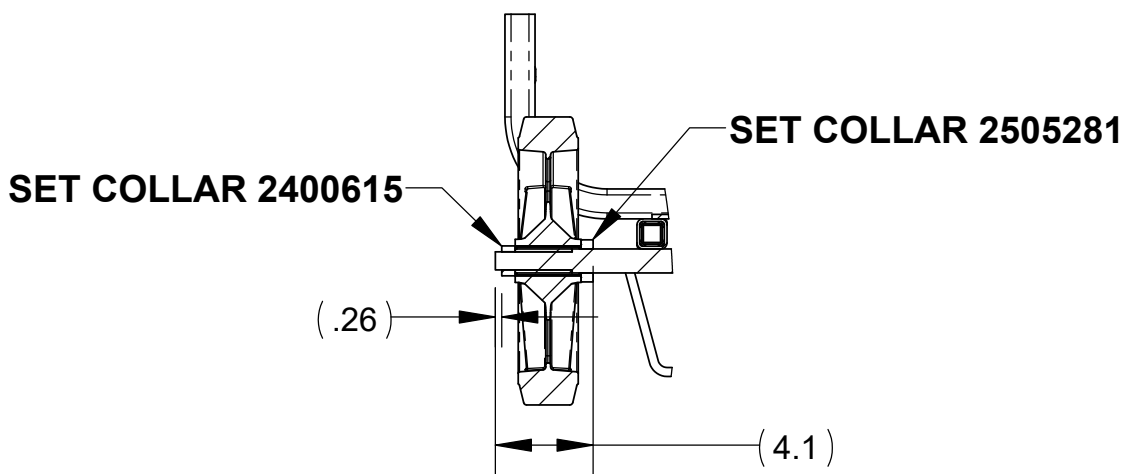

ITEM	PART NO.	QTY.	DESCRIPTION
1	2400615	2	Set Collar, 3/4"
2	2505179	2	Wheel 12" X 2-3/4" X 1"
3	6011774	2	Bushing, .75 x 1.00 x 2.38L
4	2505281	2	Set Collar, 1" ID (2 Piece)

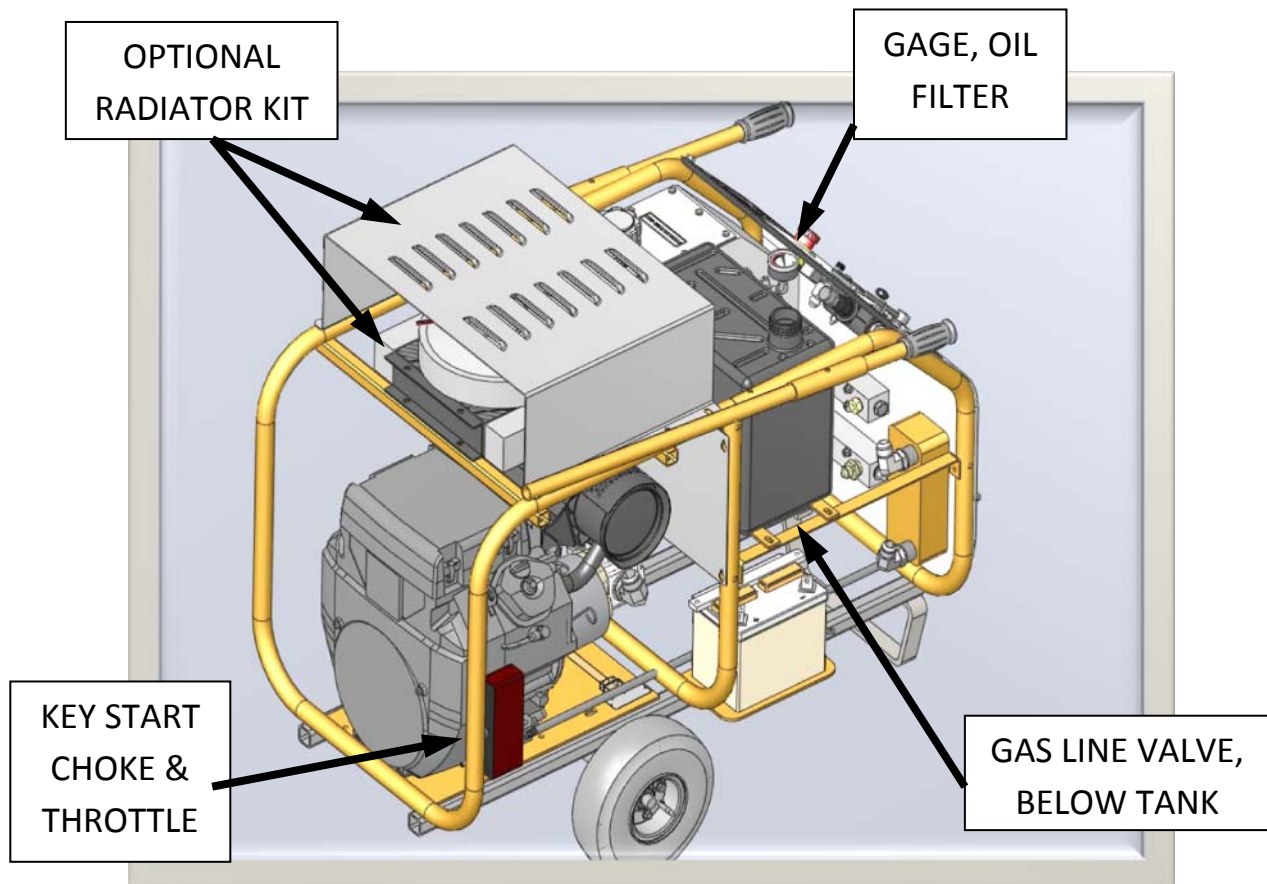
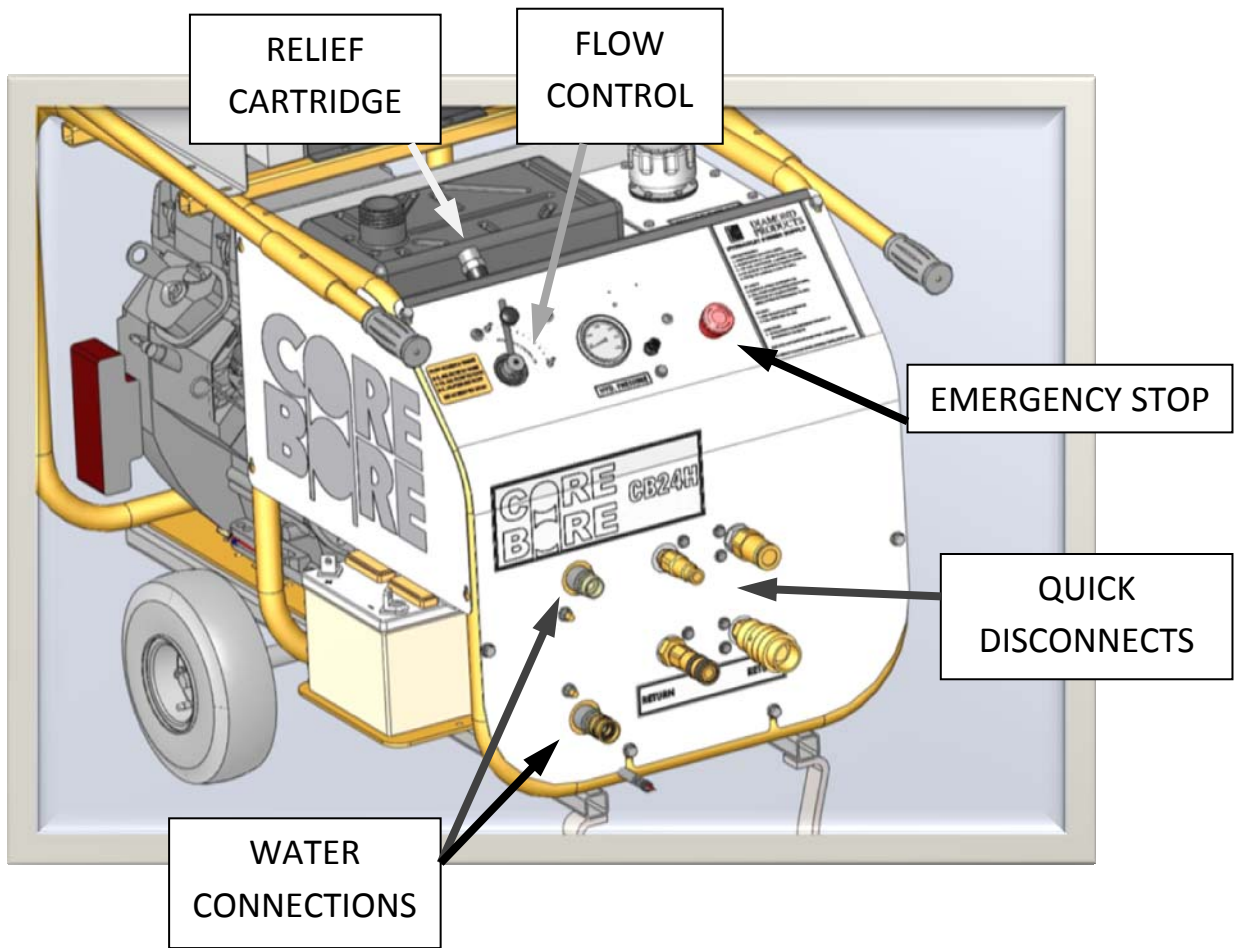

GENERAL SAFETY PRECAUTIONS

WARNING: Do not operate power unit without reading this entire manual and the engine operation manual first. Keep manuals with power unit at all times for reference.

This manual describes the operating procedures, care, maintenance, adjustments, and safety precautions for proper use of this machine. This equipment is intended for industrial applications by experienced operators. It is to be operated in conformance with applicable federal, state, and local codes or regulations pertaining to safety, air pollution, noise, etc.

Tool operators and maintenance personnel must always comply with the safety precautions given in this manual and on the stickers and tags attached to the equipment.

These safety precautions are given for your safety. Review them carefully before operating the tool and before performing general maintenance or repairs.

Supervising personnel should develop additional precautions relating to the specific work area and local safety regulations.

In addition to this manual, read and understand safety and operating instructions in the Engine Operation Manual furnished with the Power Unit in addition to this manual.

- Establish a training program for all operators to ensure safe operation.
- Do not operate the power unit unless thoroughly trained or under the supervision of an instructor.
- Do not inspect or clean the power unit while it is running.
- Always use hoses and fittings rated at a minimum 2600 p.s.i. (179 bar) with a 4 to 1 safety factor for pressure lines.
- Be sure all hose connections are tight.
- Make sure all hoses are connected for correct flow direction to and from the tool being used.
- Do not inspect hoses and fittings for leaks by using bare hands. "Pin-hole" pressure leaks can penetrate the skin.
- **Never operate the gas power unit in a closed space.** Inhalation of engine exhaust can be fatal.
- Do not operate a damaged or improperly adjusted power unit.
- Never wear loose clothing that can get entangled in the working parts of the power unit.
- Keep all parts of your body away from the working parts of the power unit.

- Always wear appropriate safety equipment such as goggles, ear protection, head protection and safety shoes. Certain tools used in conjunction with the power unit may require other safety equipment such as breathing filters.
- Keep clear of hot engine exhaust.
- Do not add fuel to the power unit while the power unit is still running or is still hot.
- Do not operate the power unit if a gasoline odor is present.
- Do not use flammable solvents around the power unit engine.
- Do not operate the power unit within 3 ft. (1 meter) of buildings or flammable objects.
- Allow the engine to cool before storing the unit in an enclosed area.
- To avoid personal injury or equipment damage, all tool repair, maintenance and service must only be performed by authorized and properly trained personnel.

IMPORTANT: The red stop button at the front panel will immediately stop the engine. Hydraulic pressure and flow will go to zero. This button must be in the out position to start the unit.

DANGER: Improper use or alteration of this equipment may be extremely hazardous.

SAFETY SYMBOLS

Safety symbols are used to emphasize actions which could result in a life-threatening situation, bodily injury, or damage to equipment.

Always observe safety symbols. They are included for your safety and for the protection of the tool.

! DANGER !

This safety symbol may appear on the tool. It is used to alert the operator of an action that could place him/her or others in a life threatening situation.

!WARNING: !

This safety symbol appears in these instructions to identify an action that could cause bodily injury to the operator or to other threatening situation.

! IMPORTANT!

This safety symbol appears in these instructions to identify an action or condition that could result in damage to the tool or other equipment.

DESCRIPTION AND SPECIFICATIONS

Pump: Gear, pump rotation is clockwise (motor is CCW).

Maximum GPM: 14.1 GPM (53.2L/M) at no load. Flow will decrease as pressure increases.

Hydraulic Fluid Tank Capacity: 11 gallons (41.6Liters)

Hose Couplings: Bruning quick disconnect, 3/4 inch & 1/2 inch

Relief Pressure: Factory set at 2600 PSI /179.3 Bar (at valve outlet port). Adjustable to 750 PSI, A higher relief setting will stall the engine.

Engine: Honda 21.4 HP (16.0 KW) Net @ 3600RPM, Air-cooled, No load RPM set to 3850.

Fuel tank: 4.4 Gal (16.6L).

This unit is compatible with most hydraulically driven sawing and drilling components. The system may not be compatible with components of some manufacturers.

The power unit was inspected and operated before shipment and should not require any additional adjustments prior to its initial use.

Hydraulic Fluid: The reservoir of the hydraulic power unit must be full prior to start-up. The use of high quality petroleum based hydraulic oil with the following properties is recommended:

- Anti-wear
- Low foaming
- Rust and oxidation inhibitors
- Wide temperature range
- Fluid viscosity: 8-1000 Centistokes (52-4600 SUS). The unit is shipped with an ISO 46 Viscosity grade (8Cs/52SUS @ 212F/100C and 46Cs/210SUS @ 104F/40C).

The oil must be kept free of contamination to avoid damage to system components. The strainer in the fill cap must always be in place when adding oil. Quick disconnects must be cleaned before connections are made.

Control Valve: The pressure compensated flow control valve on this unit allows full flow control while the gas engine remains at its most efficient wide-open throttle. This allows a higher operating pressure at all flows. Flow settings are: 0-2, all flow routed to tank; 2-8, adjustable range, 8-10 full flow.

Relief pressure can be adjusted by removing the cap at the top of the main

control and using an Allen wrench to adjust the relief cartridge. The relief can be set as low as 750 psi; do not exceed 2600 psi. To adjust, the flow control must be set at 10 and no tool should be attached. This will force all flow over relief. Securely replace the cap as oil seepage will occur through the relief cartridge. The relief is factory set at 2600 psi and should rarely need adjustment.

Hydraulic Oil Cooler and Radiator: The power unit is equipped with a brazed plate style oil cooler. Water should be passed through the cooler before being used for dust control or blade & bit cooling. Some tools will automatically shut off water flow when not actively cutting, drilling, etc. This may result in higher oil temperatures if the power unit continues to run for long periods without cooling water. The optional radiator fan will come on automatically when the oil temperature reaches ~120F. (49C.) and continue to run until the temperature switch cools, even if the engine is shut off. The fan *will* stop whenever the emergency stop switch is used.

IMPORTANT: If there is a risk of frost the water must be drained from the cooler to prevent damage by freezing.

HOSES: Large diameters and short lengths are preferred and offer the highest system efficiency. If one is operating 50 ft (15.2M) from the power source, there is also a 50 ft (15.2M) return for a 100 ft (35.5M) total hose length. With 12 GPM and oil at 100 deg. F (37.8C), this could result in a 300 psi (20.6 Bar) pressure loss with ½” hose and a 100 psi (6.9 Bar) loss with 5/8” hose. Pressure loss will change dramatically with oil temperature.

OPERATING INSTRUCTIONS

Operator Responsibilities

It is the operator’s responsibility to use this unit and any attached tools under safe working conditions and to follow proper safety procedures for themselves, co-workers, observers, and the public at large. The operator must be aware of the machine’s capabilities and limitations and follow the safety precautions in each section of this manual. Periodic maintenance is required, in accordance with the instructions herein, to promote safe and reliable operations.

WARNING: Keep bystanders out of the immediate work area.

Wear approved:

- Safety glasses
- Ear protection
- Hard hat
- Gloves
- Safety shoes
- Any other protective equipment required for compliance with standard safety practices or federal, state, and local codes and regulations

Hose Connections: It is best to connect the hoses to the unit before starting as even very low residual pressure can make hose installation more difficult. Push couplings together until you hear it click. Turn locking ring of coupling to the secured position.

Gas Engine: Make sure that the engine crankcase is filled with oil to the proper level! Refer to your engine manual for oil checking and changing procedures, along with oil specifications, etc.

IMPORTANT: Operating the engine without oil will ruin the engine.

Fuel: Use regular grade unleaded gasoline to fuel the engine. Premium grade may be used if necessary. Fill the tank when the engine is off and has been allowed to cool. Care should be taken to prevent spilling fuel. **Do not overfill the fuel tank.** Always leave enough space for expansion due to environmental heating.

WARNING: In the event of fuel spillage, do not start the engine or operate any nearby electrical component until the spilled fuel has been removed.

Starting Procedure:

- Set the flow control valve to zero.
- Open the fuel shut off valve below the gas tank.
- Be certain the emergency off switch has been pulled out.
- Set throttle at about 1/3, set choke if necessary (cold engine). Turn key to start and release. Refer to engine manual for details of control functions.
- Let engine warm and gradually open the choke and set the throttle to maximum.

DANGER: Exhaust from the gas engine contains carbon monoxide, a poisonous, odorless, invisible gas, which can cause serious illness or death. Do not operate the gas engine where ventilation is restricted. Open windows and doors may not be sufficient to prevent this hazard.

Heating Cold Oil: Forcing the oil over relief will quickly increase the oil temperature. With no tool connected to the unit, move the valve setting toward 10. This will force an increasing percentage of oil over relief. Heat cold oil to room temperature or ~100F/38C maximum. Cold oil greatly increases pressure loss in hoses and fittings and may affect tool operation.

Maintaining Oil Temperature: With an ample water supply, it is unlikely overheating will be an issue except in the most extreme ambient temperatures. To force high oil temperatures down, run the unit with the flow control set to zero. This unloads the unit yet circulates oil through the cooling system. The rate of cooling will depend on the ambient temperature and how much water is being passed through the cooler.

Some control valves at the external tool may create backpressure and heat even when off. It is best to set the flow control to zero or shut the power unit down to avoid heating and conserve energy.

IMPORTANT: Monitor the thermometer at the top of the hydraulic tank. Maximum recommended oil temperature is 180 degrees Fahrenheit (82 deg C).

Shutting Down:

- Shift the flow control valve to zero to unload the system.
- Throttle the engine back to a low RPM.
- Turn the key to the off position.

IMPORTANT: The red emergency stop button at the front panel will immediately stop the engine and radiator fan (if equipped). Hydraulic pressure and flow will go to zero. This button must be in the out position to start the engine.

OPERATING DRIVEN EQUIPMENT

The operator must know the hydraulic requirements and limitations of the driven equipment and the appropriate adjustments must be made on the controls. The introduction of other control devices may cause system heating or may render the system inoperative.

IMPORTANT: This power unit is equipped with a positive displacement gear pump. All tools must be equipped with a control valve that allows flow directly to return ports when not in use. Blocking oil flow or abruptly disconnecting the tool can send flow over relief and potentially overheat the system.

Instructions supplied with the driven equipment must be followed to ensure correct connection and operation of each individual piece of equipment. Equipment supplied by Diamond Products will be capable of being connected correctly and will be compatible with this power unit, providing neither has been modified from original factory configuration. With equipment of other manufacturers, it will be necessary to determine the following:

- Correct direction of flow through the equipment.
- Correct pressure and flow required by the equipment.
- Compatibility of any valves or circuitry and quick disconnects. Some hand-held equipment uses a trigger control, which is operated frequently. These valves must be of the open center type for correct operation.

IMPORTANT: The quick disconnects must be clean when connecting hoses and devices. Dirty connections may result in contamination and premature failure of system or tool components.

MAINTENANCE INSTRUCTIONS

- Oil Filter: change the filter when indicated by the gage at the filter.
- Oil Change: establishing an oil analysis program is the preferred method of determining oil condition and when to change it. If the oil is kept clean, dry, and operated at moderate temperatures, it can last for several years. With no analysis program an oil change every 200 hours is recommended. See the section Hydraulic Fluid for specifications. A ½” pipe thread oil drain port is at the bottom of the hydraulic tank.
- Gas Engine Oil: Change engine oil and filter and perform other routine maintenance as recommended in the engine operation manual.
- Inspect hoses, couplings, and fittings daily for leaks, tighten as required. Clean quick disconnects frequently. Replace any leaking or defective components immediately.
- Check hydraulic oil level daily. Fill tank to upper end of sight tube with unit off.
- Grease the wheel bearings annually.

TROUBLESHOOTING

PROBLEM	POSSIBLE SOLUTIONS
Gas engine will not start.	1) Pull out emergency stop button. 2) Open gas line valve below gas tank. 3) Dead battery? 4) Low engine oil?
Low oil flow.	Check gas engine RPM at tachometer on front panel. Adjust governor to 3850 RPM if required. See engine manual.
System builds high pressure with flow control valve set to zero.	Contamination may have plugged an orifice in the CF port of the flow valve. Detach the valve from the front panel and remove the fitting from the CF port. A .015” orifice should be visible at the bottom of the port. Push a fine wire through the orifice and re-install.

Keep this manual and the engine manual readily available at all times for reference.

CP POWER PACK FLOW AND PRESSURE RATING

CP POWER PACK MODEL	MAXIMUM <u>NO</u> <u>LOAD</u> FLOW GPM/LPM	RELIEF SETTING PSI/BAR
15 Electric	12.75 / 48.2	2100 / 145
18 Briggs Vanguard	11.6 / 43.9	2850 / 196.5
20 Electric	14.9 / 56.4	2400 / 165.5
21 Honda	14.1 / 53.2	2600 / 179.3
30 Electric	20.4 / 77.2	2300 / 158.6
35 Briggs Vanguard	17.2 / 65.1	3000 / 206.9

Maximum no load flow is based on pump and motor manufacturer's specifications for pump displacement and no load RPM. Relief is set to insure gas engines cannot reach their stall torque and electric motors will not exceed the recommended current limit.

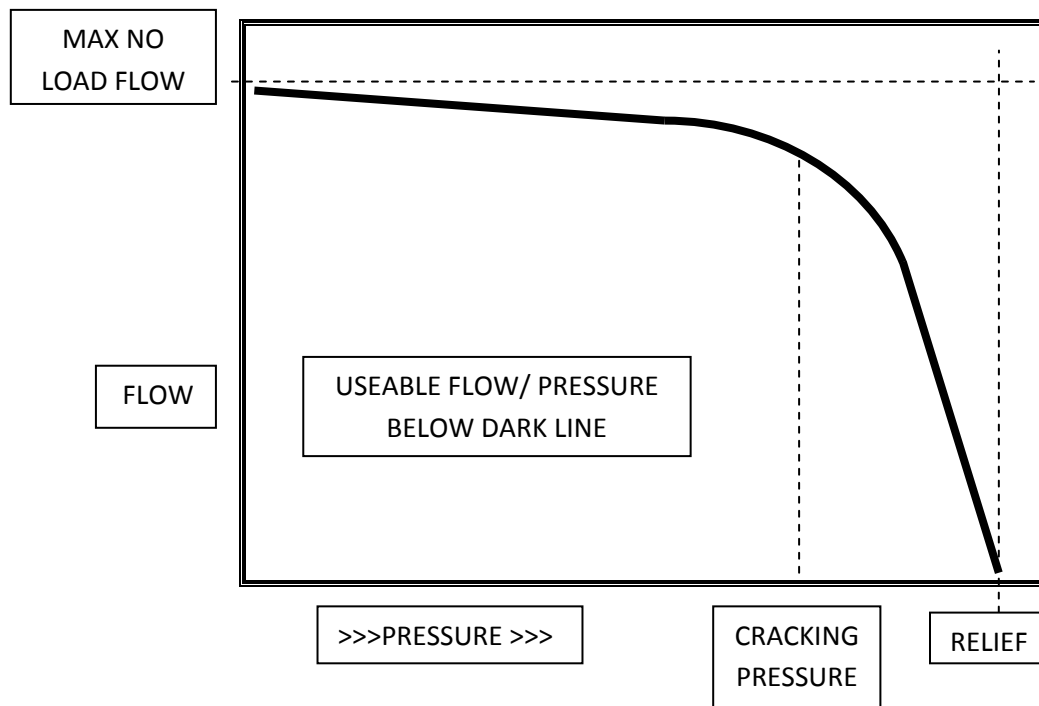

Flow decreases as engine/motor RPM drops under load. Relief valves begin to open and shunt flow to tank at 75-80% of the relief setting (cracking pressure). This further reduces flow to the tool. At relief, all flow is directed to tank.

Issued August 2011

EQUIPMENT AND PARTS WARRANTY

Diamond Products warrants all equipment manufactured by it against defects in workmanship or materials for a period of one (1) year from the date of shipment to Customer.

The responsibility of Diamond Products under this Warranty is limited to replacement or repair of defective parts at Diamond Products' Elyria, Ohio factory, or at a point designated by it, of such parts as shall appear to us upon inspection at such parts, to have been defective in material or workmanship, with expense for transportation and labor borne by Customer.

In no event shall Diamond Products be liable for consequential or incidental damages arising out of the failure of any Product to operate properly.

Integral units such as engines, electric motors, batteries, transmissions, etc., are excluded from this Warranty and are subject to the prime manufacturer's warranty.

THIS WARRANTY IS IN LIEU OF ALL OTHER WARRANTIES, EXPRESSED OR IMPLIED, AND ALL SUCH OTHER WARRANTIES ARE HEREBY DISCLAIMED.



333 Prospect Street, Elyria, Ohio 44035
(440) 323-4616 • (800) 321-5336 • Fax (800) 634-4035
www.diamondproducts.com