



CONCRETE SAW
PARTS LIST

MODEL
CC2500
Electric/Hydraulic

April 7, 2017

Part # 1801981

Blade / Engine Speed (RPM) Chart Model CC2500 Concrete Saw

CAUTION: Do not exceed Bladeshaft speed (RPM) shown for each blade size. Excessive Blade Speed could result in blade breakage and serious personal injury.

Gasoline Engine Speeds				
Blade Size	Bladeshaft		Engine	
	No Load RPM	Sheave Size	No Load RPM	Sheave Size
14"	2,625	4.12"	3,600	3.00
18"	2,625	4.12"	3,600	3.00
20"	2,625	4.12"	3,600	3.00
24"	2,025	4.75"	3,200	3.00
26"	2,025	4.75"	3,200	3.00

Electric Motor Speeds				
Blade Size	Bladeshaft		Motor	
	No Load RPM	Sheave Size	No Load RPM	Sheave Size
14"	2,625	4.12"	3,600	3.00
18"	2,625	4.12"	3,600	3.00
20"	2,625	4.12"	3,600	3.00
24"	2,275	4.75"	3,600	3.00
26"	2,275	4.75"	3,600	3.00

CAUTION: When changing blade size, use chart shown below for selecting items that must be changed.

BLADE SIZE	MAX DEPTH OF CUT
14"	4-3/8"
18"	6-3/8"
20"	7-3/8"
24"	9-3/8"
26"	10-3/8"

MODEL CC2500	14"	20"	26"
Blade Guard Assembly	6010950	6010952	6010954
Bladeshaft Sheave (Sheave Size)	6047947 (4.12")	6047947 (4.12")	6047948 (4.75")

Quick Reference Service Filters/Belts	4	14" Blade Guard Assembly	38
Frame Base Assembly	5	20" Blade Guard Assembly	40
Upright Assembly.....	6	26" Blade Guard Assembly	42
Control Panel Assembly	7	Electric Power Raise/Lower Assembly	44
Belt & Shield Guard Assembly	8	Alternator Assy. Option for 230/460V Electric Saws ...	46
Water Supply Assembly	9	Alternator Assy. Option for 575V Electric Saws.....	48
Frame Lift Assembly.....	10	Hydraulic Power Raise/ Lower Assembly	50
Front Pointer Assembly.....	11	Alternator Assembly Option for Hydraulic Saws	52
Screw Feed Assembly.....	12	Battery Assembly.....	54
Depth Indicator Assembly.....	14	Water Pump Option.....	55
Front Axle Assembly	15	Spot Light Option.....	56
Blade Shaft Assembly, 14& 20" Elec., 26" Hyd.	16	Water Safety Switch Option	57
Blade Shaft Assembly 14-20" Hyd.....	17	Option Wiring Diagram for Electric Raise/ Lower.....	58
Blade Shaft Assembly, 26" Electric	18	Options Wiring Diagram for Hyd. Raise/ Lower.....	59
Rear Axle Assembly.....	19	Options Wiring Diagram for Water Pump	60
Transmission Assembly	20	Options Wiring Diagram for Spotlight	61
15HP-230V Electric Motor Assembly	22	Decal Group	62
15HP-460V Electric Motor Assembly	23	Notes.....	63
15HP-575V Electric Motor Assembly	24	Warranty.....	Rear Cover
Starter Box Assembly, 3-Ph., 230V.....	25		
Starter Box Assembly, 3-Ph., 460V.....	26		
Starter Box Assembly, 3-Ph., 575V.....	27		
Starter Box, 220-240V	28		
Starter Box, 415-480	30		
Starter Box, 550-600	32		
Hydraulic Motor Option for 14"&16" Blade Guards.....	34		
Hydraulic Motor Option for 26" Blade Guards	36		

Quick Reference Service Filters/ Belts

<u>DP Part No.</u>	<u>Description</u>	<u>Manufacturer's Part No.</u>
2500792	Blade Shaft Belt (4)	(Gates #3VX400)
2500849	Transmission Belt	(Gates #4L-500)
2500982	Alternator Belt (Power Raise/ Lower)	(Gates#4L260)

Frame Base Assembly #6047700

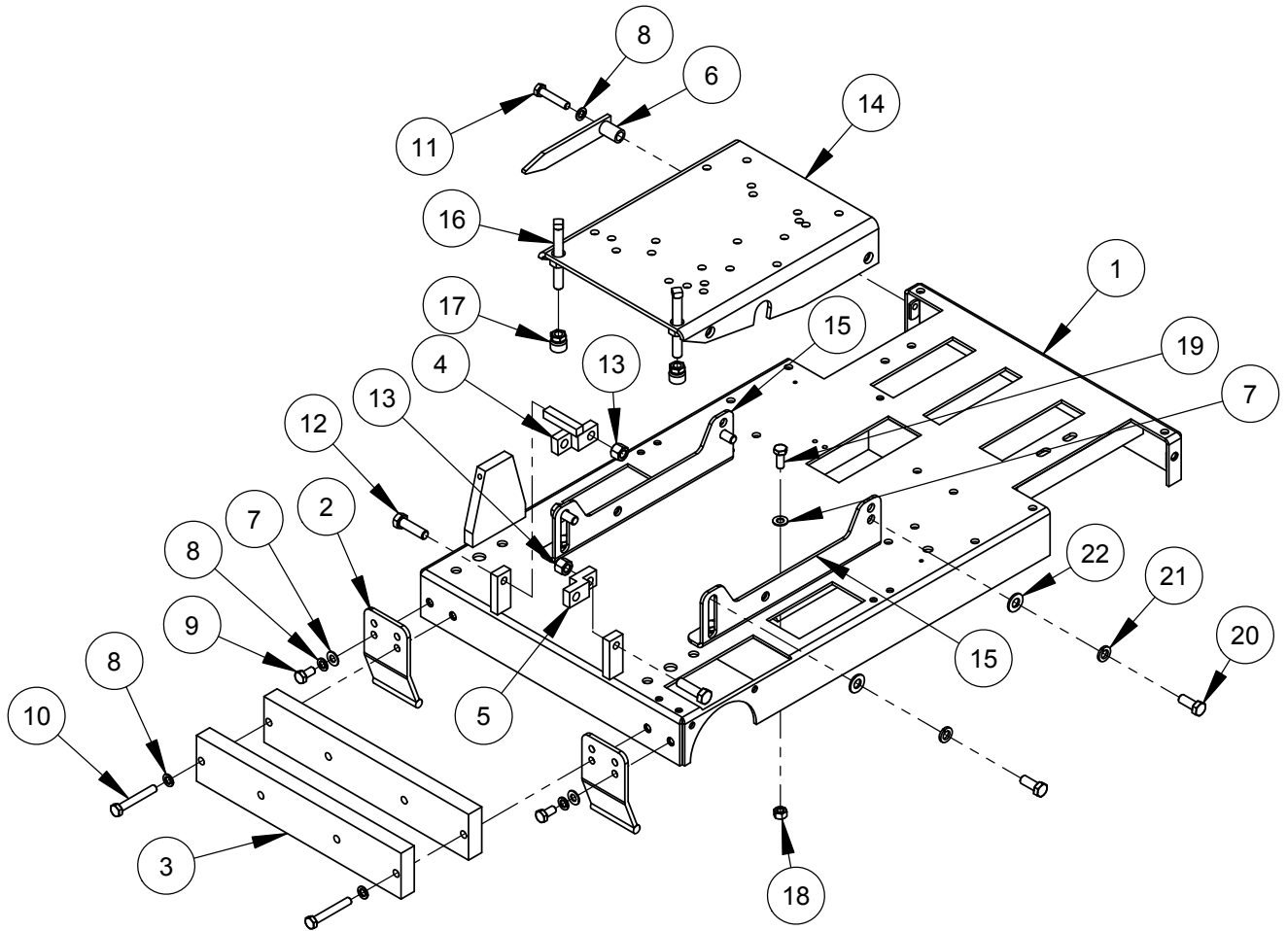

ITEM	PART NO.	QTY.	DESCRIPTION
1	6047900A	1	Frame Base
2	6011021	2	Skid Plate
3	6048067	2	Saw Weight, 13 Pound
4	6047949	1	Pointer Extension with Stop
5	6047976	1	Pointer Extension
6	6010022	1	Rear Pointer
7	2900014	8	Flat Washer, 3/8" SAE
8	2900321	5	Lock Washer, M10 Split
9	2900314	2	Cap Screw, Hex Hd., M10-1.5 x 20mm
10	2900334	2	Cap Screw, Hex Hd., M10-1.5 x 70mm
11	2900318	1	Cap Screw, Hex Hd., M10-1.5 x 50mm
12	2900139	2	Cap Screw, Hex Hd., 1/2-13 x 1-3/4"
13	2900026	2	Lock Nut, 1/2-13 Nylon
14	6041164	1	Engine Base Assembly
15	6047909	2	Engine Base Mount
16	2900027	2	Set Screw, Sq. Hd., 1/2-13 x 4"
17	2900722	2	Swivel Pad, 1/2-13
18	2900304	6	Lock Nut, M10-1.5 Nylon Insert
19	2900333	6	Cap Screw, Hex Hd., M10-1.5 x 25mm
20	2900330	4	Cap Screw, Hex Hd., M12-1.75 x 30mm
21	2900084	4	Lock Washer, 1/2" Split
22	2900058	4	Flat Washer, 1/2" SAE

Upright Assembly #6047701

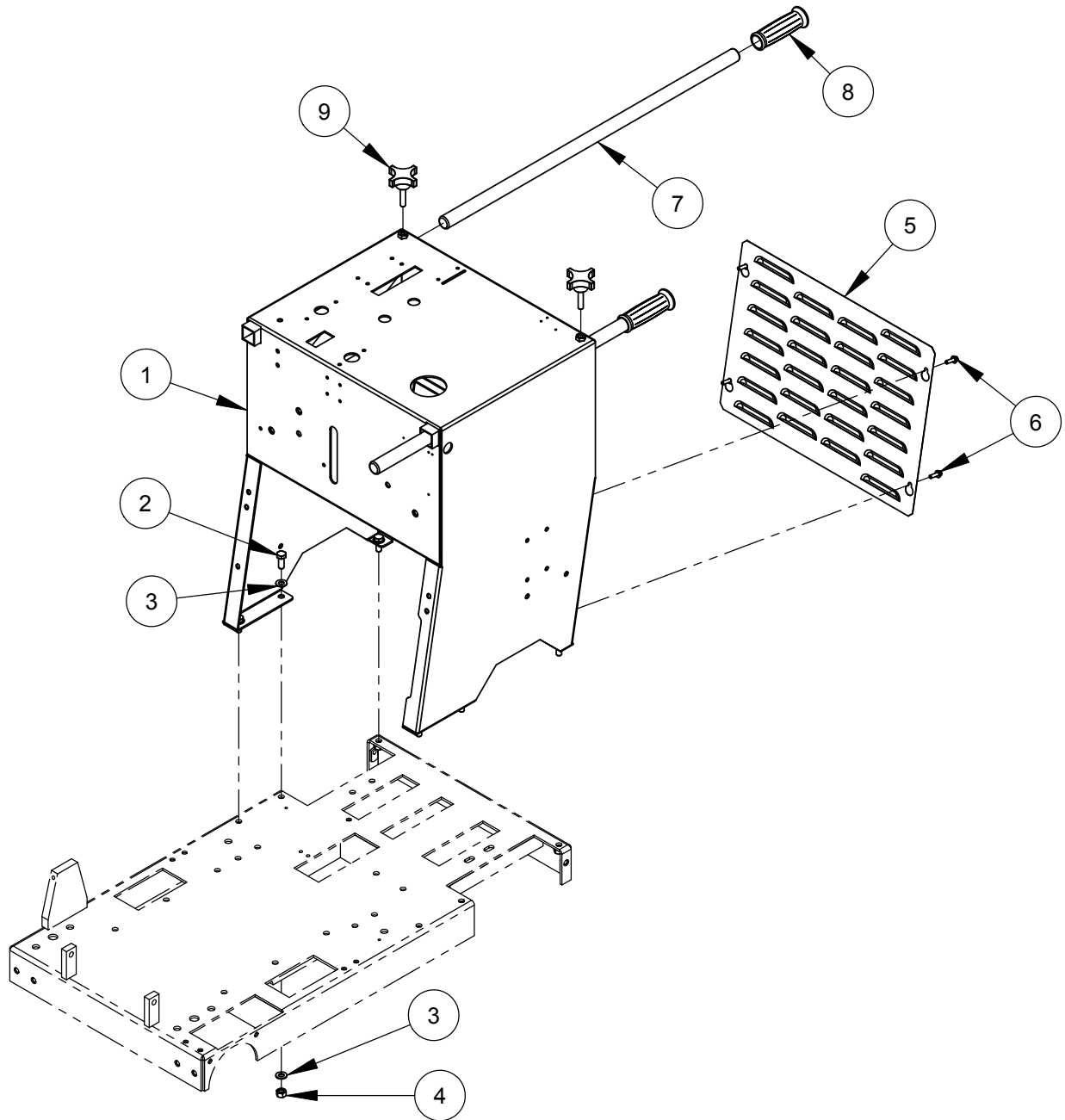

ITEM PART	NO.	QTY.	DESCRIPTION
1	6047901	1	Frame Upright Weldment
2	2900333	6	Cap Screw, Hex Hd., M10 x 25mm
3	2900014	12	Flat Washer, 3/8" SAE
4	2900304	6	Lock Nut, M10-1.5 Nylon Insert
5	6047919	1	Rear Cover Screen
6	2900328	4	Cap Screw, Hex Flange Hd., M6 x 20mm
7	6013054	2	Handle Bar, 30" Long
8	2500636	2	Handle Grip
9	2900234	2	Hand Lock Knob, 3/8"-16

Control Panel Assembly (Electric/Hydraulic)
#6047709

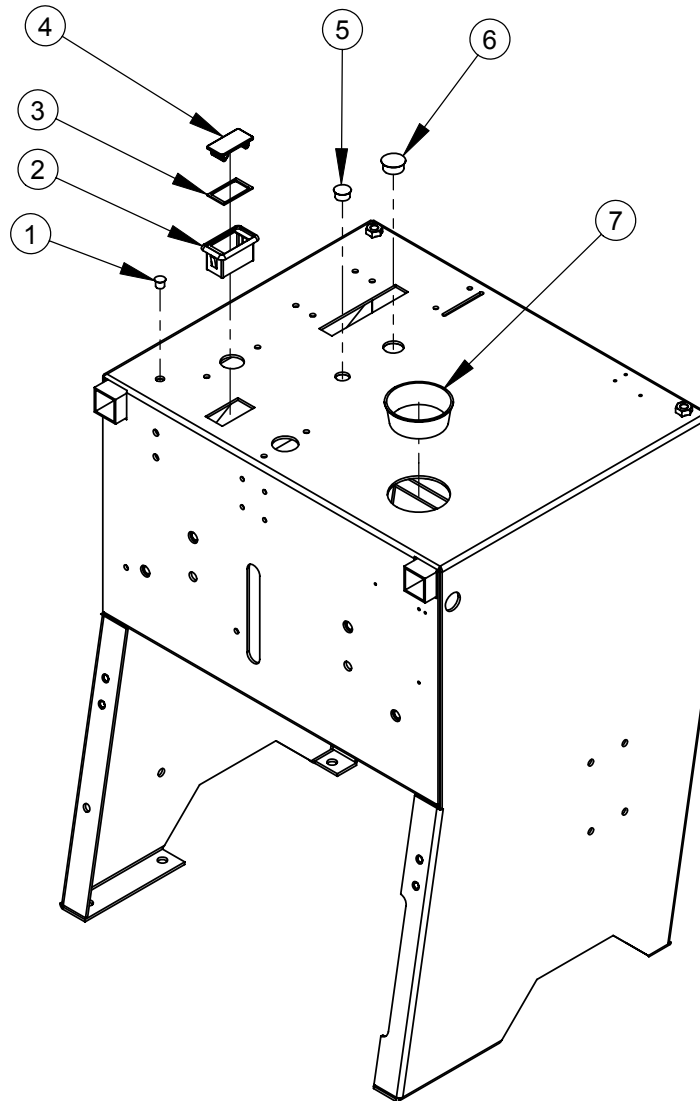

ITEM	PART NO.	QTY.	DESCRIPTION
1	2500462	1	Plug, 3/8" Hole
2	2800260	1	Rocker Mounting Panel
3	2800261	1	Rocker Panel Gasket
4	2800262	1	Rocker Mount Panel Plug
5	2500694	1	Plug, 5/8" Hole
6	2500549	1	Plug, 7/8" Hole
7	2500381	1	Plug, 2-5/8" Tapered Hole

Belt and Shield Guard Assembly
#6047707

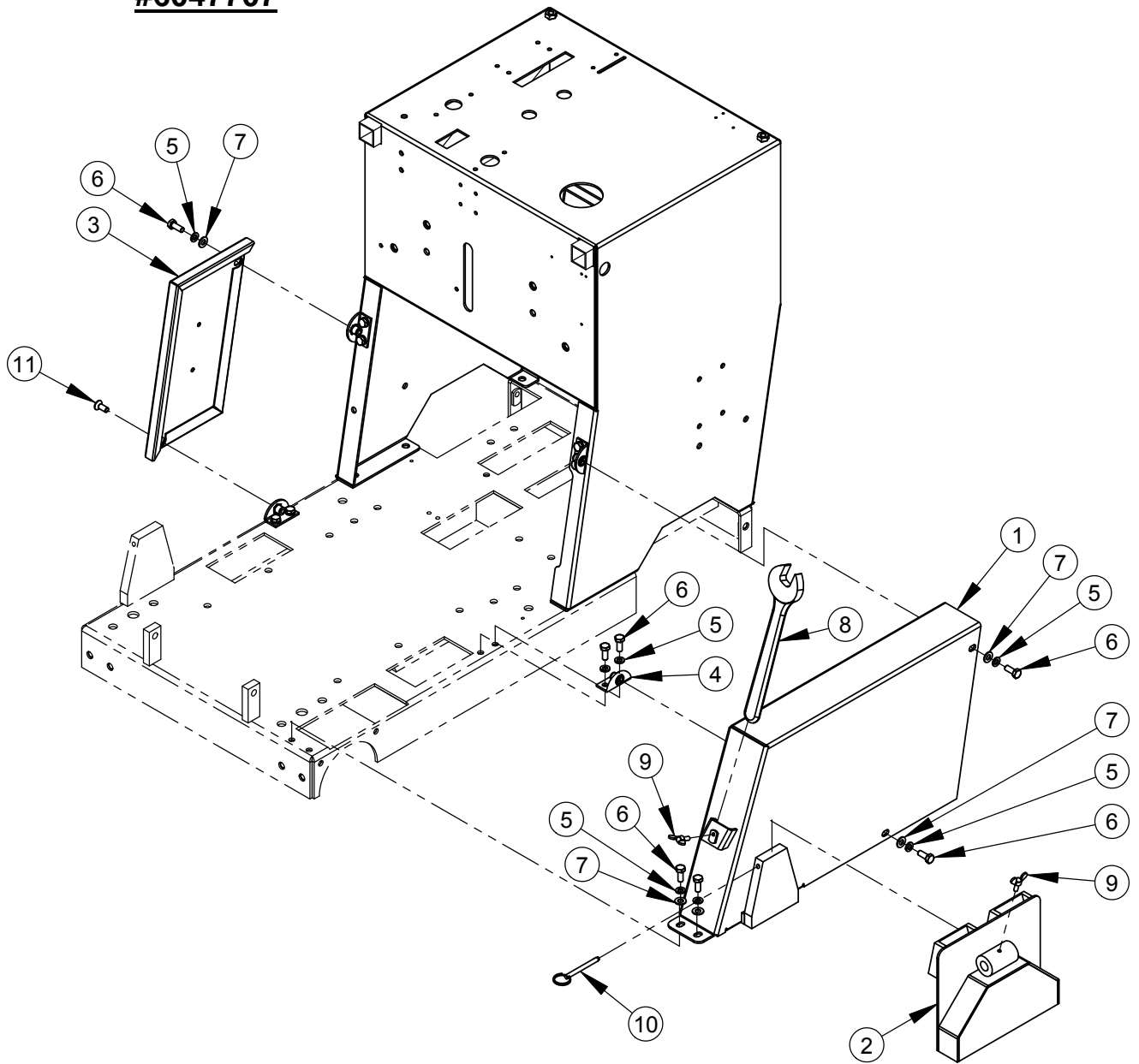

ITEM	PART NO.	QTY.	DESCRIPTION
1	6047917A	1	Belt Guard Weldment
2	6010555	1	Shaft/Flange Guard (Narrow)
3	6048062	1	Slurry Shield
4	6048064	4	Guard Mounting Tab Assembly, 90 Deg.
5	2900031	13	Lock Washer, 5/16" Split
6	2900329	13	Cap Screw, Hex Hd., M8-1.25 x 20mm
7	2900022	5	Flat Washer, 5/16" SAE
8	2500211	1	Wrench, 15/16" Open End
9	2900307	2	Wing Screw, M6 x 16mm
10	2900156	1	Lock Pin with Ring
11	2900611	1	Cap Screw, Flat Hd., M8-1.25 x 20mm

Water Supply Assembly #6047703

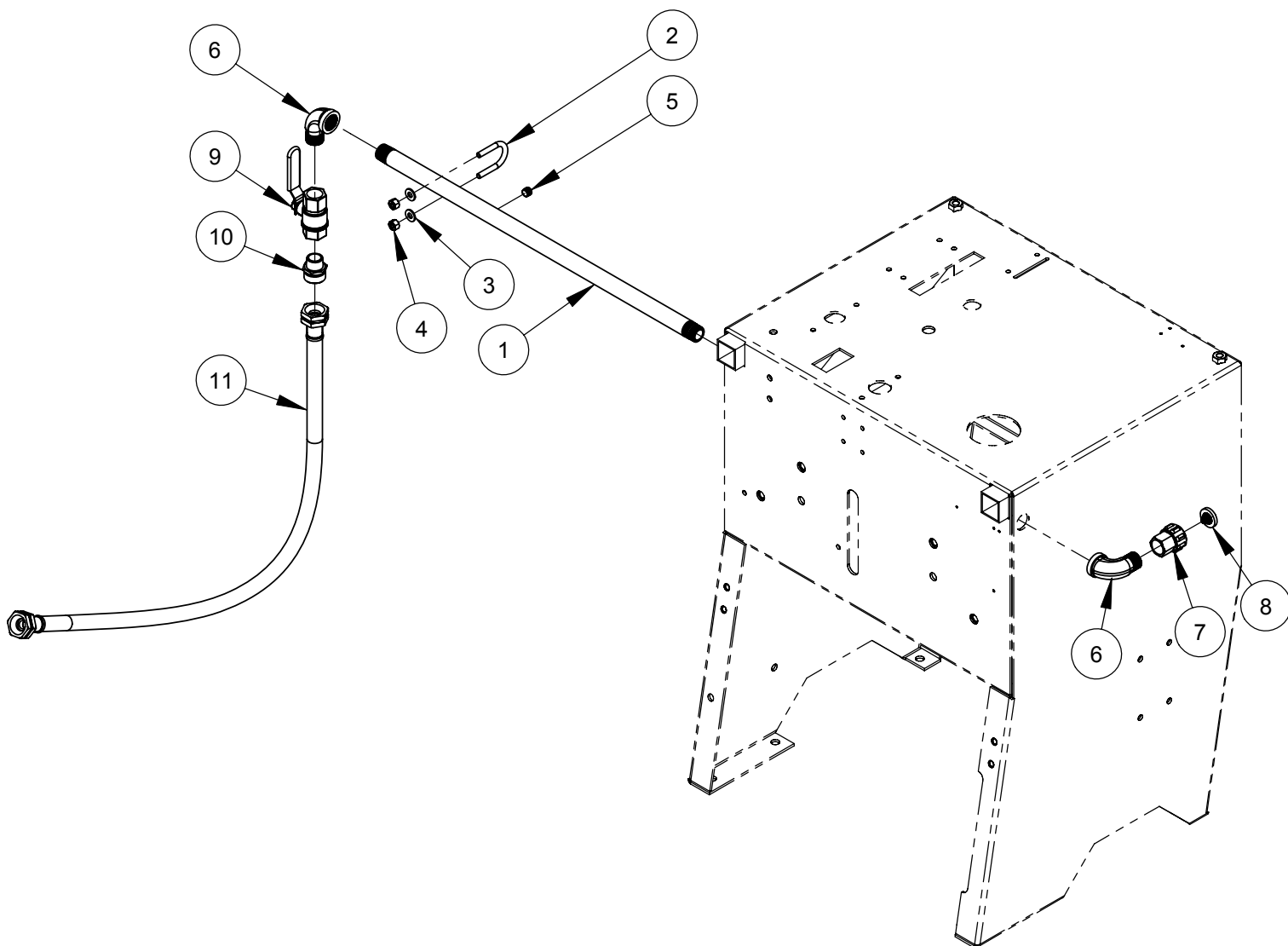

ITEM PART	NO.	QTY.	DESCRIPTION
1	6047938	1	Water Supply Tube
2	2900241	1	U-Bolt, 1/2" Pipe
3	2900009	2	Flat Washer, 1/4" SAE
4	2900010	2	Lock Nut, 1/4-20 Nylon
5	3200001	1	Plug, 1/8" NPT
6	3200013	2	Street Elbow, 1/2" NPT
7	3200022	1	Fitting, 1/2" F. Pipe to 3/4" F. Garden
8	3200025	1	Hose Filter Washer
9	3200027	1	Water Valve
10	3200155	1	Fitting, 1/2" M. Pipe to 3/4" M. Garden
11	6010021	1	Water Hose Assembly, 42" Long

Frame Lift Assembly #6047706

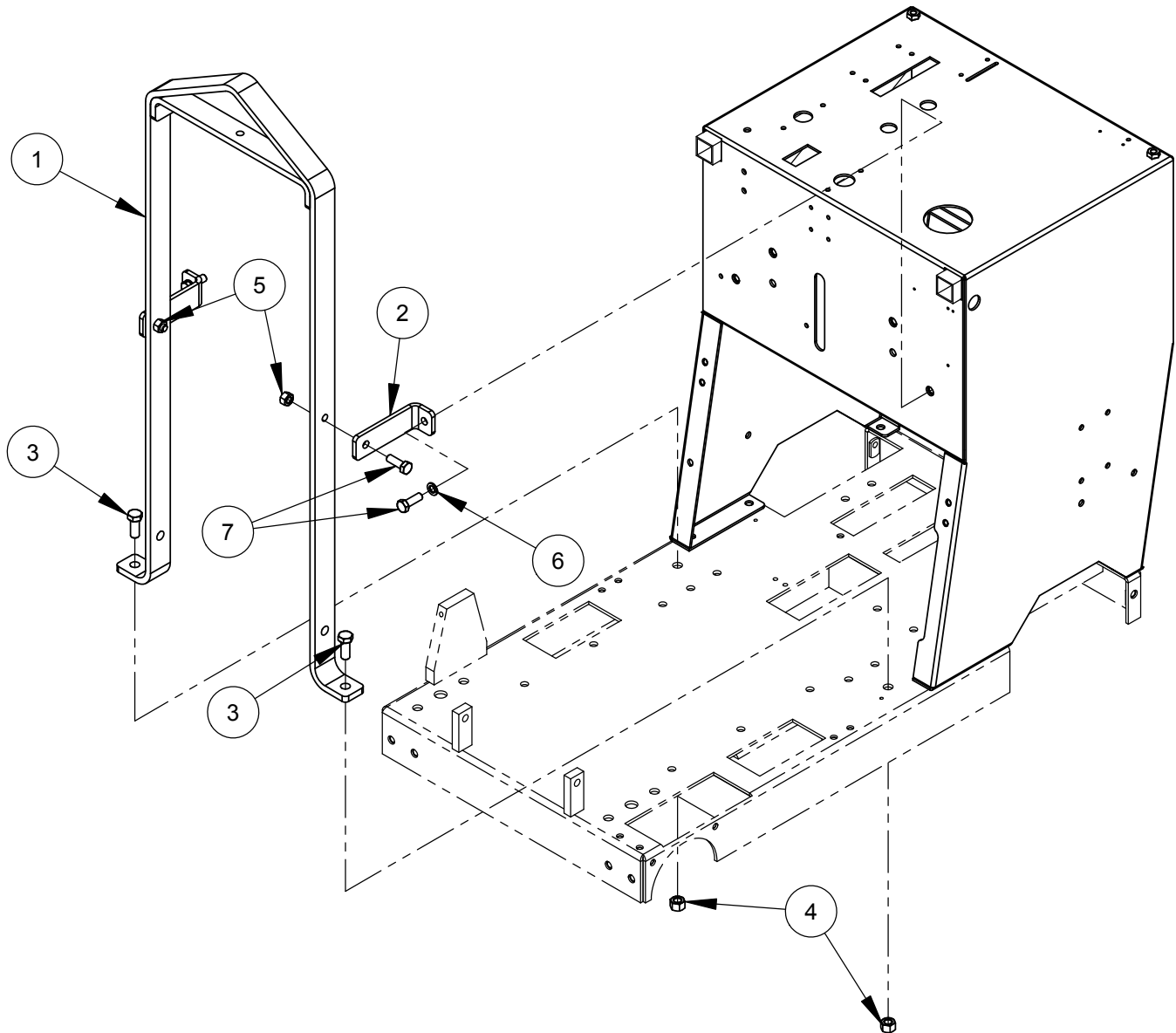

ITEM PART	NO.	QTY.	DESCRIPTION
1	6047952	1	Frame Lift
2	6047953	2	Frame Lift Brace
3	2900330	2	Cap Screw, Hex Hd., M12-1.75 x 30mm
4	2900327	2	Lock Nut, M12-1.75 Nylon Insert
5	2900304	2	Lock Nut, M10-1.5 Nylon Insert
6	2900321	2	Lock Washer, M10 Split
7	2900223	4	Cap Screw, Hex Hd., M10-1.5 x 30mm

Dual Front Pointer Assembly #6011540

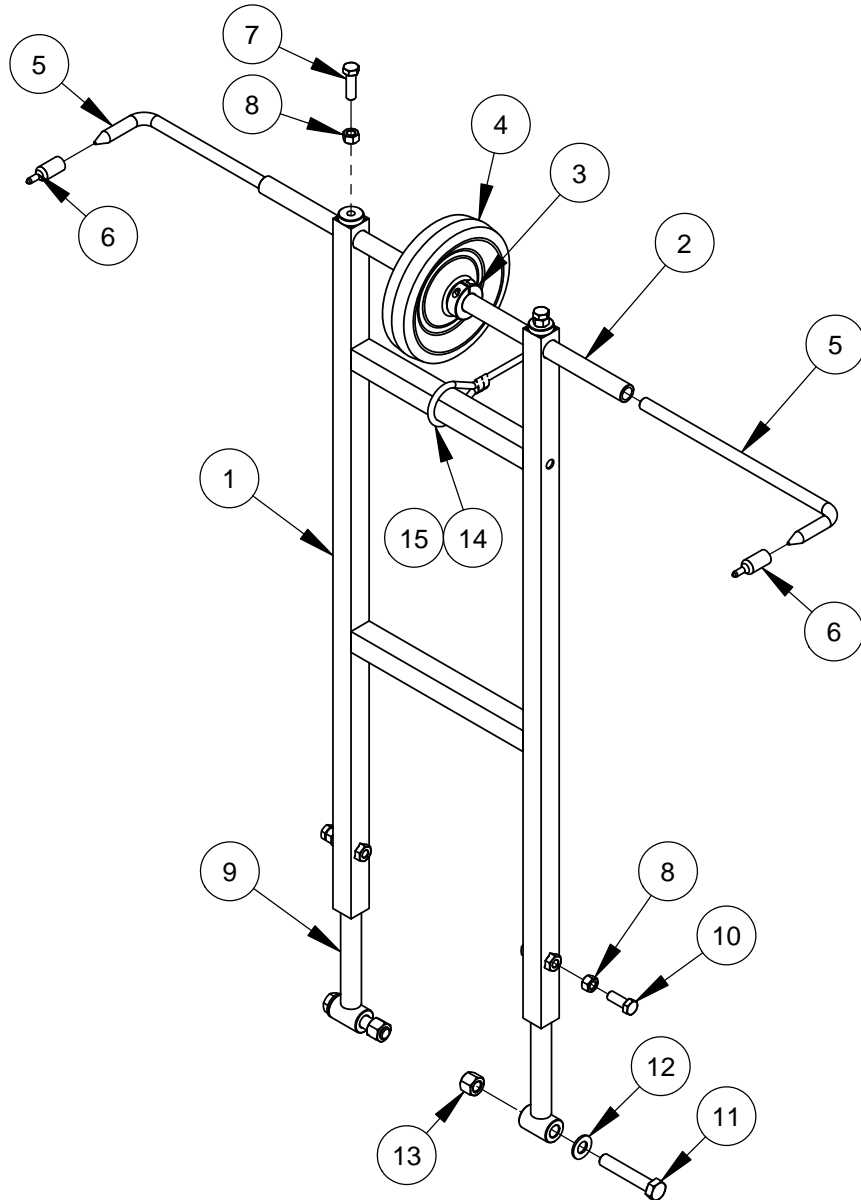

ITEM	PART NO.	QTY.	DESCRIPTION
1	6011537	1	Front Pointer Frame
2	6011539	1	Pointer Tube, 20"
3	2504577	2	Shaft Collar, 3/4" Split
4	2504581	1	Wheel, 6"
5	6011535	2	Front Pointer Rod, 11"
6	2500740	2	Pointer Cap
7	2900013	2	Cap Screw, Hex Hd., 3/8-16 x 1-1/4"
8	2900033	4	Hex Nut, 3/8-16
9	6011152	2	Front Pointer Arm
10	2900005	2	Cap Screw, Hex Hd., 3/8-16 x 1"
11	2900105	2	Cap Screw, Hex Hd., 1/2-13 x 2-3/4"
12	2900239	2	Friction Washer, 1/2"
13	2900026	2	Lock Nut, 1/2-13 Nylon
14	6017241	1	Pointer Rope 11 Foot
15	3200221	2	Pinch Clamp, Two Ear

Screw Feed Assembly
#6047702

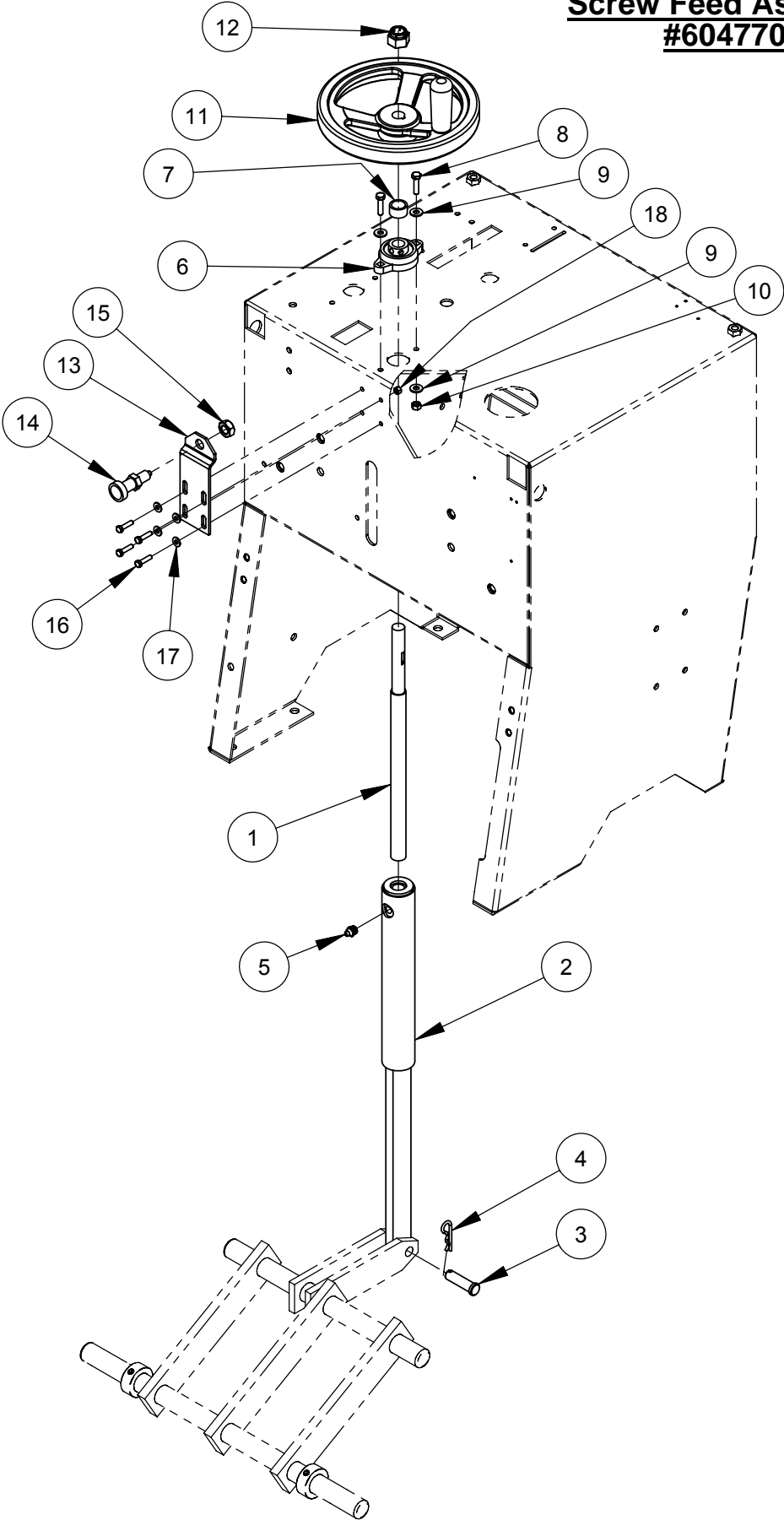

Screw Feed Assembly
#6047702

ITEM PART	NO.	QTY.	DESCRIPTION
1	6047929	1	Adjustment Screw
2	6047927	1	Adjustment Shaft
3	2900354	1	Clevis Pin, 1/2" x 1-3/4"
4	2900276	1	Hairpin Cotter, 1/8" x 1/2" to 3/4"
5	2900062	1	Grease Fitting, 1/8" NPT
6	2500807	1	Bearing, 5/8", Two Bolt Flange
7	6047931	1	Spacer Tube 7/8 x 1/2
8	2900311	2	Cap Screw, Hex Hd., M6 x 25mm
9	2900009	4	Flat Washer, 1/4" SAE
10	2900302	2	Lock Nut, M6 Nylon
11	2500800	1	Handwheel, 8" x 5/8"
12	2900355	1	Lock Nut, 5/8-18, Flex Top
13	6047216	1	Bracket, Handwheel Lock
14	2400138	1	Indexing Plunger, 1/2-13 UNC
15	2900129	1	Jam Nut, 1/2-13
16	2900309	4	Cap Screw, Hex Hd., M5 x 20mm
17	2900016	4	Flat Washer, #10 USS
18	2900301	4	Lock Nut, M5 Nylon

6047946 CC2500
Depth Indicator Assembly

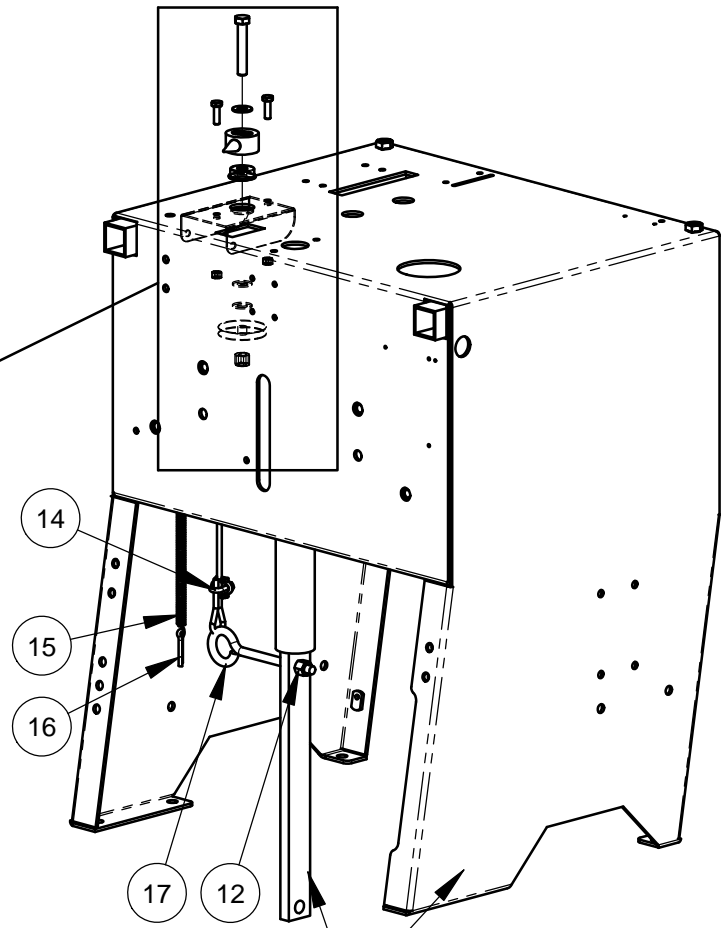
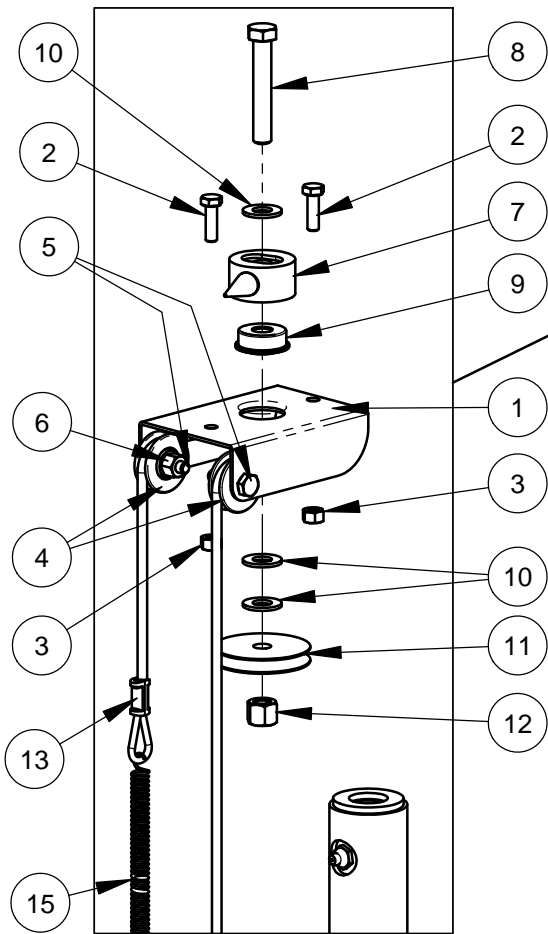

Shown as Reference

DETAIL A
SCALE 1 : 4

ITEM	PART NO.	QTY.	DESCRIPTION
1	6010092	1	Depth Indicator Mount Bracket
2	2900310	2	Cap Screw, Hex Hd., M6-1.0 x 20mm
3	2900302	2	Lock Nut, M6-1.0 Nylon Insert
4	2500155	2	Cable Pulley, 1-1/4"
5	2900008	2	Cap Screw, Hex Hd., 1/4-20 x 1"
6	2900010	2	Lock Nut, 1/4-20 Nylon
7	6010091	1	Depth Indicator Pointer
8	2900079	1	Cap Screw, Hex Hd., 3/8-16 x 2-1/4"
9	2500145	1	Flange Bearing, 3/8"
10	2900014	3	Flat Washer, 3/8" SAE
11	6010093	1	Cable Pulley, 2"
12	2900018	2	Locknut, 3/8-16, Nylon
13	6047989	1	Depth Indicator Cable
14	2500214	1	Cable Clamp
15	2500799	1	Depth Indicator Spring 11"
16	2900055	1	Cotter Pin, 3/16" x 1"
17	2900964	1	Eyebolt, 3/8-16 x 6"

Front Axle Assembly #6047936

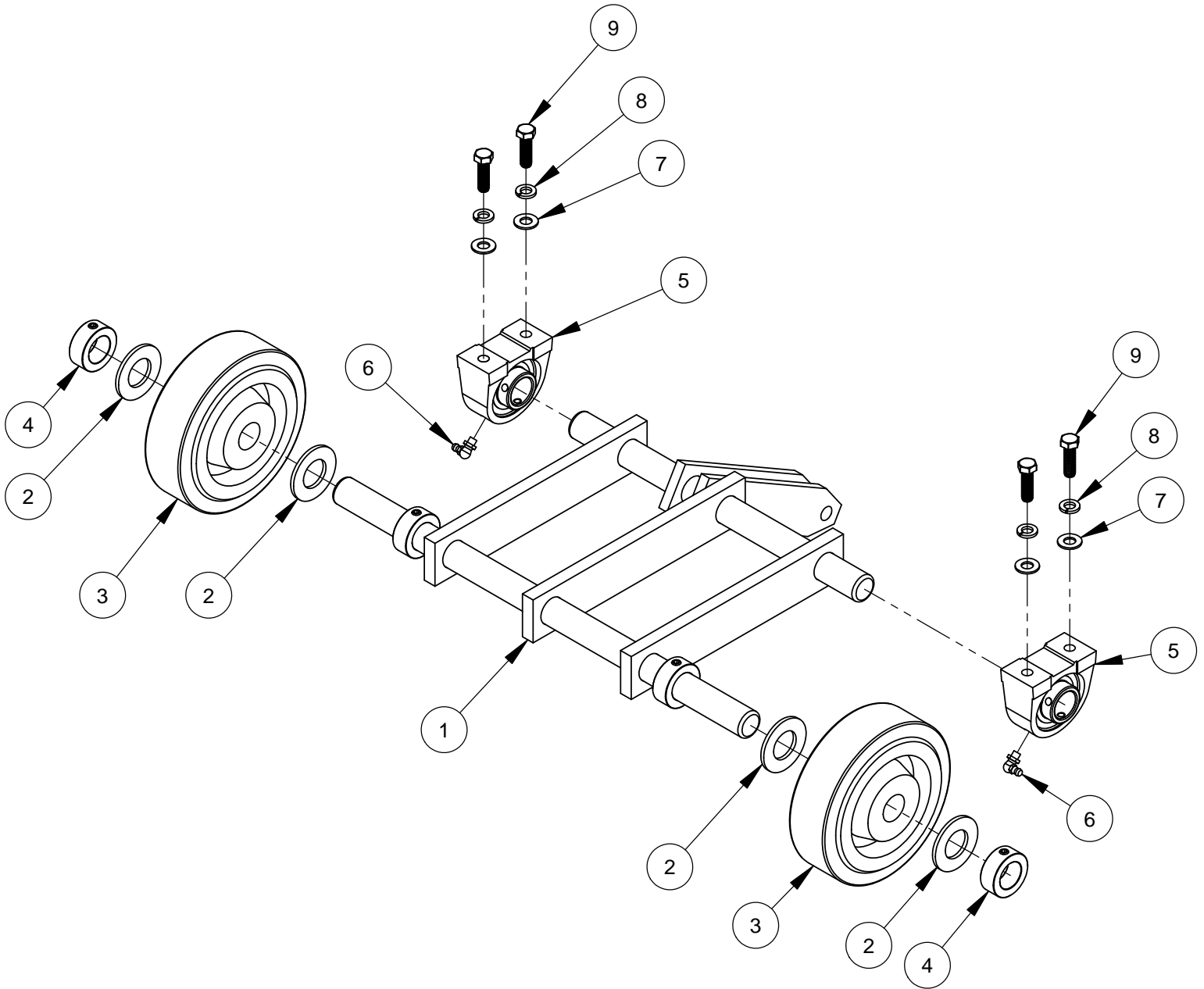

ITEM	PART NO.	QTY.	DESCRIPTION
1	6047902	1	Front Axle Weldment
2	2900295	4	Flat Washer, 1" SAE
3	2500299	2	Wheel, 6" X 2" X 1"
4	2500009	2	Set Collar, 1" ID
5	2500732	2	Pillow Block Bearing 1"
6	2900061	2	Grease Fitting, 1/4-28 x 90 Degree
7	2900014	4	Flat Washer, 3/8" SAE
8	2900006	4	Lock Washer, 3/8" Split
9	2900013	4	3/8-16 X 1.25" Hex Cap Screw

Blade Shaft Assembly (14, 20" Gas/Electric, 26" Hydraulic)

#6047940

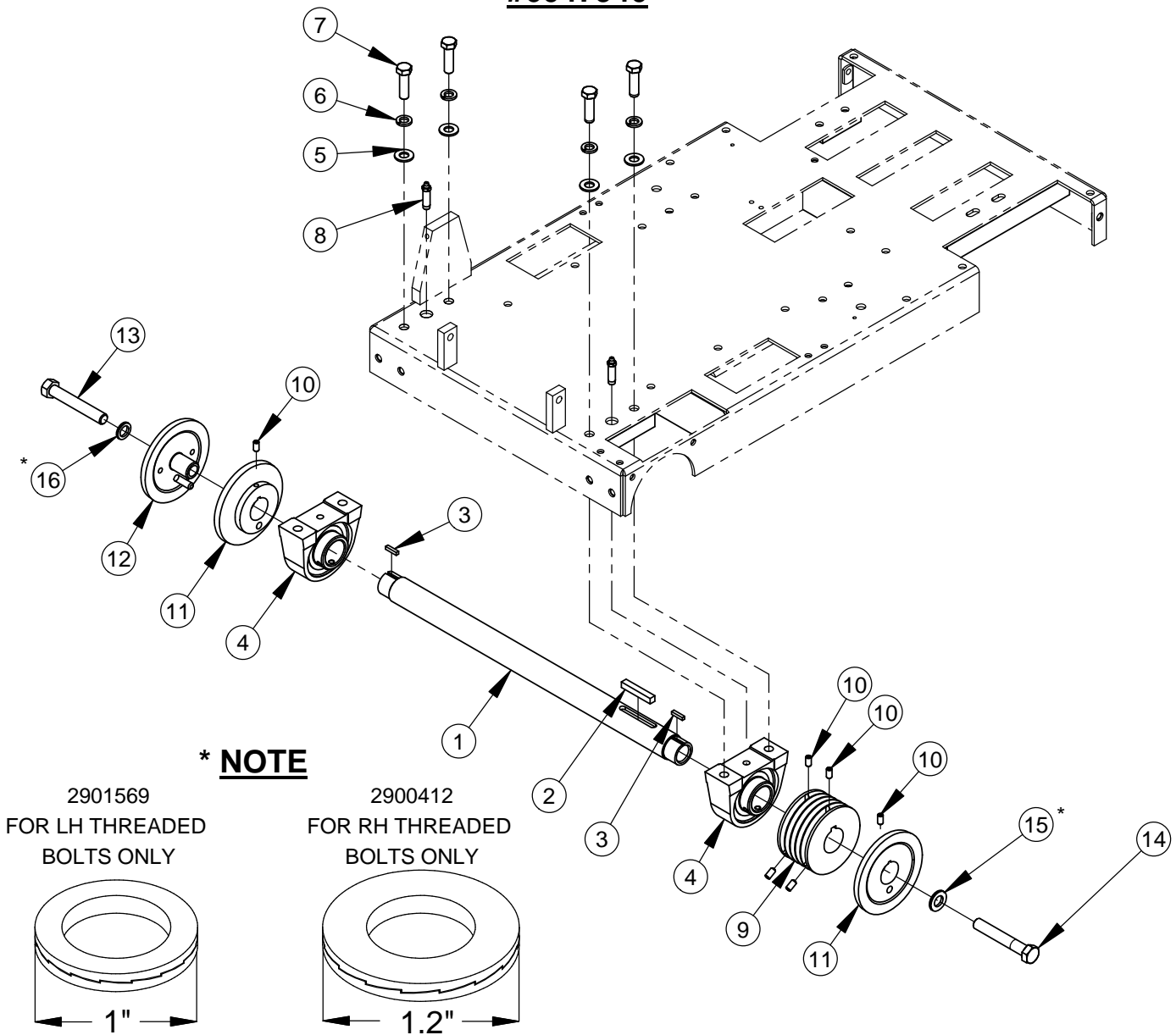

ITEM	PART NO.	QTY.	DESCRIPTION
1	6047905	1	Blade Shaft
2	6047959	1	Key, 3/8" Sq. x 2-1/4"
3	6047978	2	Key, 3/16" Sq. x 27/32"
4	2500731	2	Pillow Block Bearing 1-1/2"
5	2900058	4	Flat Washer, 1/2" SAE
6	2900084	4	Lock Washer, 1/2" Split
7	2900139	4	Cap Screw, Hex Hd., 1/2-13 x 1-3/4"
8	2900264	2	Grease Fitting, 1/8" NPT x 1-3/4"
9	6047947	1	Sheave, 4.12" x 1-1/2" Bore
10	2900418	6	Set Screw, Soc. Hd., 5/16-18 x 5/8"
11	6047906	2	Inner Flange 5"
12	6047907	1	Outer Flange 5" with Pin
13	2900130	1	Cap Screw, Hex Hd., 5/8-11 x 4" LH
14	2900146	1	Cap Screw, Hex Hd., 5/8-11 x 4"
15	2900412	1	Lock Washer, Wedge 5/8"
16	2901569	1	Lock Washer, Wedge 5/8" LH

* See Note

* See Note

Blade Shaft Assembly (14 - 20" Hydraulic) #6047995

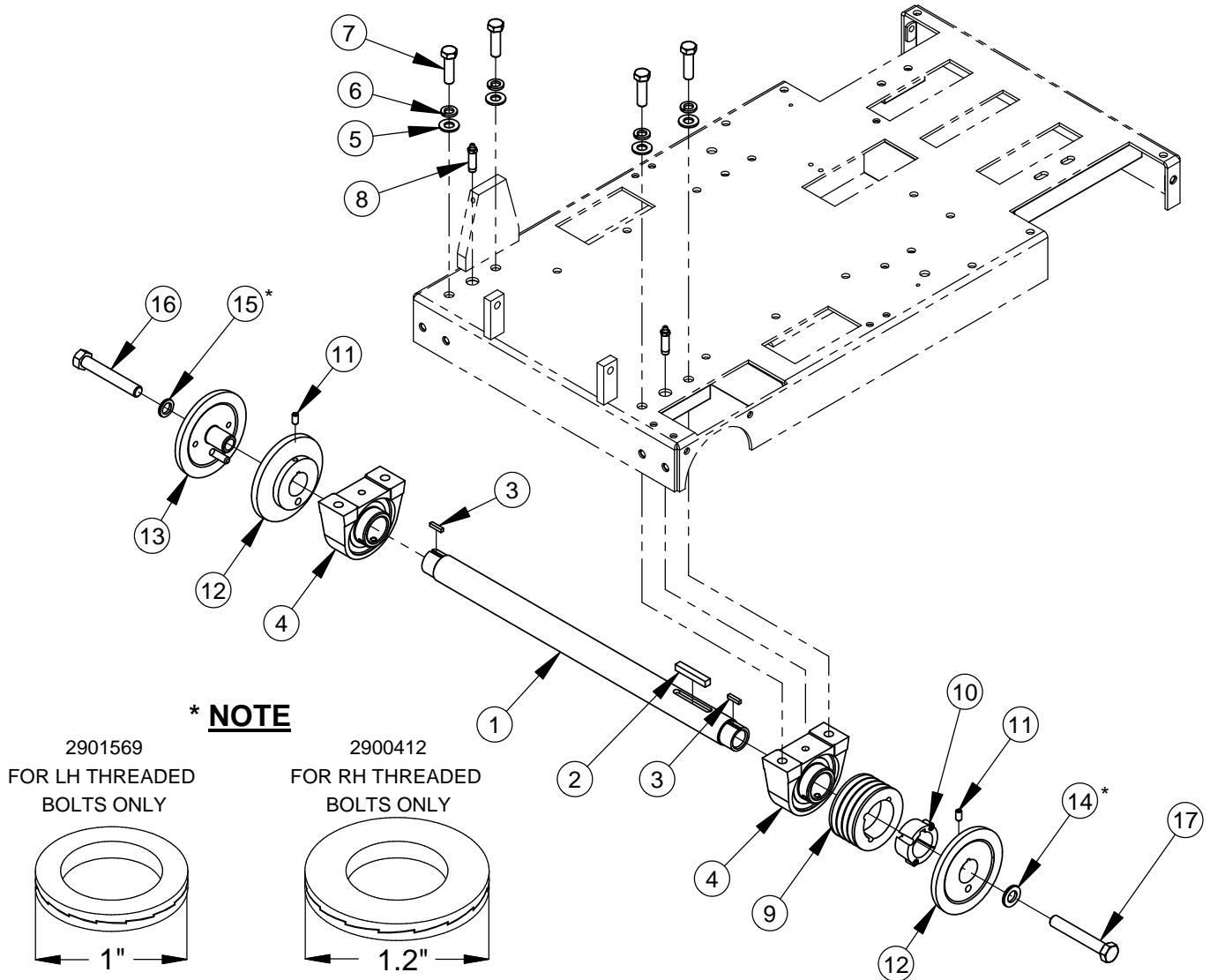

ITEM	PART NO.	QTY.	DESCRIPTION
1	6047905	1	Blade Shaft
2	6047959	1	Key, 3/8" Sq. x 2-1/4"
3	6047978	2	Key, 3/16" Sq. x 27/32"
4	2500731	2	Pillow Block Bearing 1-1/2"
5	2900058	4	Flat Washer, 1/2" SAE
6	2900084	4	Lock Washer, 1/2" Split
7	2900139	4	Cap Screw, Hex Hd., 1/2-13 x 1-3/4"
8	2900264	2	Grease Fitting, 1/8" NPT x 1-3/4"
9	2500621	1	Sheave, 3V-3.65-4 Groove (1610)
10	2500363	1	Taper Bushing, 1-1/2" w/ Set Screws
11	2900418	2	Set Screw, Soc. Hd., 5/16-18 x 5/8"
12	6047906	2	Inner Flange 5"
13	6047907	1	Outer Flange 5" with Pin
14	2900412	1	Lock Washer, Wedge 5/8"
15	2901569	1	Lock Washer, Wedge 5/8" LH
16	2900130	1	Cap Screw, Hex Hd., 5/8-11 x 4" LH
17	2900146	1	Cap Screw, Hex Hd., 5/8-11 x 4"

* See Note

* See Note

Blade Shaft Assembly (26" Gas/Electric)
#6047941

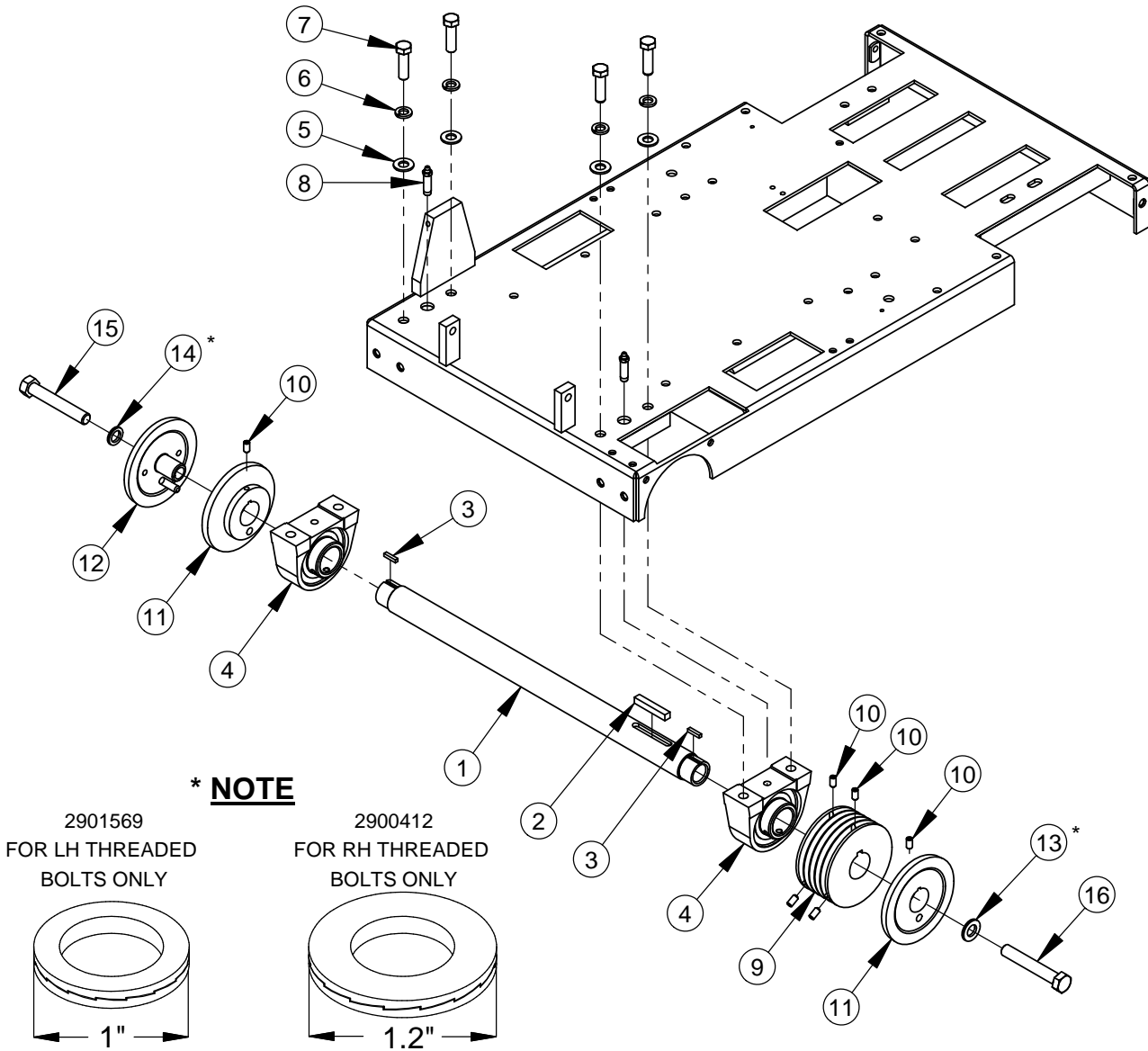

ITEM	PART NO.	QTY.	DESCRIPTION
1	6047905	1	Blade Shaft
2	6047959	1	Key, 3/8" Sq. x 2-1/4"
3	6047978	2	Key, 3/16" Sq. x 27/32"
4	2500731	2	Pillow Block Bearing 1-1/2"
5	2900058	4	Flat Washer, 1/2" SAE
6	2900084	4	Lock Washer, 1/2" Split
7	2900139	4	Cap Screw, Hex Hd., 1/2-13 x 1-3/4"
8	2900264	2	Grease Fitting, 1/8" NPT x 1-3/4"
9	6047948	1	Sheave, 4.75" x 1-1/2" Bore
10	2900418	6	Set Screw, Soc. Hd., 5/16-18 x 5/8"
11	6047906	2	Inner Flange 5"
12	6047907	1	Outer Flange 5" with Pin
13	2900412	1	Lock Washer, Wedge 5/8"
14	2901569	1	Lock Washer, Wedge 5/8" LH
15	2900130	1	Cap Screw, Hex Hd., 5/8-11 x 4" LH
16	2900146	1	Cap Screw, Hex Hd., 5/8-11 x 4"

* See Note

* See Note

Rear Axle Assembly #6047993

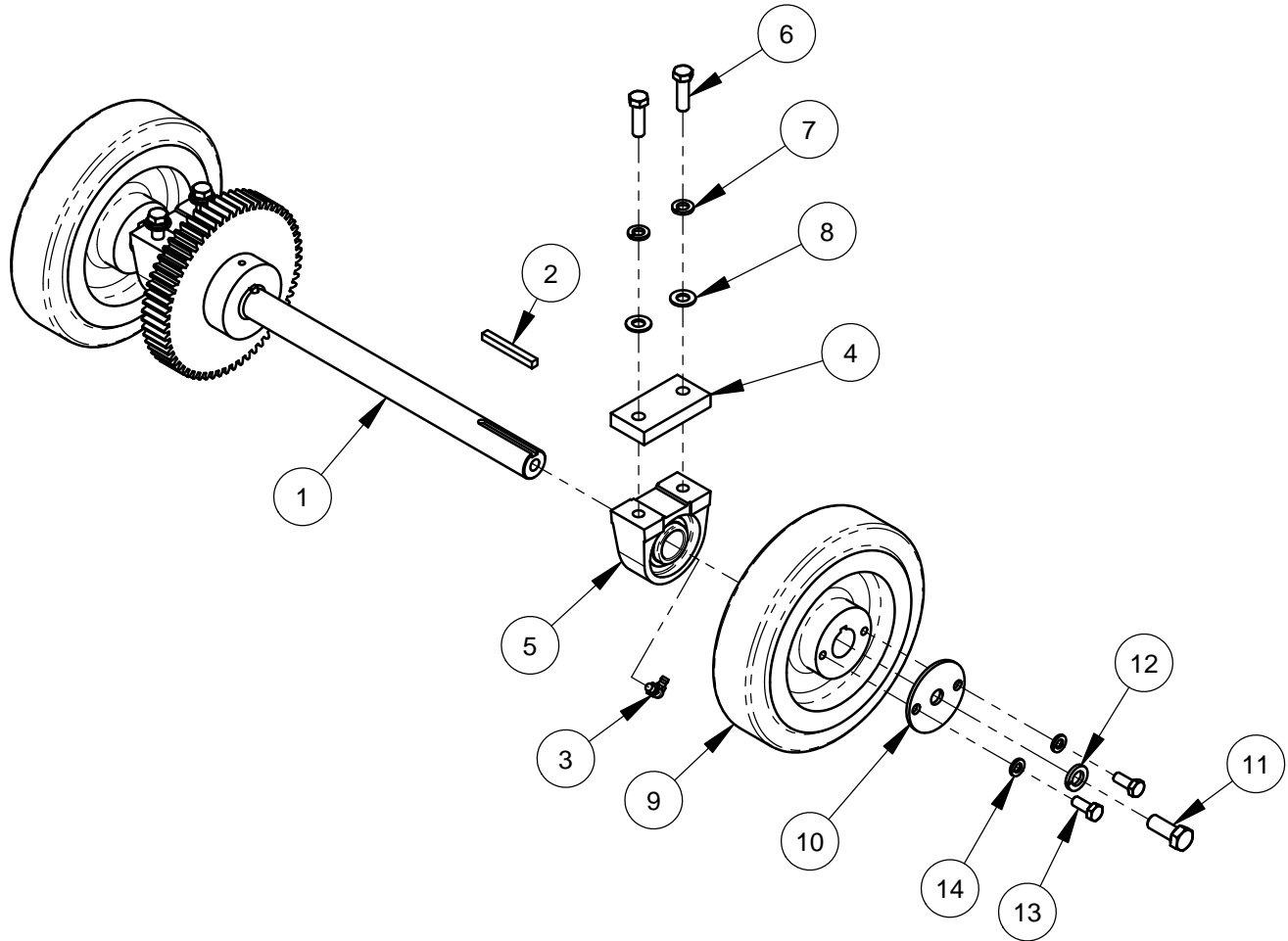

ITEM	PART NO.	QTY.	DESCRIPTION
1	6047982	1	Rear Axle Weldment w/ 60 Tooth Spur Gear
2	6048134	2	Key, 1/4" Sq. x 2-1/4"
3	2900061	2	Grease Fitting, 1/4-28 x 90 Degree
4	6047904	1	Axle Bearing Spacer 1/2"
5	2500732	2	Pillow Block Bearing 1"
6	2900013	4	Cap Screw, Hex Hd., 3/8-16 x 1-1/4"
7	2900006	4	Lock Washer, 3/8" Split
8	2900014	4	Flat Washer, 3/8" SAE
9	2500724	2	Wheel, 8" Rear
10	6010026	2	Wheel Mount Washer
11	2900330	2	Cap Screw, Hex Hd., M12-1.75 x 30mm
12	2900084	2	Lock Washer, 1/2" Split
13	2900329	4	Cap Screw, Hex Hd., M8-1.25 x 20mm
14	2900031	4	Lock Washer, 5/16" Split

Transmission Assembly #6047962

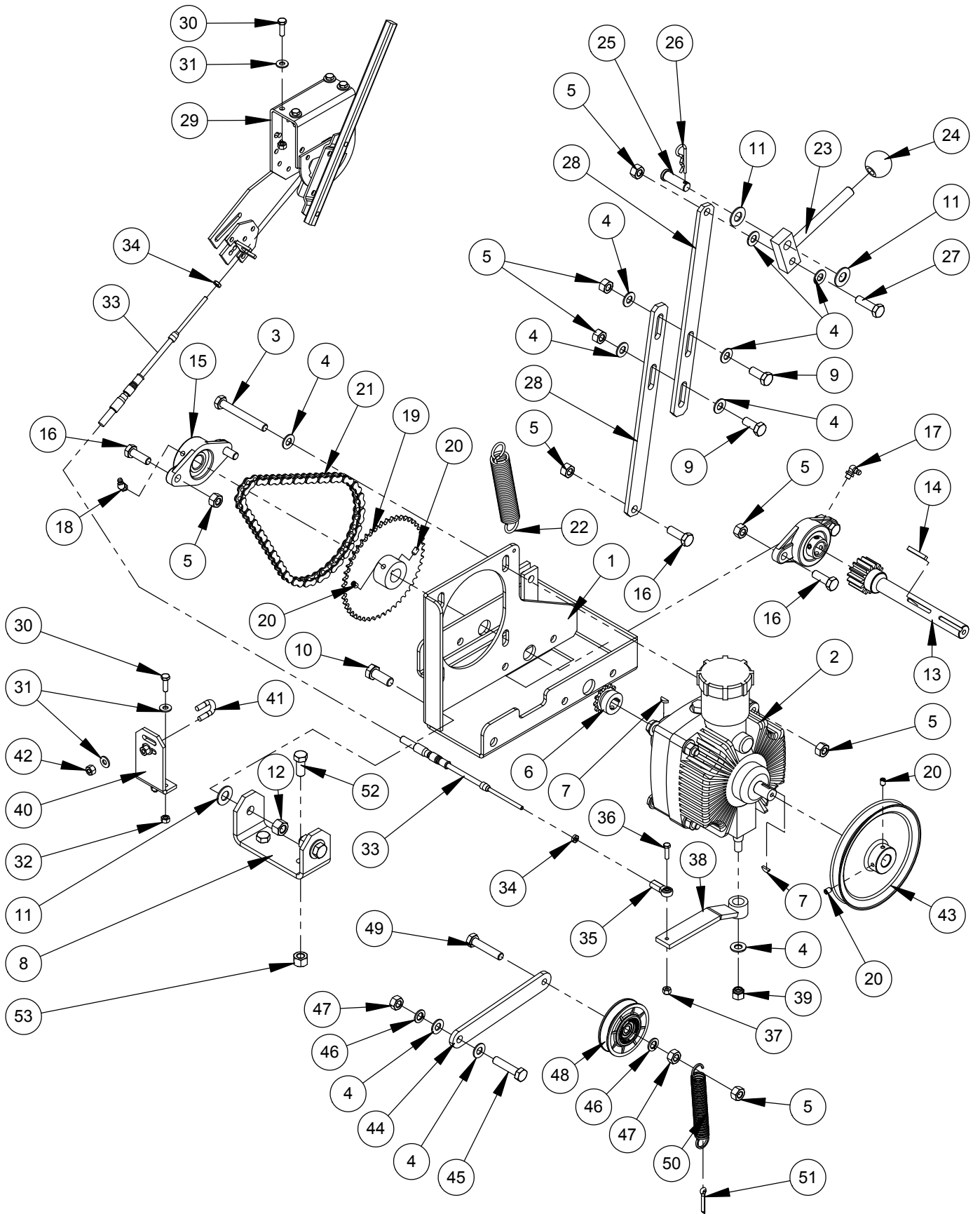

Transmission Assembly #6047962

ITEM	PART NO.	QTY.	DESCRIPTION
1	6047923	1	Transmission Platform Weldment
2	2600015	1	Eaton 6 Transmission
3	2900319	4	Cap Screw, Hex Hd., M10-1.5 x 80mm
4	2900014	13	Flat Washer, 3/8" SAE
5	2900304	13	Lock Nut, M10-1.5 Nylon Insert
6	2500017	1	SProcket, 12 Teeth W/ 1/4 Setscrew
7	2900068	2	Woodruff Key #404, 1/8" W x 1/2" Dia.
8	6047924	1	Transmission Pivot Support
9	2900333	2	Cap Screw, Hex Hd., M10-1.5 x 25mm
10	2900330	2	Cap Screw, Hex Hd., M12-1.75 x 30mm
11	2900058	4	1/2 FLAT WASHER
12	2900327	2	Lock Nut, M12-1.75 Nylon Insert
13	6010080	1	Transmission Jackshaft 15T
14	6048229	1	Key, 3/16" Sq. x 1-1/4"
15	2500011	2	Flange Mt. Bearing 3/4"
16	2900223	5	Cap Screw, Hex Hd., M10-1.5 x 30mm
17	2900061	1	Grease Fitting, 1/4-28 x 90 Degree
18	2900184	1	Grease Fitting, 1/4" NPT x 45 degree
19	2500018	1	Sprocket, 48 Teeth w/ Setscrews
20	2900101	4	Set Screw, Soc. Hd., 1/4-20 x 3/8"
21	6048232	1	Chain, #35 x 63 Pitch
22	2500780	1	Spring, 1" Dia. x 6"
23	6048057	1	Engagement Lever
24	2400007	1	Knob, 1/2-20 x 1-3/8" Dia.
25	2900277	1	Clevis Pin, 1/2" Dia. x 1-1/2"
26	2900276	1	Hairpin Cotter, 1/8" x 1/2" to 3/4"
27	2900315	1	Cap Screw, Hex Hd., M10-1.5 x 35mm
28	6047925	2	Linkage
29	2500805	1	Quadco Speed Control
30	2900310	6	Cap Screw, Hex Hd., M6-1.0 x 20mm
31	2900009	8	Flat Washer, 1/4" SAE
32	2900302	6	Lock Nut, M6-1.0 Nylon Insert
33	2500806	1	Speed Control Cable
34	2900188	2	Hex Nut, #10-32
35	2500791	1	Rod End, #10-32 Female
36	2900015	1	Machine Screw, Hex Hd., #10-24 x 3/4"
37	2900017	1	Lock Nut, #10-24 Nylon
38	6047926	1	Shift Lever
39	2900018	1	Lock Nut, 3/8-16 Nylon
40	6047943	1	Cable Control Bracket
41	2500818	1	Clamp, 3/16" Cable
42	2900010	2	Lock Nut, 1/4-20 Nylon
43	2500016	1	Pulley, 6"
44	6048085	1	Idler Arm
45	2900317	1	Cap Screw, Hex Hd., M10-1.5 x 45mm
46	2900321	2	Lock Washer, M10 Split
47	2900325	2	Hex Nut, M10-1.5
48	2500074	1	Idler Pulley 3"
49	2900337	1	Cap Screw, Hex Hd., M10-1.5 x 50mm, Full Thd.
50	2500070	1	Spring, Extension, 3/4 Dia x 4
51	2900055	1	Cotter Pin, 3/16" x 1"
52	2900407	2	Cap Screw, Hex Hd., 7/16-14 x 1"
53	2900045	2	Lock Nut, 7/16-14 Nylon

15HP-230V Electric Motor Assembly #6047712

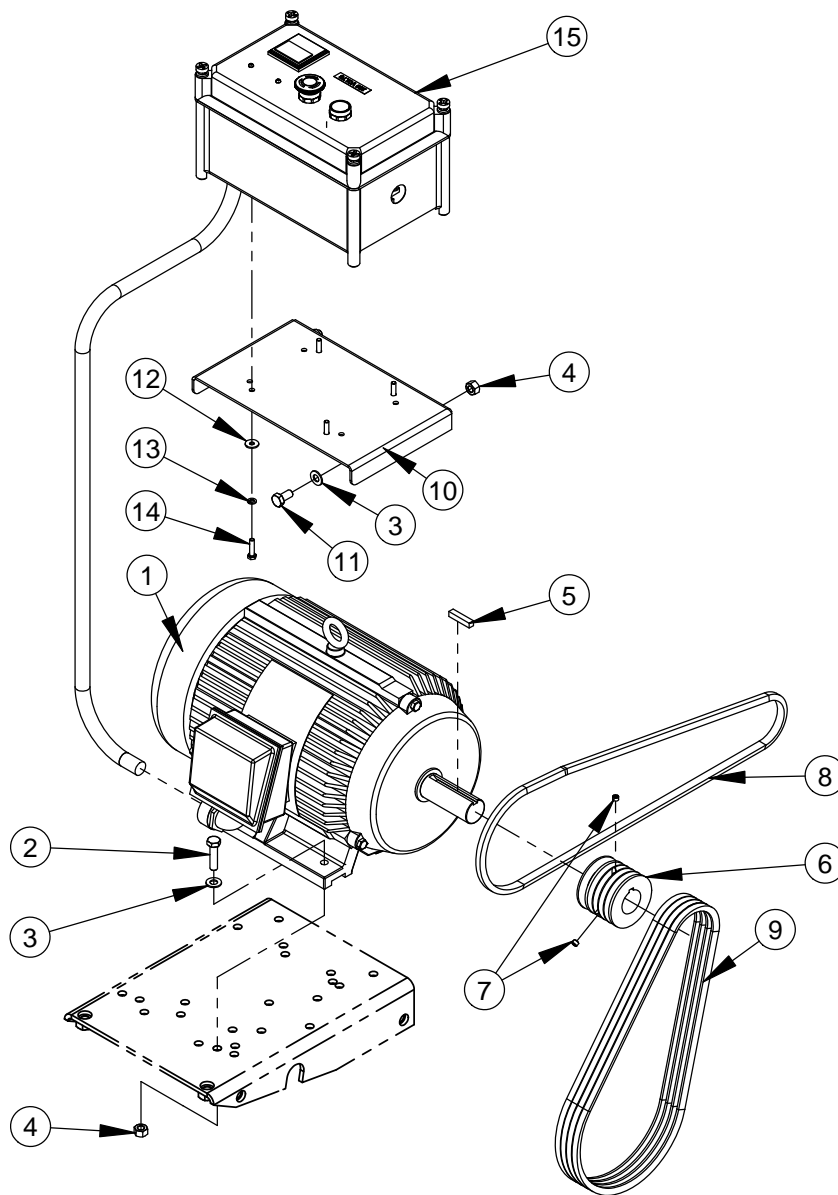

ITEM	PART NO.	QTY.	DESCRIPTION
1	2600202	1	Electric Motor, 15HP-3PH, 230/460V, Leeson
2	2900316	4	Cap Screw, Hex Hd., M10-1.5 x 40mm
3	2900014	6	Flat Washer, 3/8" SAE
4	2900304	6	Lock Nut, M10-1.5 Nylon Insert
5	6048046	1	Key, 5/16" Sq. x 1-1/2"
6	6047913	1	Sheave, 3" x 1-3/8" Bore
7	2900036	2	Set Screw, Soc. Hd., 5/16-18 x 1/4"
8	2500849	1	V-Belt, 4L-500
9	2500792	4	V-Belt, 3VX400
10	6047950	1	Starter Box Platform
11	2900314	2	Cap Screw, Hex Hd., M10-1.5 x 20mm
12	2901359	4	Fender Washer, M6
13	2900765	4	Lock Washer, M6 Split
14	2900311	4	Cap Screw, Hex Hd., M6-1.0 x 25mm
15	6004896	1	Starter Box Assembly, 3-Phase, 220-240V

15HP-460V Electric Motor Assembly #6047713

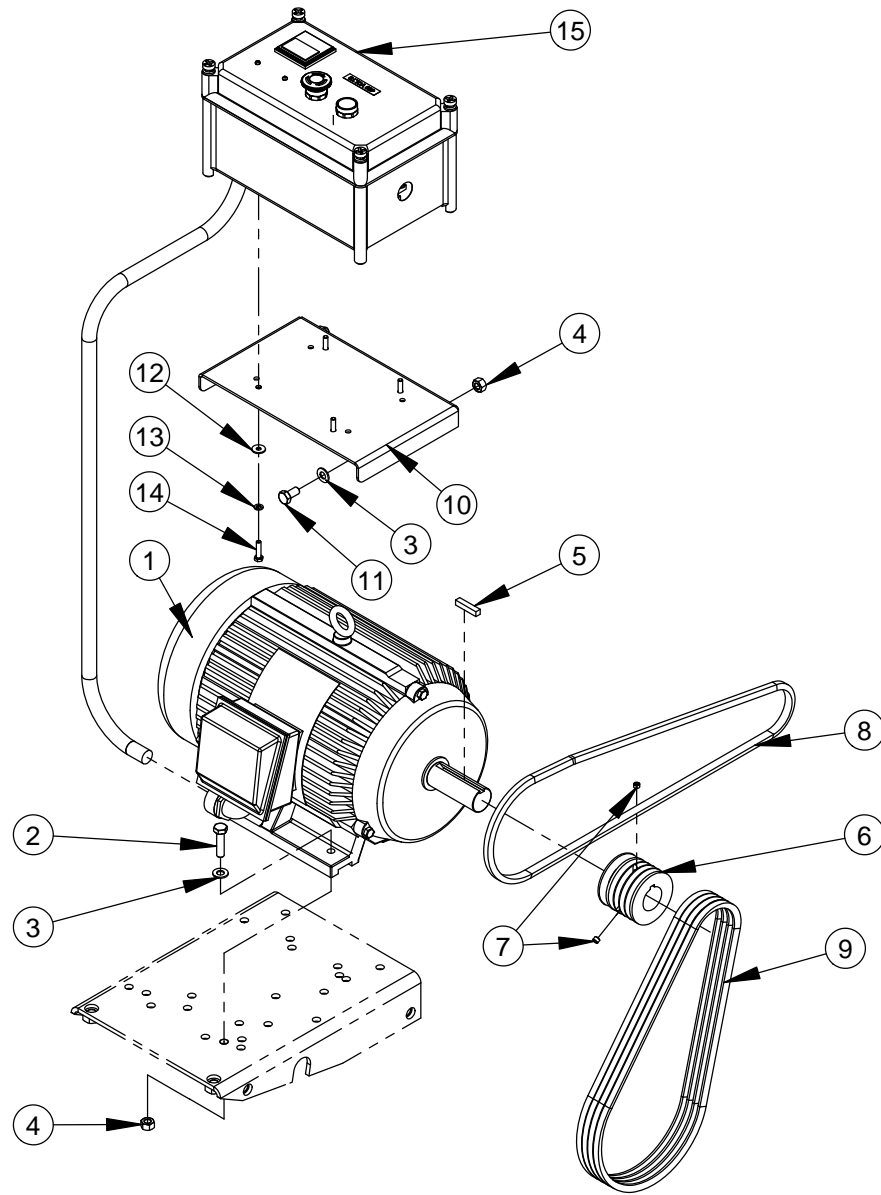

ITEM	PART NO.	QTY.	DESCRIPTION
1	2600202	1	Electric Motor, 15HP-3PH, 230/460V, Leeson
2	2900316	4	Cap Screw, Hex Hd., M10-1.5 x 40mm
3	2900014	6	Flat Washer, 3/8" SAE
4	2900304	6	Lock Nut, M10-1.5 Nylon Insert
5	6048046	1	Key, 5/16" Sq. x 1-1/2"
6	6047913	1	Sheave, 3" x 1-3/8" Bore
7	2900036	2	Set Screw, Soc. Hd., 5/16-18 x 1/4"
8	2500849	1	V-Belt, 4L-500
9	2500792	4	V-Belt, 3VX400
10	6047950	1	Starter Box Platform
11	2900314	2	Cap Screw, Hex Hd., M10-1.5 x 20mm
12	2901359	4	Fender Washer, M6
13	2900765	4	Lock Washer, M6 Split
14	2900311	4	Cap Screw, Hex Hd., M6-1.0 x 25mm
15	6004899	1	Starter Box Assembly, 3-Phase, 415-480V

15HP-575V Electric Motor Assembly #6047714

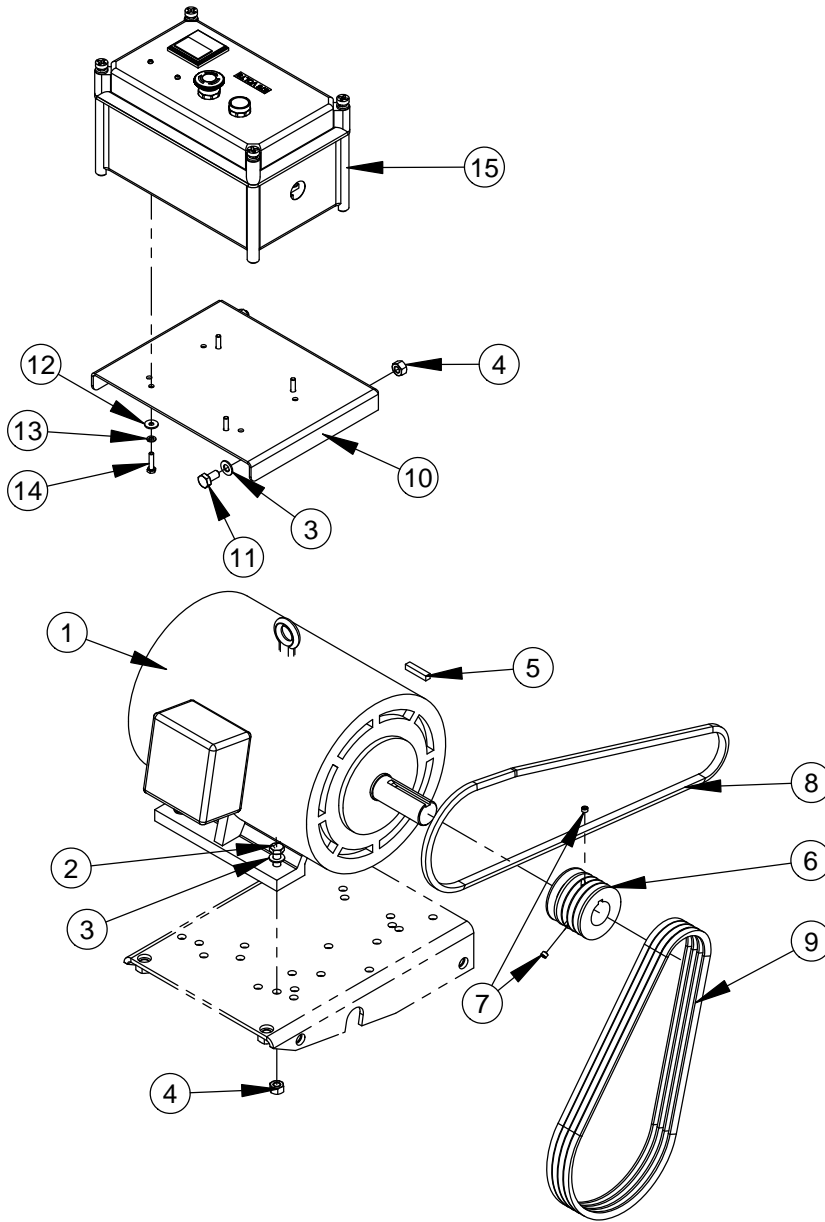

ITEM	PART NO.	QTY.	DESCRIPTION
1	2601673	1	Electric Motor, 15 HP, 575V, ODP
2	2900316	4	Cap Screw, Hex Hd., M10-1.5 x 40mm
3	2900014	6	Flat Washer, 3/8" SAE
4	2900304	6	Lock Nut, M10-1.5 Nylon Insert
5	6048046	1	Key, 5/16" Sq. x 1-1/2"
6	6047913	1	Sheave, 3" x 1-3/8" Bore
7	2900036	2	Set Screw, Soc. Hd., 5/16-18 x 1/4"
8	2500849	1	V-Belt, 4L-500
9	2500792	4	V-Belt, 3VX400
10	6047950	1	Starter Box Platform
11	2900314	2	Cap Screw, Hex Hd., M10-1.5 x 20mm
12	2901359	4	Fender Washer, M6
13	2900765	4	Lock Washer, M6 Split
14	2900311	4	Cap Screw, Hex Hd., M6-1.0 x 25mm
15	6004900	1	Starter Box Assembly, 3-Phase, 550-600V

STARTER BOX ASSEMBLY, 3-PHASE, 220-240V
#6004896

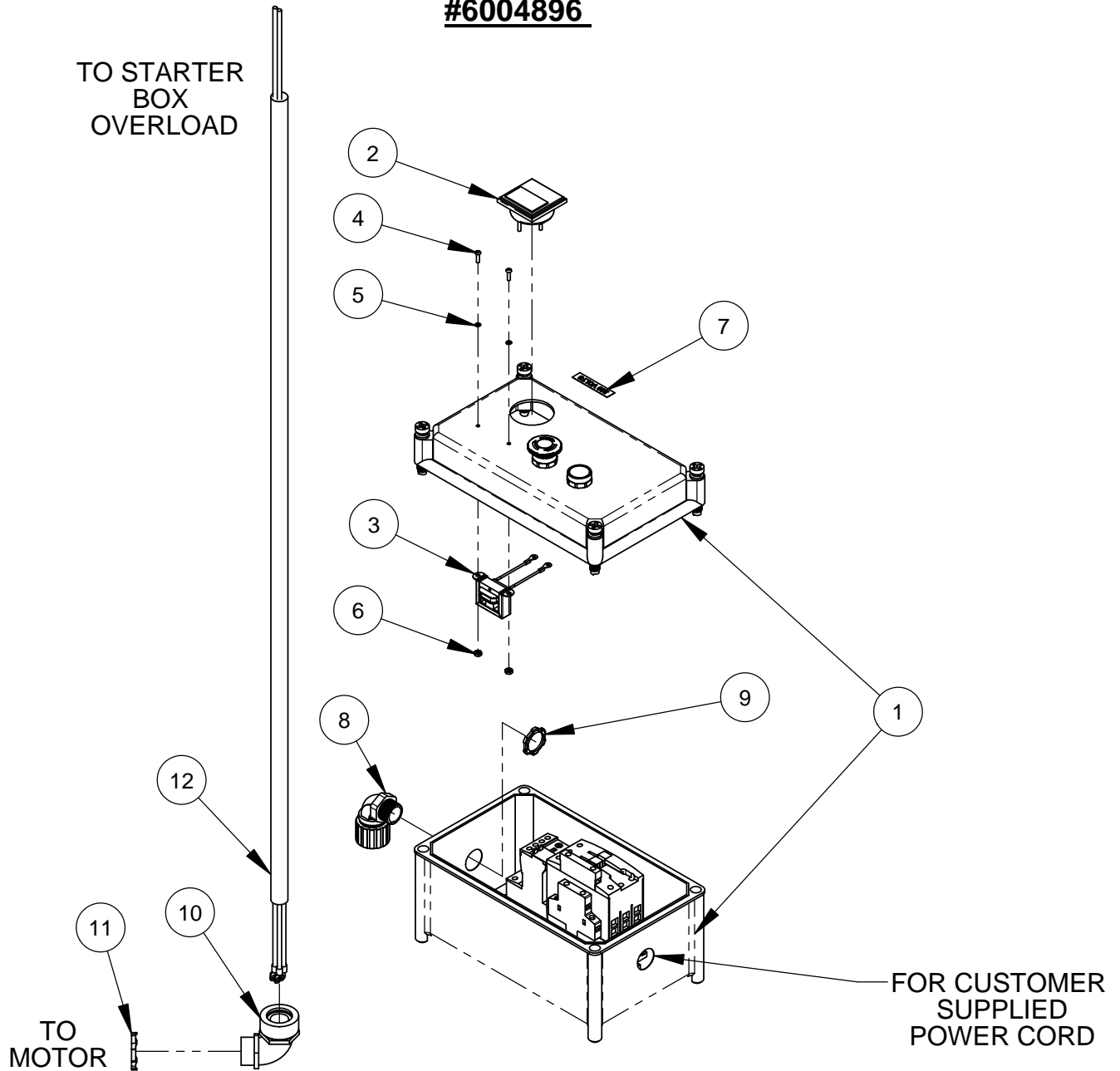

ITEM	PART NO.	QTY.	DESCRIPTION
1	2804008	1	Starter Box, 220-240V
2	2800253	1	Amp Meter w/ Bracket, 0-40 AC
3	2800085	1	AC Current Transformer
4	2900090	2	Machine Screw, Rd. Hd., #6-32 x 1/2"
5	2900092	2	Lock Washer, #6 Split
6	2900091	2	Hex Nut, #6-32
7	1800810	1	Voltage Label, 230V
8	2801303	1	Connector, 3/4" Cord 90Deg, Plastic
9	2801304	1	Lock Nut, 3/4"
10	2800339	1	Cord Grip, To 7/8", 90 Deg.
11	2800193	1	Lock Nut, 1"
12	6040304	1	Cable Assy., 8 Ga., 4 Wire x 54"

STARTER BOX ASSEMBLY, 3-PHASE, 415-480V
#6004899

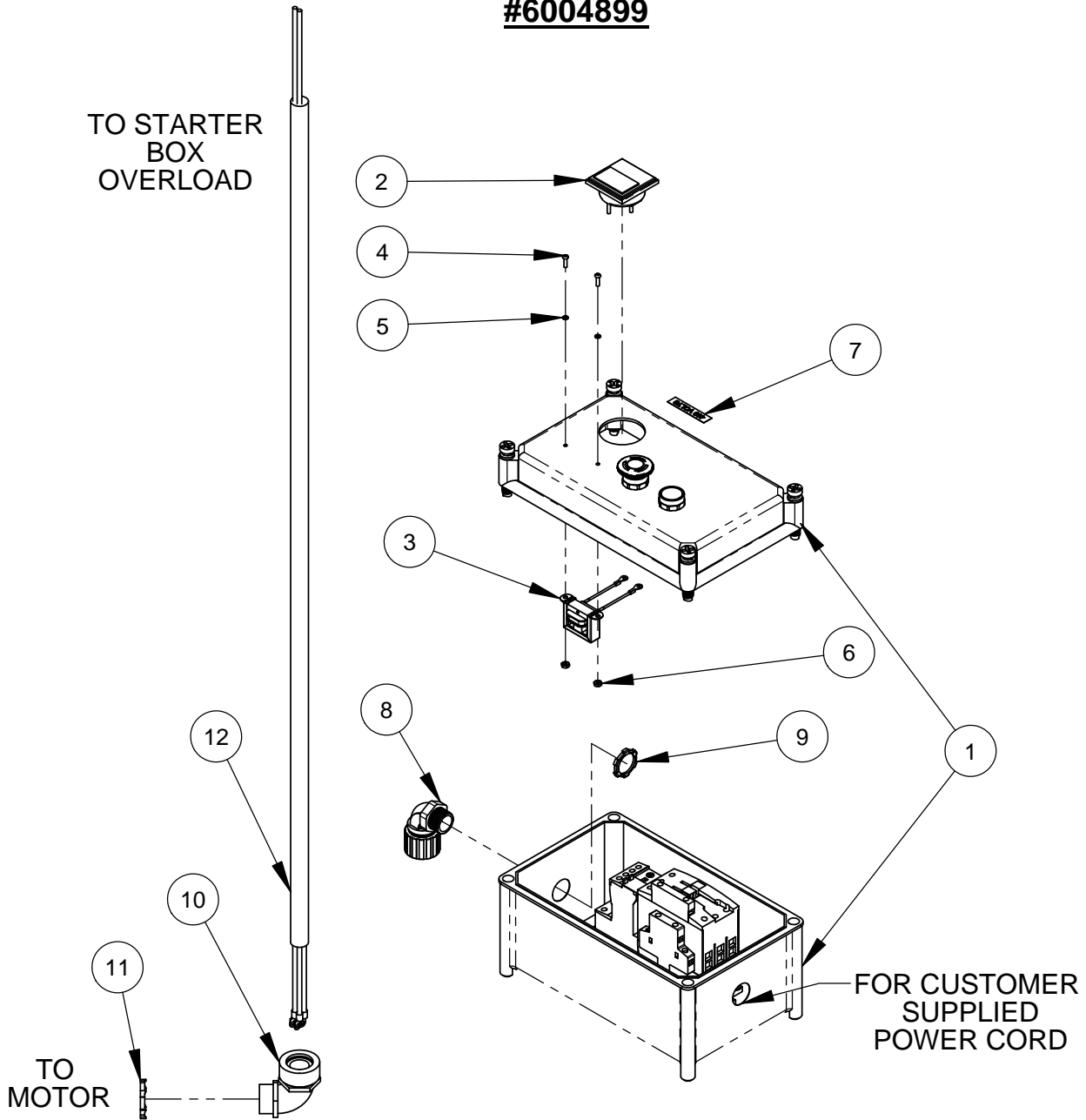

ITEM	PART NO.	QTY.	DESCRIPTION
1	2804007	1	Starter Box, 415-480V
2	2800252	1	Amp Meter, 0-20 AC
3	2800085	1	AC Current Transformer
4	2900090	2	Machine Screw, Rd. Hd., #6-32 x 1/2"
5	2900092	2	Lock Washer, #6 Split
6	2900091	2	Hex Nut, #6-32
7	1800811	1	Voltage Label, 460V
8	2801303	1	Connector, 3/4" Cord 90Deg, Plastic
9	2801304	1	Lock Nut, 3/4"
10	2800339	1	Cord Grip, To 7/8", 90 Deg.
11	2800193	1	Lock Nut, 1"
12	6040304	1	Cable Assy., 8 Ga., 4 Wire x 54"

STARTER BOX ASSEMBLY, 3-PHASE, 550-600V
#6004900

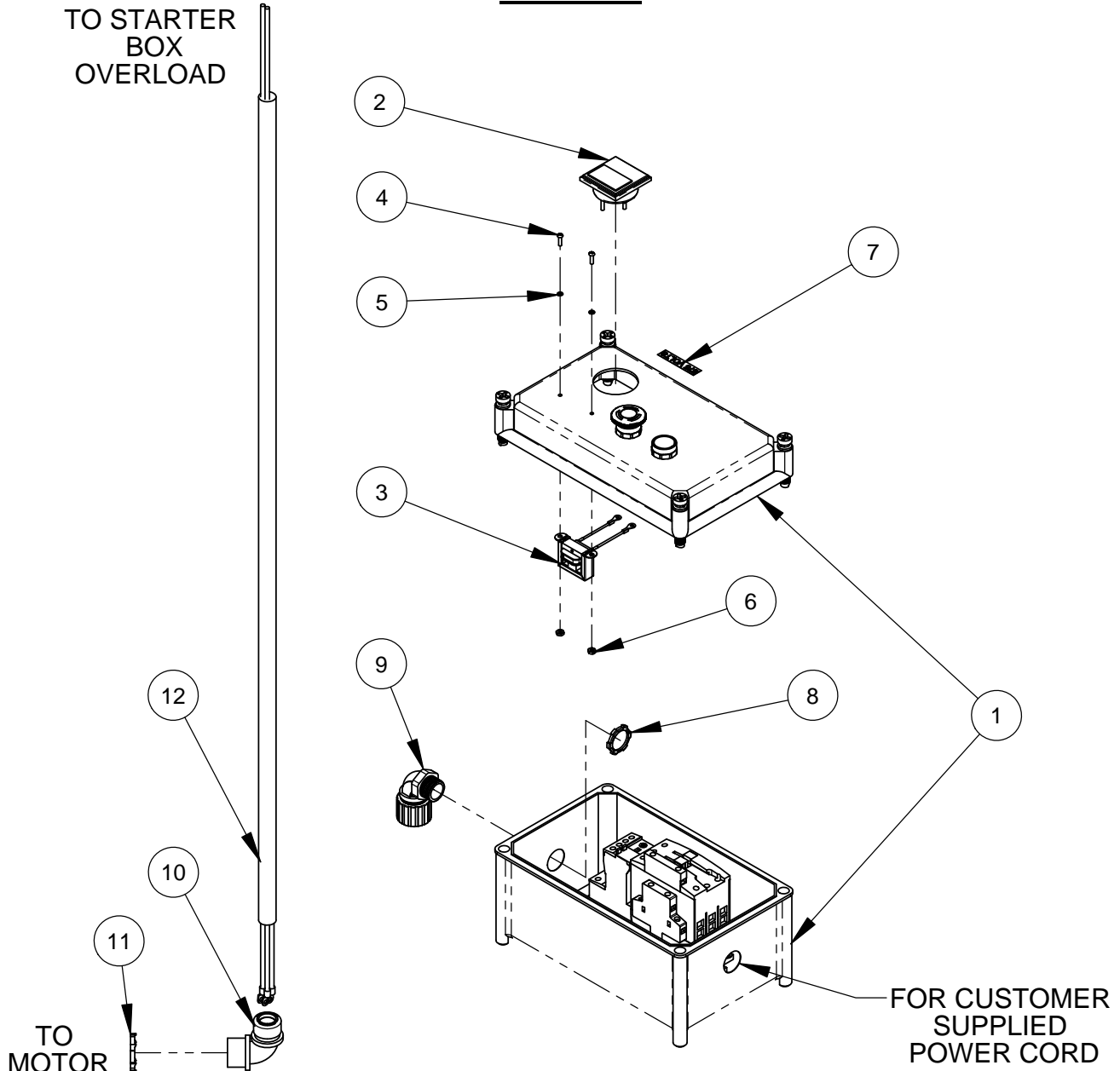

ITEM	PART NO.	QTY.	DESCRIPTION
1	2802061	1	Starter Box, 550-600V
2	2800252	1	Amp Meter, 0-20 AC
3	2800085	1	AC Current Transformer
4	2900090	2	Machine Screw, Rd. Hd., #6-32 x 1/2"
5	2900092	2	Lock Washer, #6 Split
6	2900091	2	Hex Nut, #6-32
7	1800812	1	Voltage Label, 575V
8	2801304	1	Lock Nut, 3/4"
9	2801303	1	Connector, 3/4" Cord 90Deg, Plastic
10	2800695	1	Cord Grip, 5/8-3/4", 90 Deg.
11	2800193	1	Lock Nut, 1"
12	6040304	1	Cable Assy., 8 Ga., 4 Wire x 54"

2804008 STARTER BOX, 220-240 VOLT

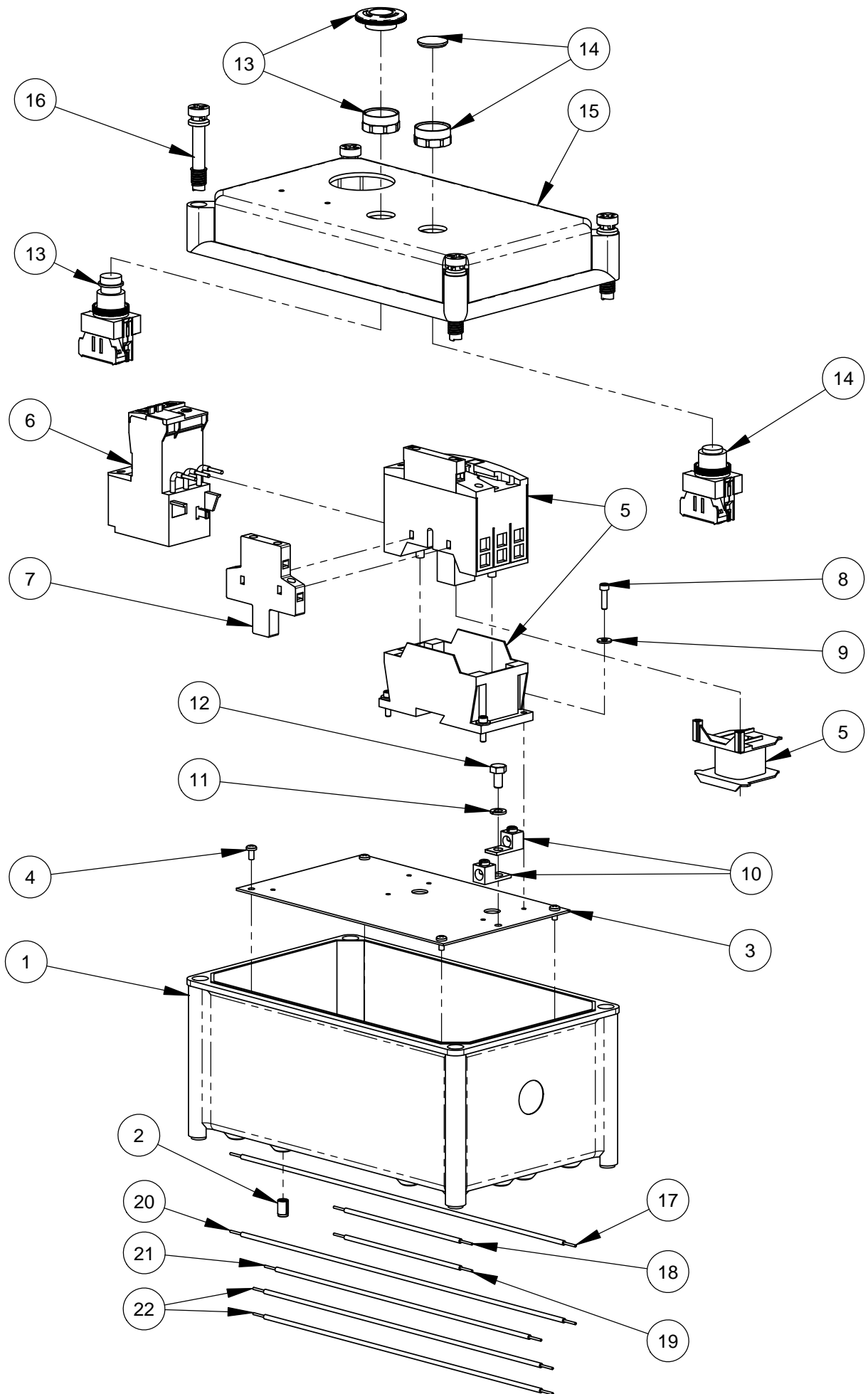

2804008 STARTER BOX, 220-240 VOLT

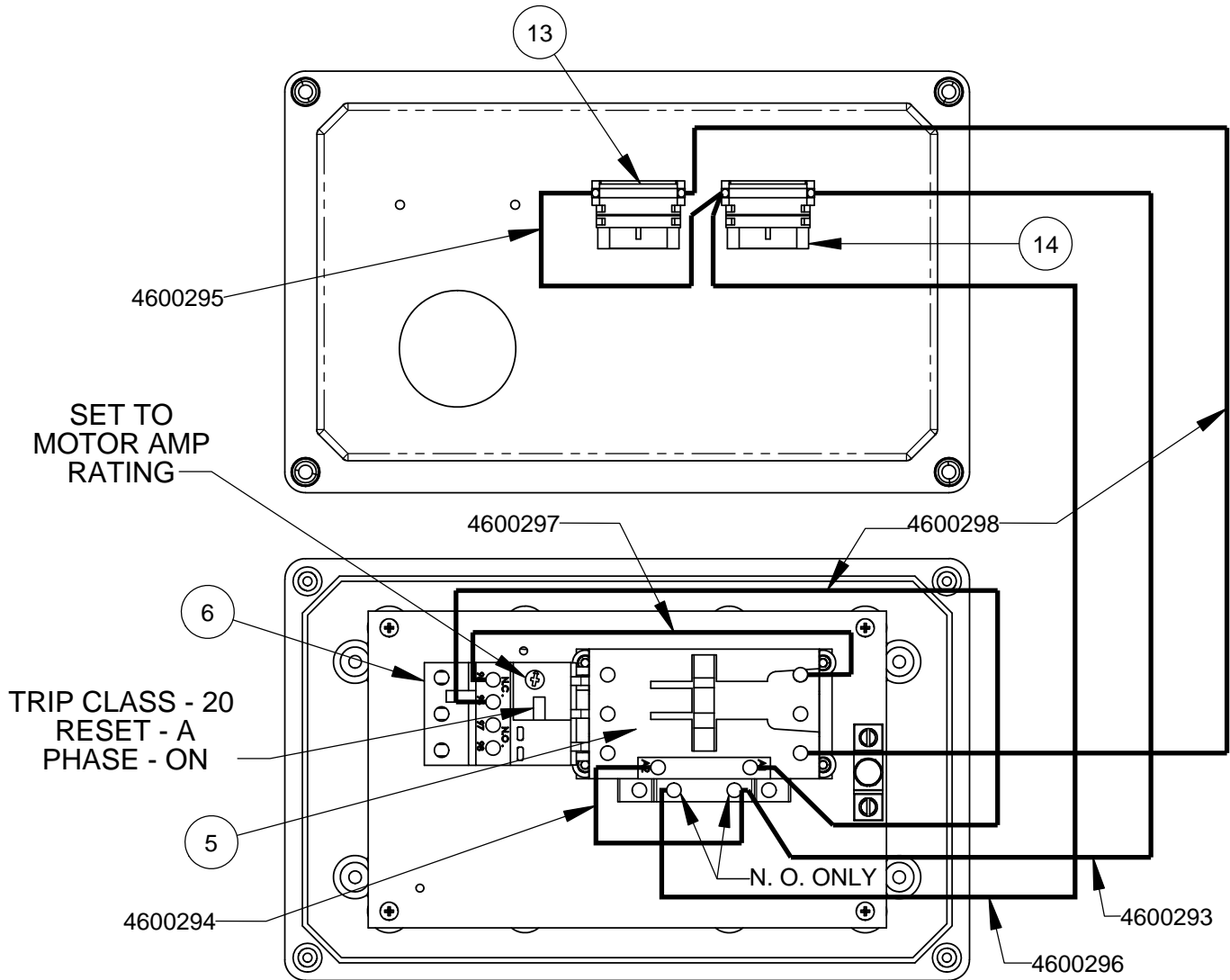

ITEM	PART NO.	QTY.	DESCRIPTION	ITEM	PART NO.	QTY.	DESCRIPTION
1	6040300D	1	Starter Box Base	12	2901891	1	Cap Screw, Hex Hd., 1/4-28 x 1/2"
2	2901588	4	M6-1.0 Threaded Insert	13	2801636	1	E-Stop Switch, 600V, NC
3	6040598	1	Sub-plate	14	2801639	1	Pushbutton, N.O., 600V
4	2900676	4	Machine Screw, Pan Hd., M4-0.7 x 8mm	15	6048293	1	Starter Box Cover
5	2801704	1	Contactor, 220-240V (includes coil)	16	2701414	4	Fastener, Electrical Box Top
	2801265	1	Replacement Coil, 220-240V	17	4600293	1	Wire, 14 Gage, Yellow, 15"
6	2801699	1	Overload Relay, 9-45 AMP	18	4600294	1	Wire, 14 Gage, Yellow, 6"
7	2801676	1	Auxiliary Contacts, 1NO-NC	19	4600295	1	Wire, 14 Gage, Black, 6"
8	2901827	4	Cap Screw, Soc. Hd., #8-32 x 5/8"	20	4600296	1	Wire, 14 Gage, Black, 15"
9	2901437	4	Flat Washer, #10	21	4600297	1	Wire, 14 Gage, Red, 12"
10	2800315	2	Grounding Lug	22	4600298	2	Wire, 14 Gage, Red, 13"
11	2900024	1	Lock Washer, 1/4" Split				

2804007 STARTER BOX, 415-480 VOLT

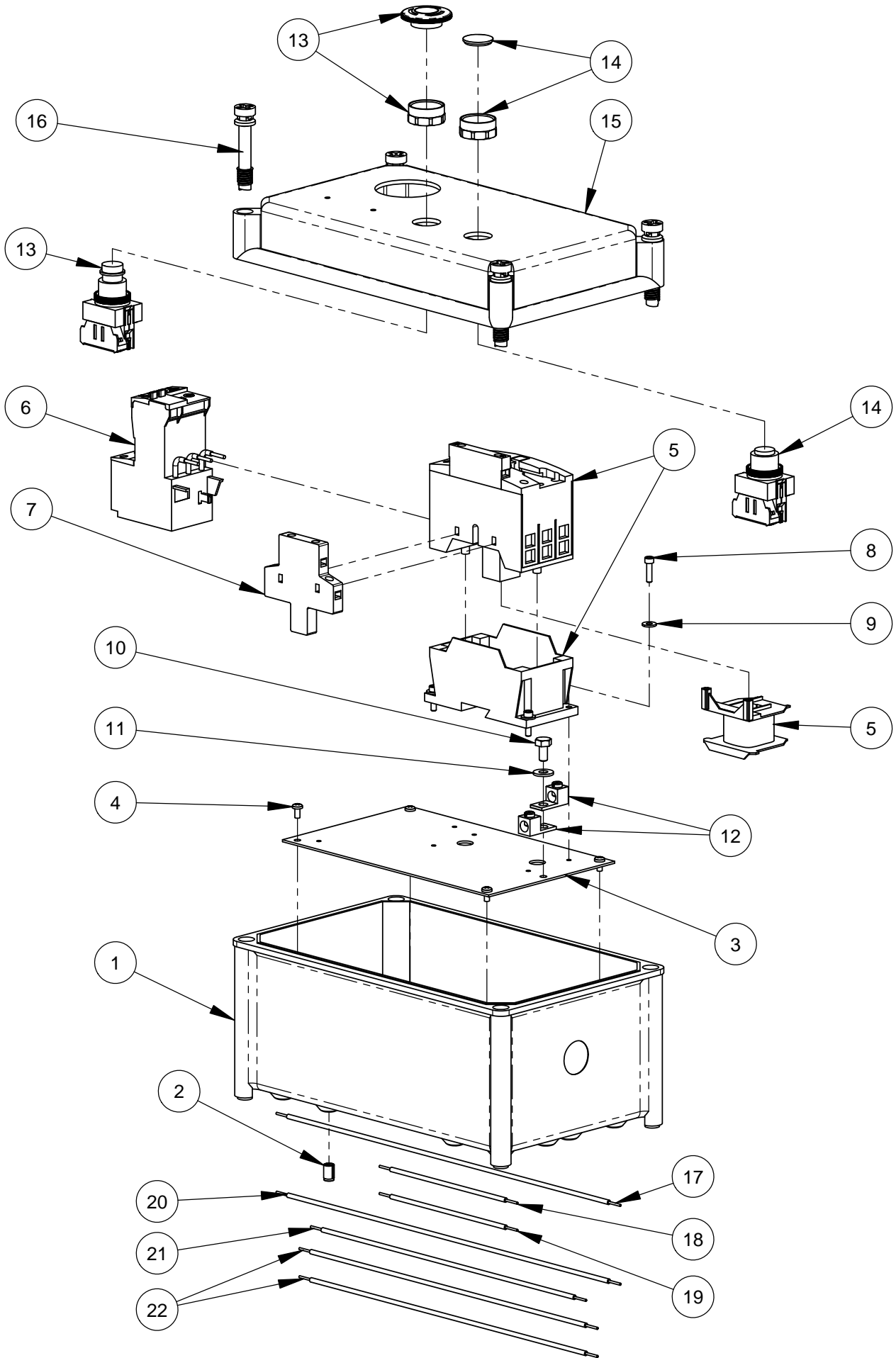

2804007 STARTER BOX, 415-480 VOLT

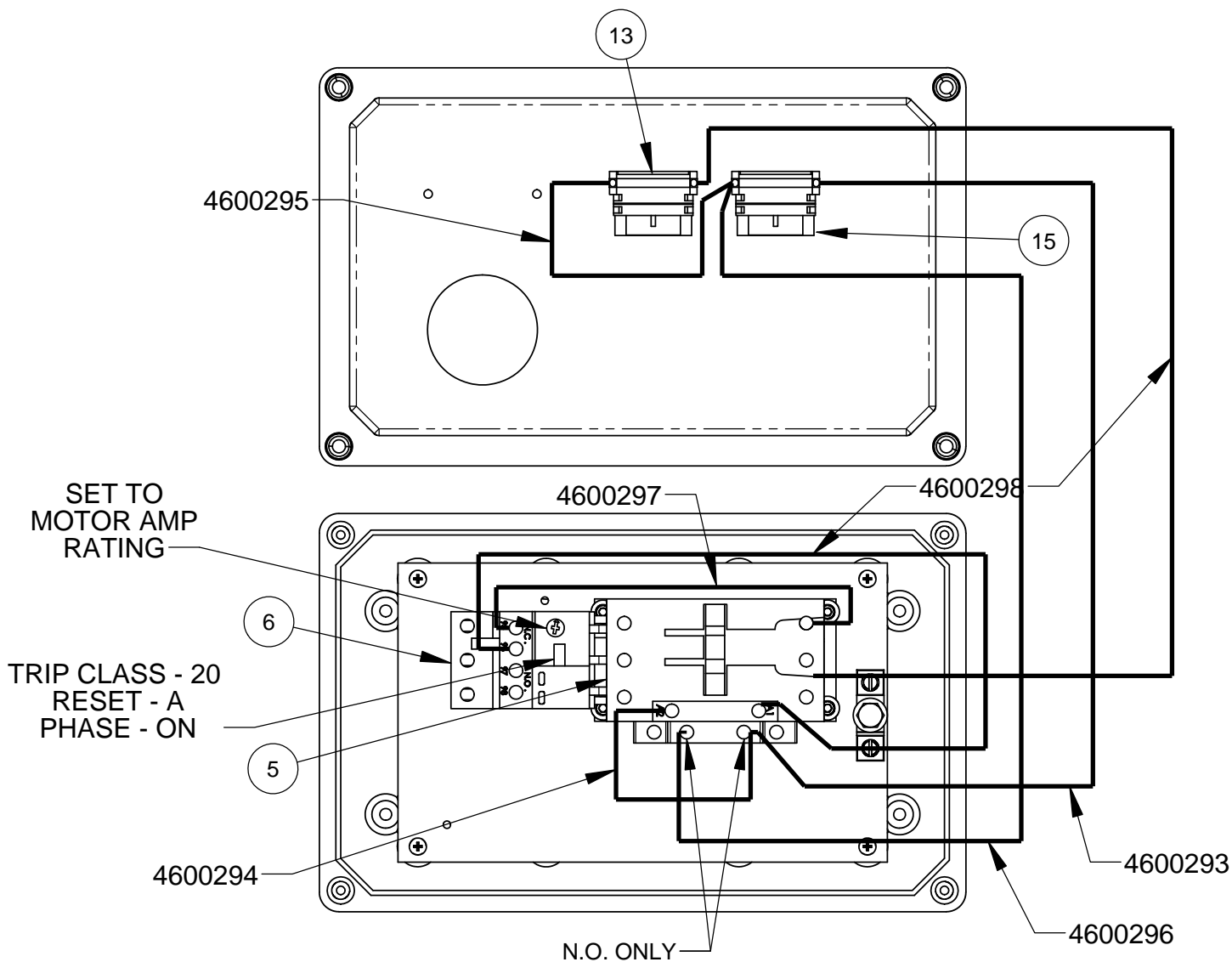

ITEM	PART NO.	QTY.	DESCRIPTION	ITEM	PART NO.	QTY.	DESCRIPTION
1	6040300D	1	Starter Box Base	12	2800315	2	Grounding Lug
2	2901588	4	M6-1.0 Threaded Insert	13	2801636	1	E-Stop Switch, 600V, NC
3	6040598	1	Sub-plate	14	2801639	1	Pushbutton, N.O., 600V
4	2900676	4	Machine Screw, Pan Hd., M4-0.7 x 8mm	15	6048293	1	Starter Box Cover
5	2801707	1	Contactor, 415-480V (Includes Coil)	16	2701414	4	Fastener, Electrical Box Top
	2801266	1	Replacement Coil, 415-480V	17	4600293	1	Wire, 14 Gage, Yellow, 15"
6	2801699	1	Overload Relay, 9-45 AMP	18	4600294	1	Wire, 14 Gage, Yellow, 6"
7	2801676	1	Auxiliary Contacts, 1NO-NC	19	4600295	1	Wire, 14 Gage, Black, 6"
8	2901827	4	Cap Screw, Soc. Hd., #8-32 x 5/8"	20	4600296	1	Wire, 14 Gage, Black, 15"
9	2901437	4	Flat Washer, #10	21	4600297	1	Wire, 14 Gage, Red, 12"
10	2901891	1	Cap Screw, Hex Hd., 1/4-28 x 1/2"	22	4600298	2	Wire, 14 Gage, Red, 13"
11	2900009	1	Flat Washer, 1/4" SAE				

2802061 STARTER BOX, 550-600 VOLT

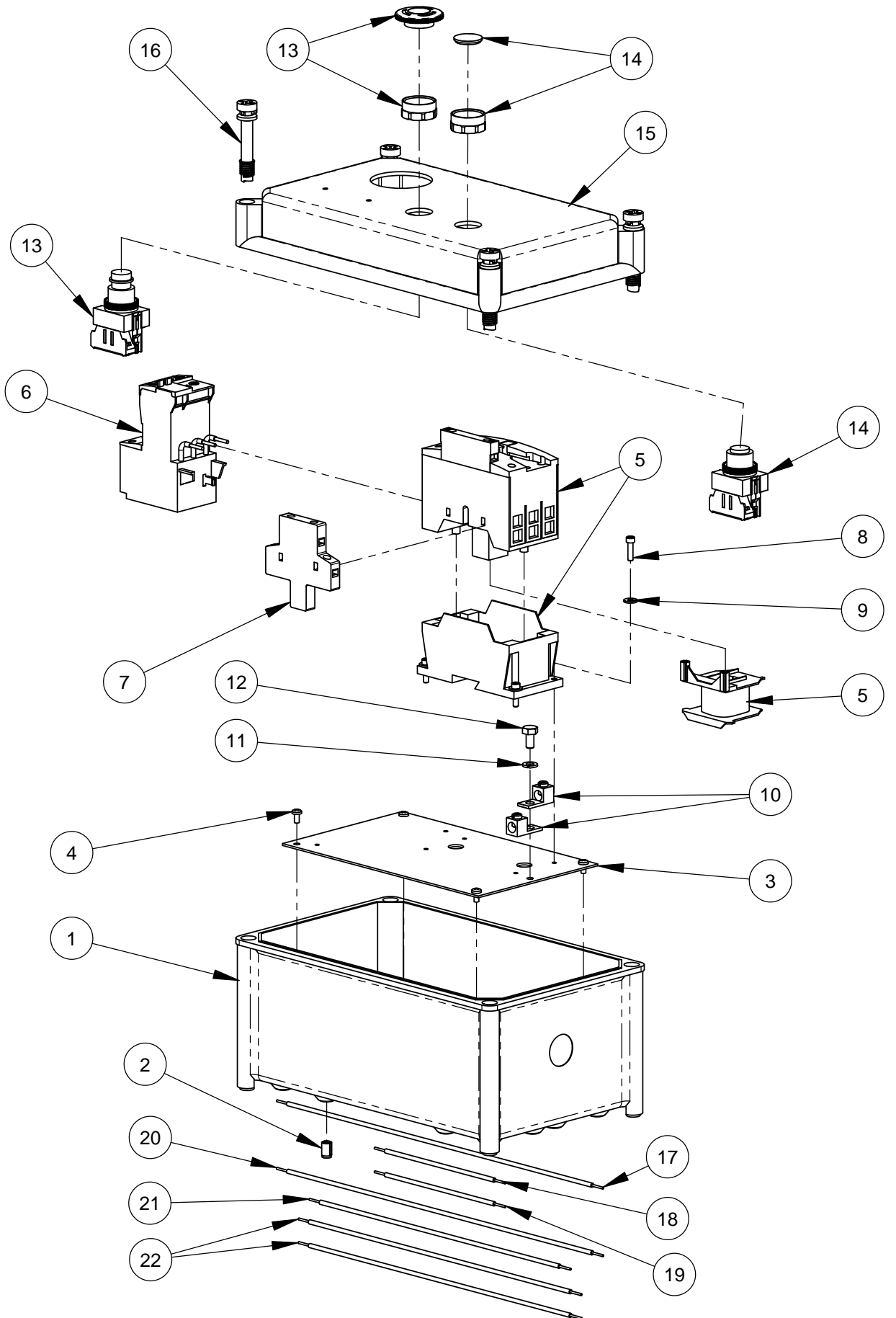

2802061 STARTER BOX, 550-600 VOLT

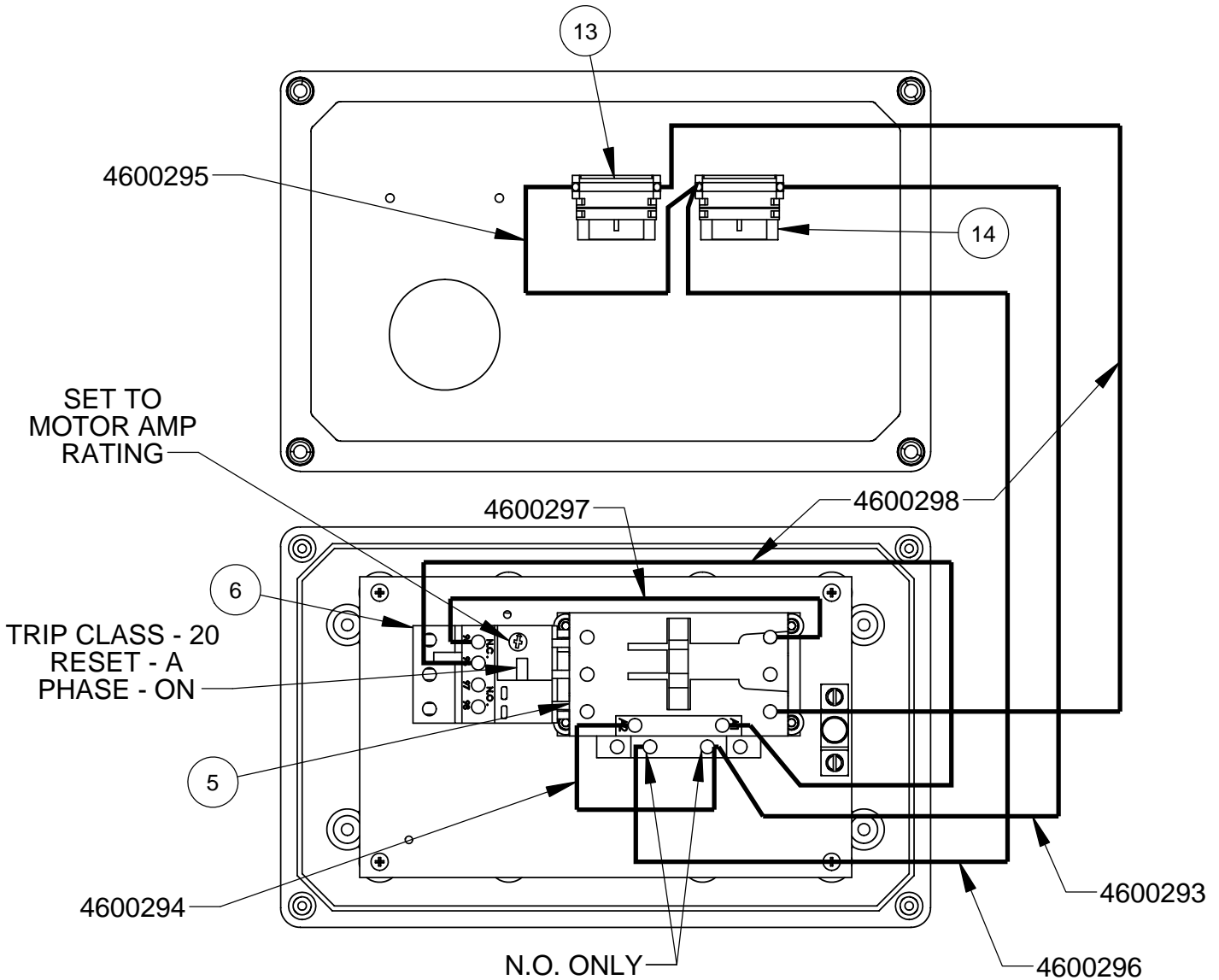

ITEM	PART NO.	QTY.	DESCRIPTION	ITEM	PART NO.	QTY.	DESCRIPTION
1	6040300D	1	Starter Box Base	11	2900024	1	Lock Washer, 1/4" Split
2	2901588	4	M6-1.0 Threaded Insert	12	2901891	1	Cap Screw, Hex Hd., 1/4-28 x 1/2"
3	6040598	1	Sub-plate	13	2801636	1	E-Stop Switch, 600V, NC
4	2900676	4	Machine Screw, Pan Hd., M4-0.7 x 8mm	14	2801639	1	Pushbutton, N.O., 600V
5	2801709	1	Contactor, 550-600V (includes coil)	15	6048293	1	Starter Box Cover
	2801267	1	Replacement Coil, 550-600V	16	2701414	4	Fastener, Electrical Box Top
6	2801699	1	Overload Relay, 9-45 AMP	17	4600293	1	Wire, 14 Gage, Yellow, 15"
7	2801676	1	Auxiliary Contacts, 1NO-NC	18	4600294	1	Wire, 14 Gage, Yellow, 6"
8	2901827	4	Cap Screw, Soc. Hd., #8-32 x 5/8"	19	4600295	1	Wire, 14 Gage, Black, 6"
9	2901437	4	Flat Washer, #10	20	4600296	1	Wire, 14 Gage, Black, 15"
10	2800315	2	Grounding Lug	21	4600297	1	Wire, 14 Gage, Red, 12"
				22	4600298	2	Wire, 14 Gage, Red, 13"

Hydraulic Motor Option for 14" & 16" Blade Guards #6049025

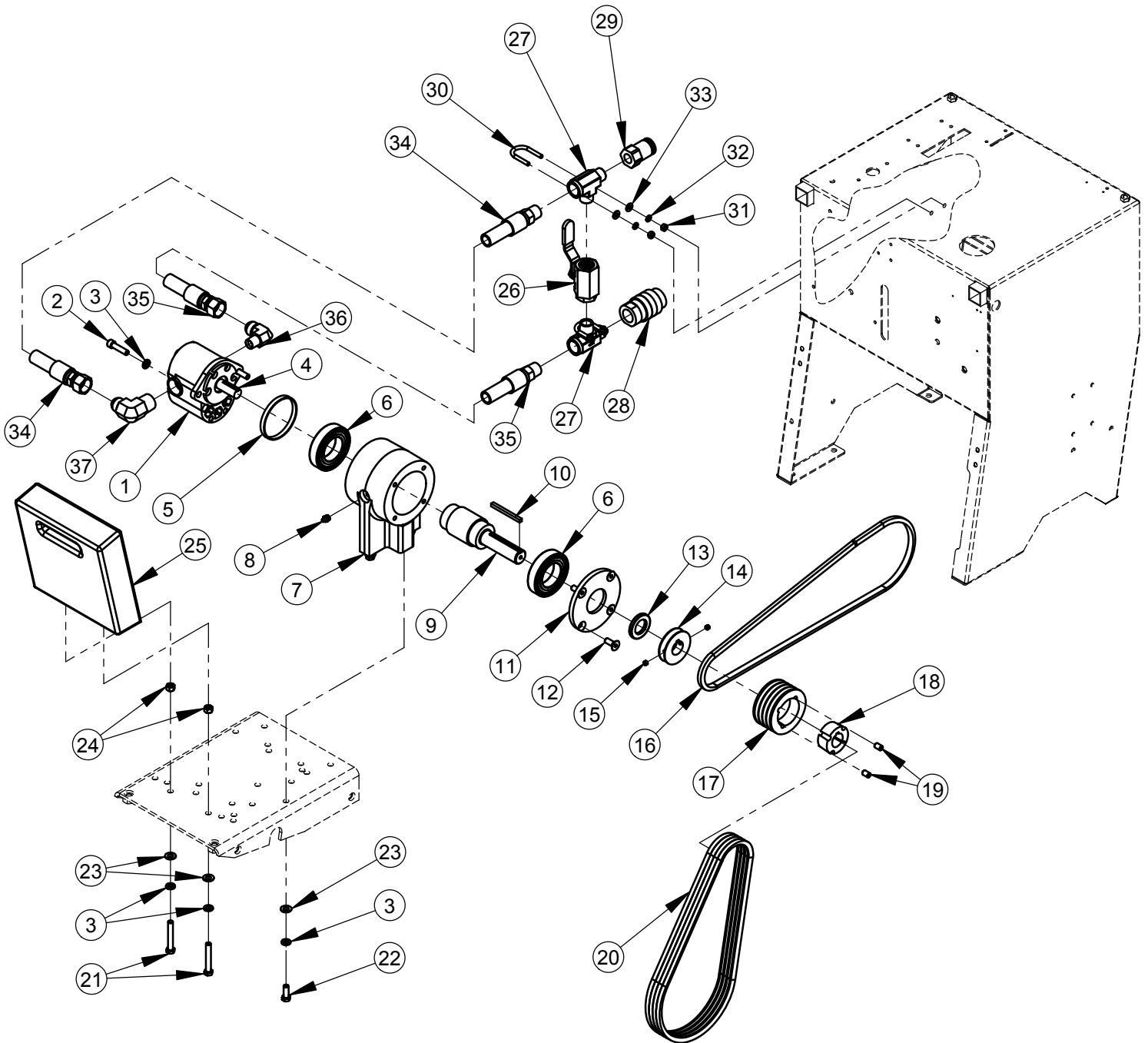

Hydraulic Motor Option for 14" & 16" Blade Guards #6049025

ITEM	PART NO.	QTY.	DESCRIPTION
1	2600064	1	Hydraulic Motor, Danfoss 1.94 cu. in.
2	2900357	2	Cap Screw, Soc. Hd., 3/8-16 x 1-1/2"
3	2900006	8	Lock Washer, 3/8" Split
4	6048229	1	Key, 3/16" Sq. x 1-1/4"
5	4699901	1	Shim For Hydraulic Spindle Shaft
6	2500686	2	Bearing, 50mm x 90mm x 20mm
7	6048115	1	Pillow Block
8	2900062	1	Grease Fitting, 1/8" NPT
9	6048116	1	Hydraulic Spindle Shaft
10	6047977	1	Key, 1/4" Sq. x 3"
11	6048117	1	Seal Plate
12	2900235	4	Cap Screw, Flat Hd., 3/8-16 x 1"
13	3200004	1	Seal, 1-1/8" x 2" x 1/4"
14	6048195	1	Pulley, 1-1/8" Bore
15	2900036	2	Set Screw, Soc. Hd., 5/16-18 x 1/4"
16	2500849	1	V-Belt, 4L-500
17	2500621	1	Sheave, 3V-3.65-4 Groove (1610)
18	2500031	1	Taper Bushing, 1-1/8" w/Set Screws
19	2900484	2	Set Screw, Soc. Hd., 3/8-16 x 5/8"
20	2500792	4	V-Belt, 3VX400
21	2900521	2	Tap Bolt, Hex Hd., 3/8-16 x 2-1/2"
22	2900005	4	Cap Screw, Hex Hd., 3/8-16 x 1"
23	2900014	6	Flat Washer, 3/8" SAE
24	2900033	2	Hex Nut, 3/8-16
25	6048255	1	Saw Weight
26	3200005	1	Ball Valve, 3/4" Pipe
27	3200083	2	Tee, 3/4" Pipe Run
28	3200100	1	Coupler, 3/4" Quick Disconnect
29	3200101	1	Nipple, 3/4" Quick Disconnect
30	2900369	2	U-Bolt, 3/4" Pipe
31	2900125	4	Hex Nut, 1/4-20
32	2900024	4	Lock Washer, 1/4" Split
33	2900009	4	Flat Washer, 1/4" SAE
34	6048214	1	Hose, 3/4" x 34" Return
35	6048136	1	Hose, 3/4" x 28" Pressure
36	3200110	1	Elbow, 1/2" M. Pipe to 3/4" M. JIC
37	3200111	1	Elbow, 1" M. Pipe to 3/4" M. JIC

Hydraulic Motor Option for 26" Blade Guards #6049026

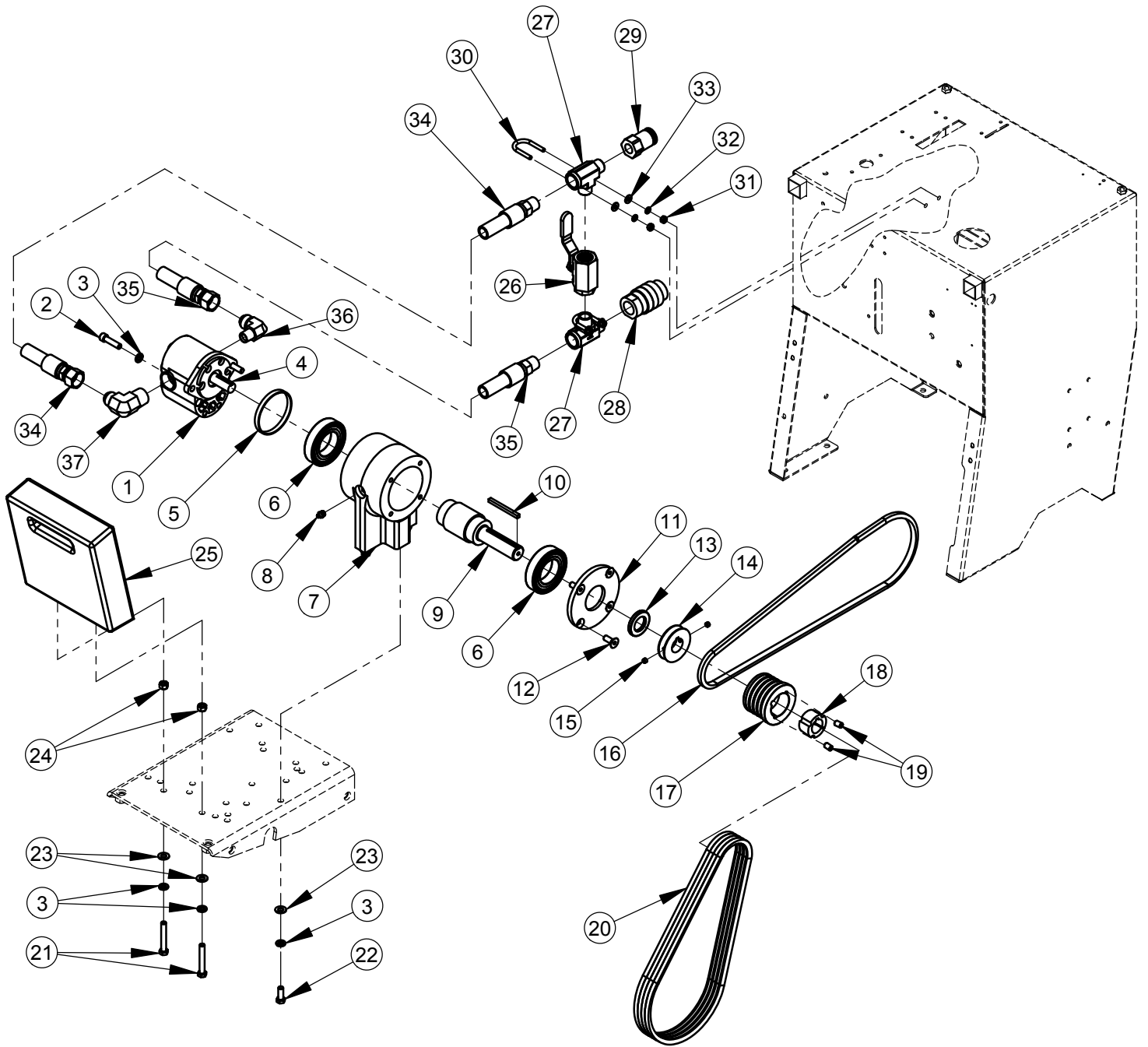

Hydraulic Motor Option for 26" Blade Guards #6049026

ITEM	PART NO.	QTY.	DESCRIPTION
1	2600064	1	Hydraulic Motor, Danfoss 1.94 cu. in.
2	2900357	2	Cap Screw, Soc. Hd., 3/8-16 x 1-1/2"
3	2900006	8	Lock Washer, 3/8" Split
4	6048229	1	Key, 3/16" Sq. x 1-1/4"
5	4699901	1	Shim For Hydraulic Spindle Shaft
6	2500686	2	Bearing, 50mm x 90mm x 20mm
7	6048115	1	Pillow Block
8	2900062	1	Grease Fitting, 1/8" NPT
9	6048116	1	Hydraulic Spindle Shaft
10	6047977	1	Key, 1/4" Sq. x 3"
11	6048117	1	Seal Plate
12	2900235	4	Cap Screw, Flat Hd., 3/8-16 x 1"
13	3200004	1	Seal, 1-1/8" x 2" x 1/4"
14	6048195	1	Pulley, 1-1/8" Bore
15	2900036	2	Set Screw, Soc. Hd., 5/16-18 x 1/4"
16	2500849	1	V-Belt, 4L-500
17	2500817	1	Sheave, 3.00-3V-4 Groove
18	2500029	1	Taper Bushing, 1-1/8" with Set Screws
19	2900484	2	Set Screw, Soc. Hd., 3/8-16 x 5/8"
20	2500792	4	V-Belt, 3VX400
21	2900521	2	Tap Bolt, Hex Hd., 3/8-16 x 2-1/2"
22	2900005	4	Cap Screw, Hex Hd., 3/8-16 x 1"
23	2900014	6	Flat Washer, 3/8" SAE
24	2900033	2	Hex Nut, 3/8-16
25	6048255	1	Saw Weight
26	3200005	1	Ball Valve, 3/4" Pipe
27	3200083	2	Tee, 3/4" Pipe Run
28	3200100	1	Coupler, 3/4" Quick Disconnect
29	3200101	1	Nipple, 3/4" Quick Disconnect
30	2900369	2	U-Bolt, 3/4" Pipe
31	2900125	4	Hex Nut, 1/4-20
32	2900024	4	Lock Washer, 1/4" Split
33	2900009	4	Flat Washer, 1/4" SAE
34	6048214	1	Hose, 3/4" x 34" Return
35	6048136	1	Hose, 3/4" x 28" Pressure
36	3200110	1	Elbow, 1/2" M. Pipe to 3/4" M. JIC
37	3200111	1	Elbow, 1" M. Pipe to 3/4" M. JIC

14" Blade Guard Assembly #6010950

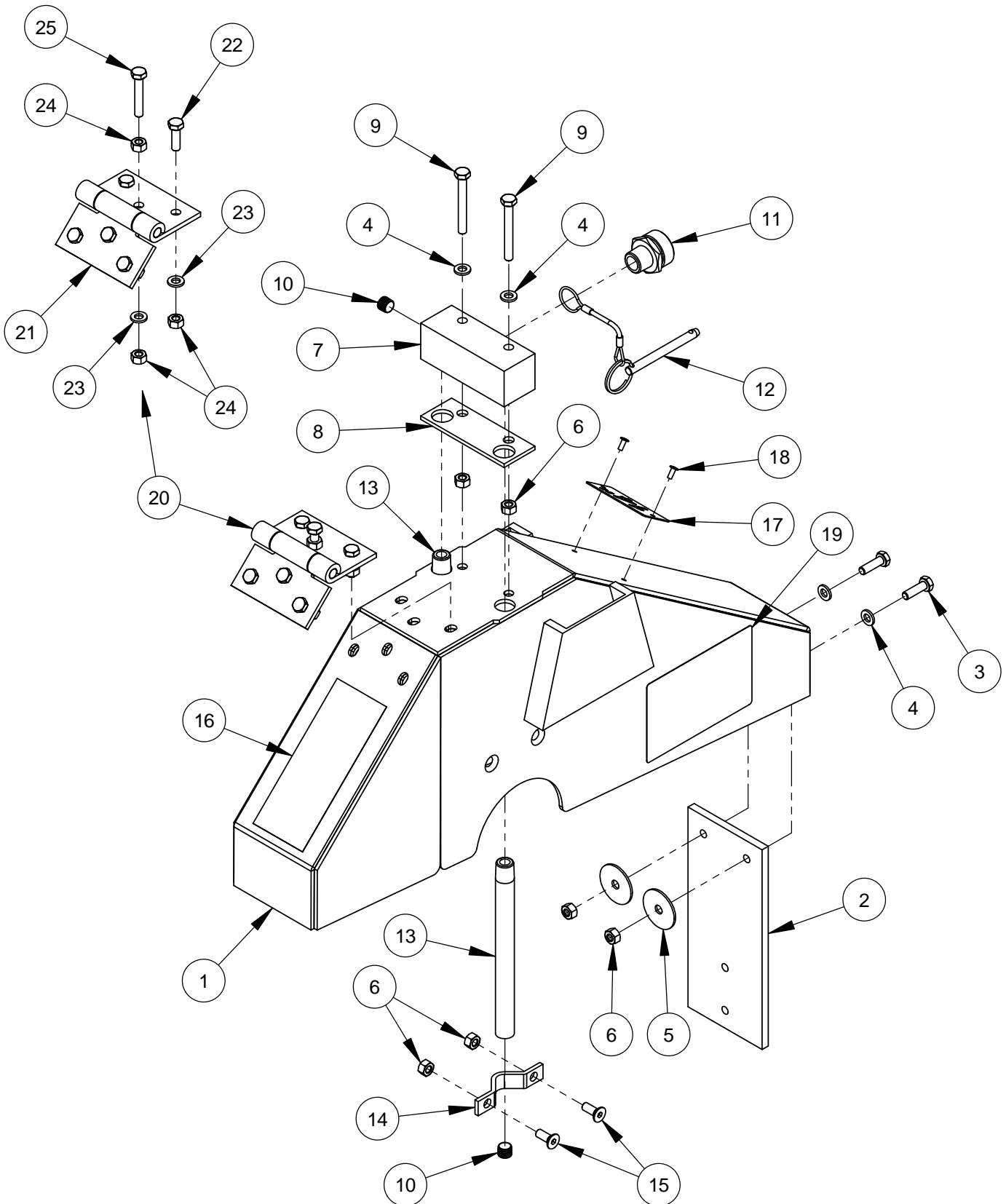

14" Blade Guard Assembly #6010950

ITEM	PART NO.	QTY.	DESCRIPTION
1	6010601	1	14" Blade Guard Front & Rear Only
2	6010081	1	Splash Flap
3	2900310	2	Cap Screw, Hex Hd., M6-1.0 x 20mm
4	2901494	4	Flat Washer, M6
5	2900083	2	Fender Washer, 1/4" x 1-1/4"
6	2900302	8	Lock Nut, M6-1.0 Nylon Insert
7	6010261	1	Water Manifold
8	2500830	1	Water Manifold Gasket
9	2901355	2	Cap Screw, Hex Hd., M6-1.0 x 50mm
10	3200001	3	Plug, 1/8" NPT
11	3200002	1	Fitting, 3/8" M. Pipe to 3/4" M. Garden
12	2900278	1	Lanyard with Lock Pin
13	6048283	2	Water Tube for 14" Guard
14	6048155	2	Water Tube Clamp
15	2900308	4	Cap Screw, Flat Hd., M6-1.0 x 16mm
16	1800001	1	Warning Label
17	1801369A	1	Blade Guard Size Tag
18	2900287	2	Rivet, 1/8" Dia.
19	1802090	2	Label, Wedge Locking Washer
20	6048026	1	Hinge Assembly

ITEM	PART NO.	QTY.	DESCRIPTION
21	2500270	1	Blade Guard Hinge
22	2900310	5	Cap Screw, Hex Hd., M6-1.0 x 20mm
23	2901494	6	Flat Washer, M6
24	2900302	7	Lock Nut, M6-1.0 Nylon Insert
25	2900312	1	Cap Screw, Hex Hd., M6-1.0 x 35mm

20" Blade Guard Assembly #6010952

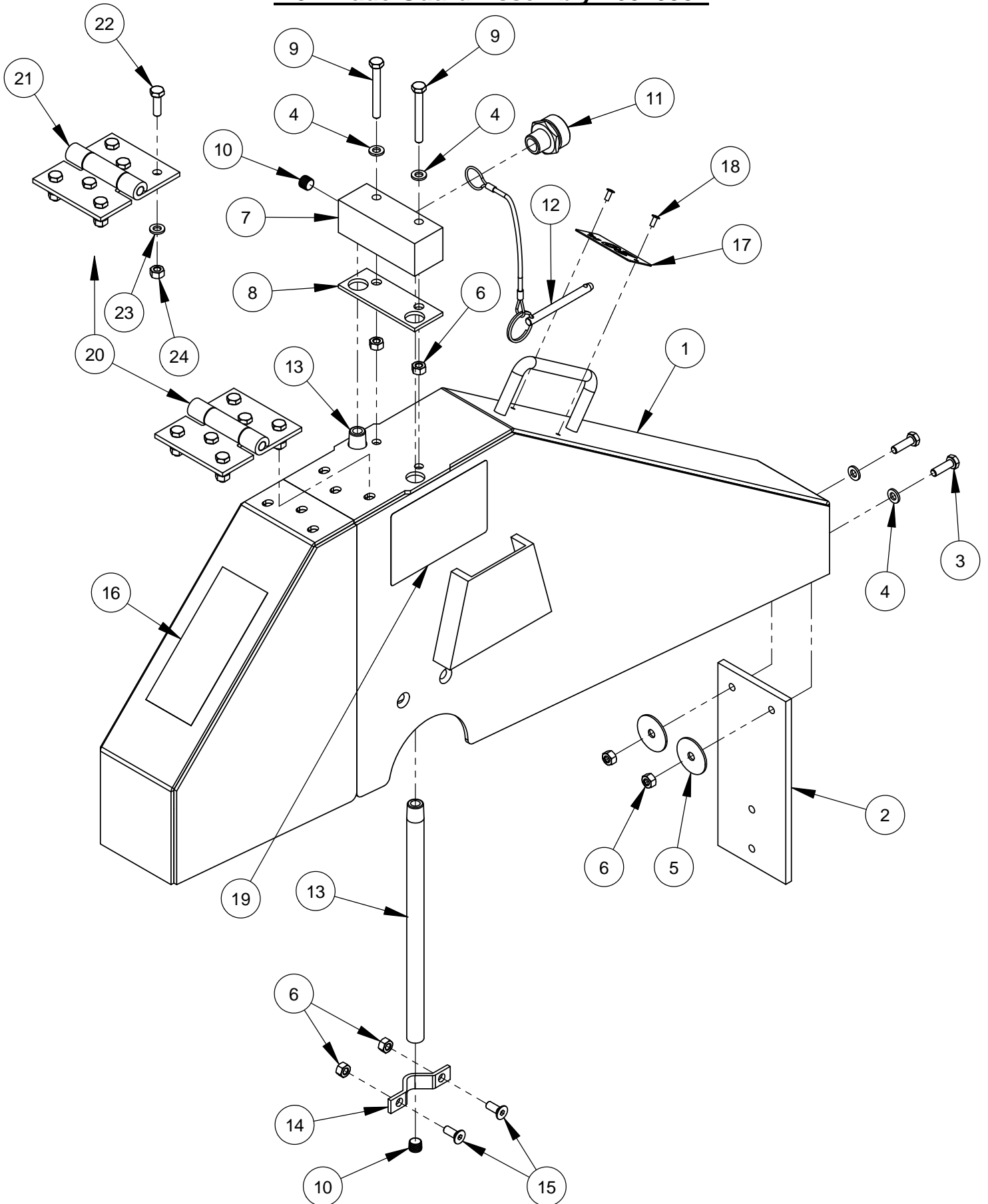

20" Blade Guard Assembly #6010952

ITEM	PART NO.	QTY.	DESCRIPTION
1	6010603	1	20" Blade Guard Front & Rear Only
2	6010081	1	Splash Flap
3	2900310	2	Cap Screw, Hex Hd., M6-1.0 x 20mm
4	2901494	4	Flat Washer, M6
5	2900083	2	Fender Washer, 1/4" x 1-1/4"
6	2900302	8	Lock Nut, M6-1.0 Nylon Insert
7	6010261	1	Water Manifold
8	2500830	1	Water Manifold Gasket
9	2901355	2	Cap Screw, Hex Hd., M6-1.0 x 50mm
10	3200001	3	Plug, 1/8" NPT
11	3200002	1	Fitting, 3/8" M. Pipe to 3/4" M. Garden
12	2900278	1	Lanyard with Lock Pin
13	6010085	2	Water Tube for 20" Guard
14	6048155	2	Water Tube Clamp
15	2900308	4	Cap Screw, Flat Hd., M6-1.0 x 16mm
16	1800001	1	Warning Label
17	1801369D	1	Blade Guard Size Tag
18	2900287	2	Rivet, 1/8" Dia.
19	1802090	2	Label, Wedge Locking Washer
20	6048027	1	Hinge Assembly

ITEM	PART NO.	QTY.	DESCRIPTION
21	2500270	1	Blade Guard Hinge
22	2900310	6	Cap Screw, Hex Hd., M6-1.0 x 20mm
23	2901494	6	Flat Washer, M6
24	2900302	6	Lock Nut, M6-1.0 Nylon Insert

26" Blade Guard Assembly #6010954

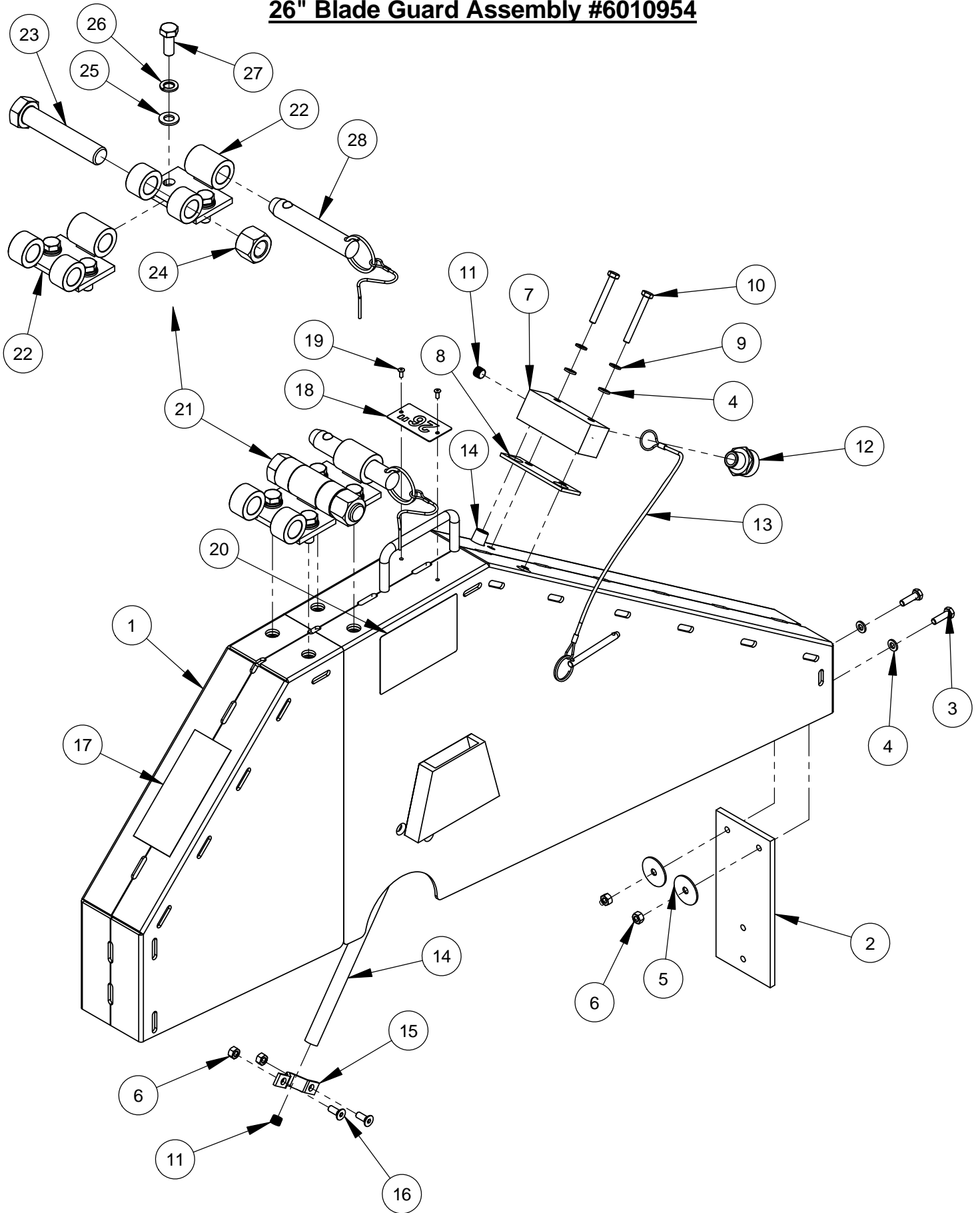

26" Blade Guard Assembly #6010954

ITEM	PART NO.	QTY.	DESCRIPTION
1	6010955	1	26" Blade Guard Front & Rear Only
2	6010081	1	Splash Flap
3	2900310	2	Cap Screw, Hex Hd., M6-1.0 x 20mm
4	2901494	4	Flat Washer, M6
5	2900083	2	Fender Washer, 1/4" x 1-1/4"
6	2900302	6	Lock Nut, M6-1.0 Nylon Insert
7	6010261	1	Water Manifold
8	2500830	1	Water Manifold Gasket
9	2900765	2	Lock Washer, M6 Split
10	2901355	2	Cap Screw, Hex Hd., M6-1.0 x 50mm
11	3200001	3	Plug, 1/8" NPT
12	3200002	1	Fitting, 3/8" M. Pipe to 3/4" M. Garden
13	2900279	1	Lanyard with Lock Pin
14	6010086	2	Water Tube for 26" Guard
15	6048155	2	Water Tube Clamp
16	2900308	4	Cap Screw, Flat Hd., M6-1.0 x 16mm
17	1800001	1	Warning Label
18	1801369F	1	Blade Guard Size Tag
19	2900287	2	Rivet, 1/8" Dia.
20	1802090	2	Label, Wedge Locking Washer
21	6010873	1	Universal Hinge Assembly

ITEM	PART NO.	QTY	DESCRIPTION
22	6010871	2	Hinge Weldment, Universal
23	2900479	1	Cap Screw, Hex Hd., 3/4-10 x 4"
24	2900467	1	Lock Nut, 3/4-10 Nylon
25	2901356	4	Flat Washer, M10
26	2900321	4	Lock Washer, M10 Split
27	2900333	4	Cap Screw, Hex Hd., M10-1.5 x 25mm
28	2503824	1	Detent Pin, 3/4" x 3" Grip

Electric Power Raise/Lower Assembly #6047967

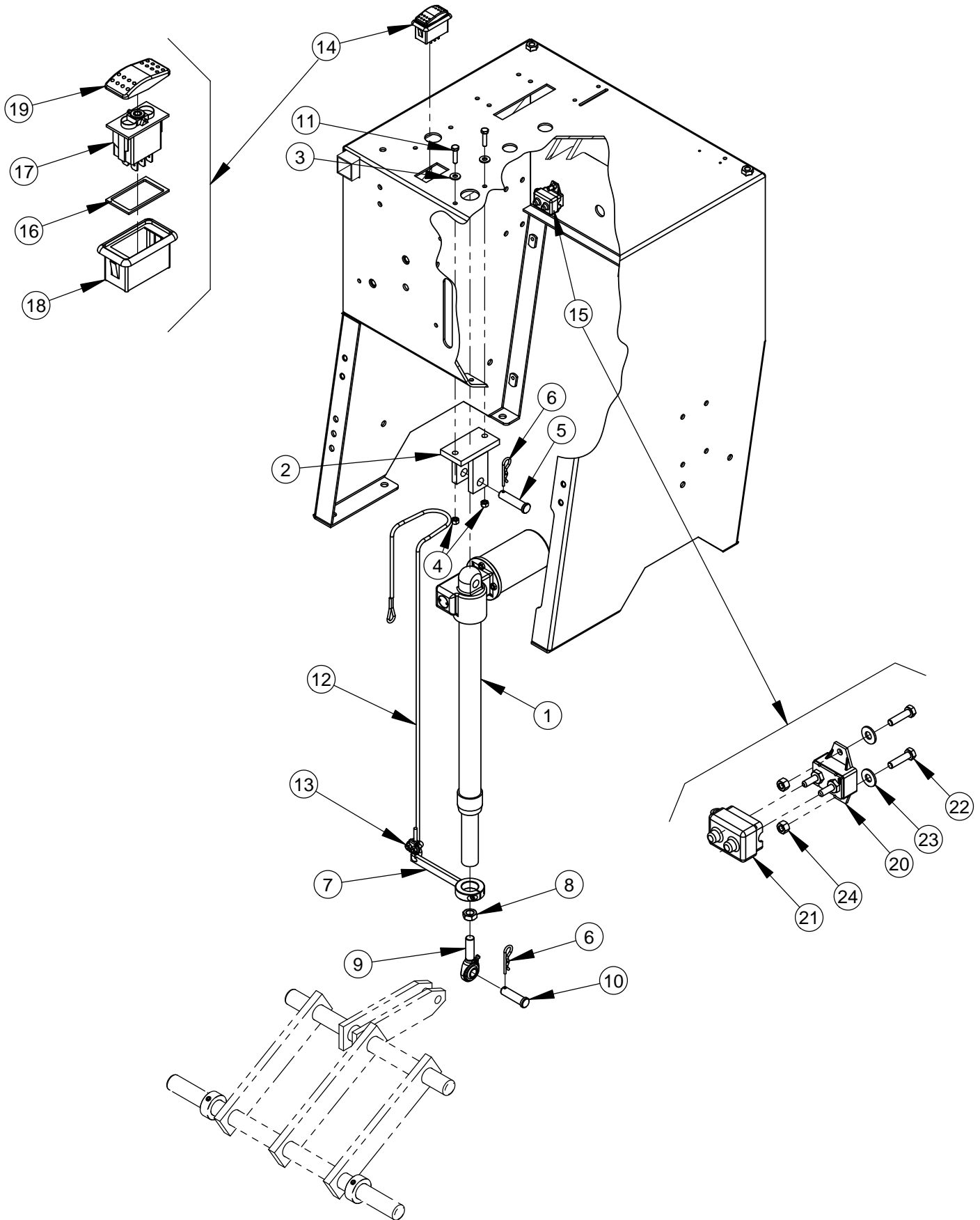

Electric Power Raise/Lower Assembly
#6047967

ITEM	PART NO.	QTY.	DESCRIPTION
1	2500930	1	Actuator
2	6047965	1	Actuator Clevis
3	2900009	2	Flat Washer, 1/4" SAE
4	2900302	2	Lock Nut, M6-1.0 Nylon Insert
5	2900393	1	Clevis Pin, 1/2 x 1-3/4", Zinc Plated
6	2900276	2	Hairpin Cotter, 1/8" x 1/2" to 3/4"
7	6047966	1	Cable Connecting Arm
8	2900109	1	Jam Nut, 1/2-20
9	2500931	1	Rod End, 1/2-20 Male
10	2900354	1	Clevis Pin, 1/2" x 1-3/4"
11	2900311	2	Cap Screw, Hex Hd., M6-1.0 x 25mm
12	6047968	1	Depth Indicator Cable
13	2500214	1	Cable Clamp
14	6019158	1	Rocker Switch Assembly
15	6047979	1	Circuit Breaker Assembly

Rocker Switch Assembly
#6019158

ITEM	PART NO.	QTY.	DESCRIPTION
16	2800261	1	Rocker Panel Gasket
17	2800258	1	Rocker Switch Body
18	2800260	1	Rocker Mount Panel
19	2800259	1	Rocker Switch Actuator

Circuit Breaker Assembly
#6047979

ITEM	PART NO.	QTY.	DESCRIPTION
20	2800363	1	Circuit Breaker 20 Amp
21	2800364	1	Circuit Breaker Boot
22	2900309	2	Cap Screw, Hex Hd., M5-0.8 x 20mm
23	2900016	2	Flat Washer, #10 USS
24	2900301	2	Lock Nut, M5-0.8 Nylon Insert

Alternator Assembly Option for 230/460V Electric Saws
#6047896

MUST DRILL ADDITIONAL HOLE
IN STARTER BOX BASE, OR
SWAP BASE WITH 6048508.

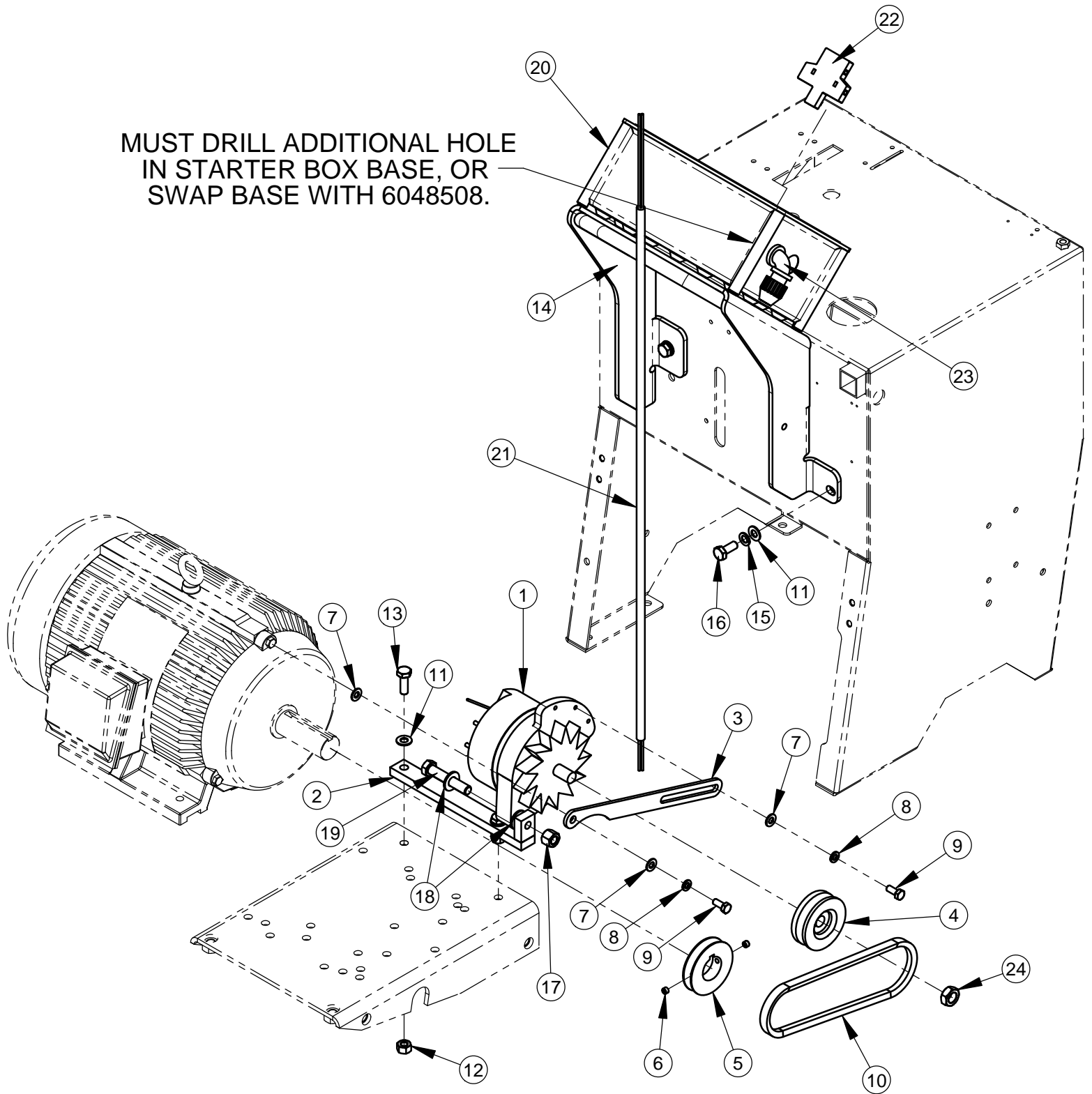

Alternator Assembly Option for 230/460V Electric Saws #6047896

ITEM	PART NO.	QTY.	DESCRIPTION
1	2500980	1	Alternator, 12V, 37A
2	6047971	1	Alternator Mount Bar
3	6047972	1	Adjustment Arm
4	2500981	1	Alternator Pulley 3"
5	6047973	1	Alternator Drive Pulley
6	2900036	2	Set Screw, Soc. Hd., 5/16-18 x 1/4"
7	2900022	3	Flat Washer, 5/16" SAE
8	2900031	2	Lock Washer, 5/16" Split
9	2900019	2	Cap Screw, Hex Hd., 5/16-18 x 3/4"
10	2500982	1	V-Belt, 4L-260
11	2900014	6	Flat Washer, 3/8" SAE
12	2900304	2	Lock Nut, M10-1.5 Nylon Insert
13	2900223	2	Cap Screw, Hex Hd., M10-1.5 x 30mm
14	6047987	1	Frame Lift Weldment
15	2900321	4	Lock Washer, M10 Split
16	2900333	4	Cap Screw, Hex Hd., M10-1.5 x 25mm
17	2900026	1	Lock Nut, 1/2-13 Nylon
18	2900058	2	Flat Washer, 1/2" SAE
19	2900105	1	Cap Screw, Hex Hd., 1/2-13 x 2-3/4"
20	6048508	1	Starter Box Base W/M6 inserts
21	6040298	1	Cord, SO 12/3 X 42"
22	2801676	1	Auxiliary Contacts, 1NO-NC
23	2801630	1	Cord Connector, 1/2", .40-.56" Cord, 90 Deg.
24	2900685	1	Jam Nut, 5/8-18

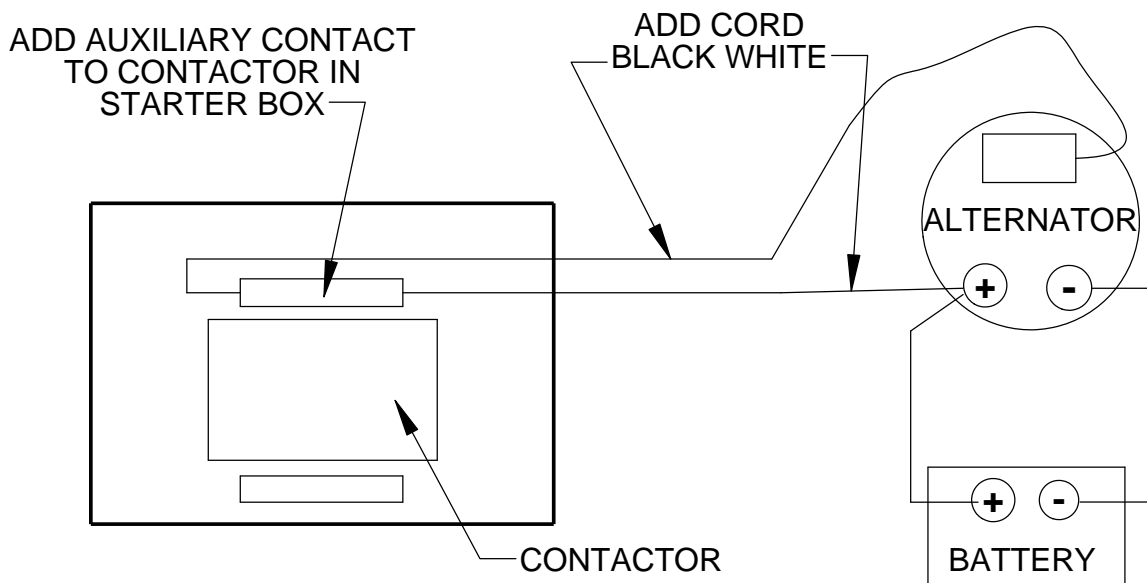

Alternator Assembly Option for Electric 575V Saws
#6048407

MUST DRILL ADDITIONAL HOLE
IN STARTER BOX BASE, OR
SWAP BASE WITH 6048508.

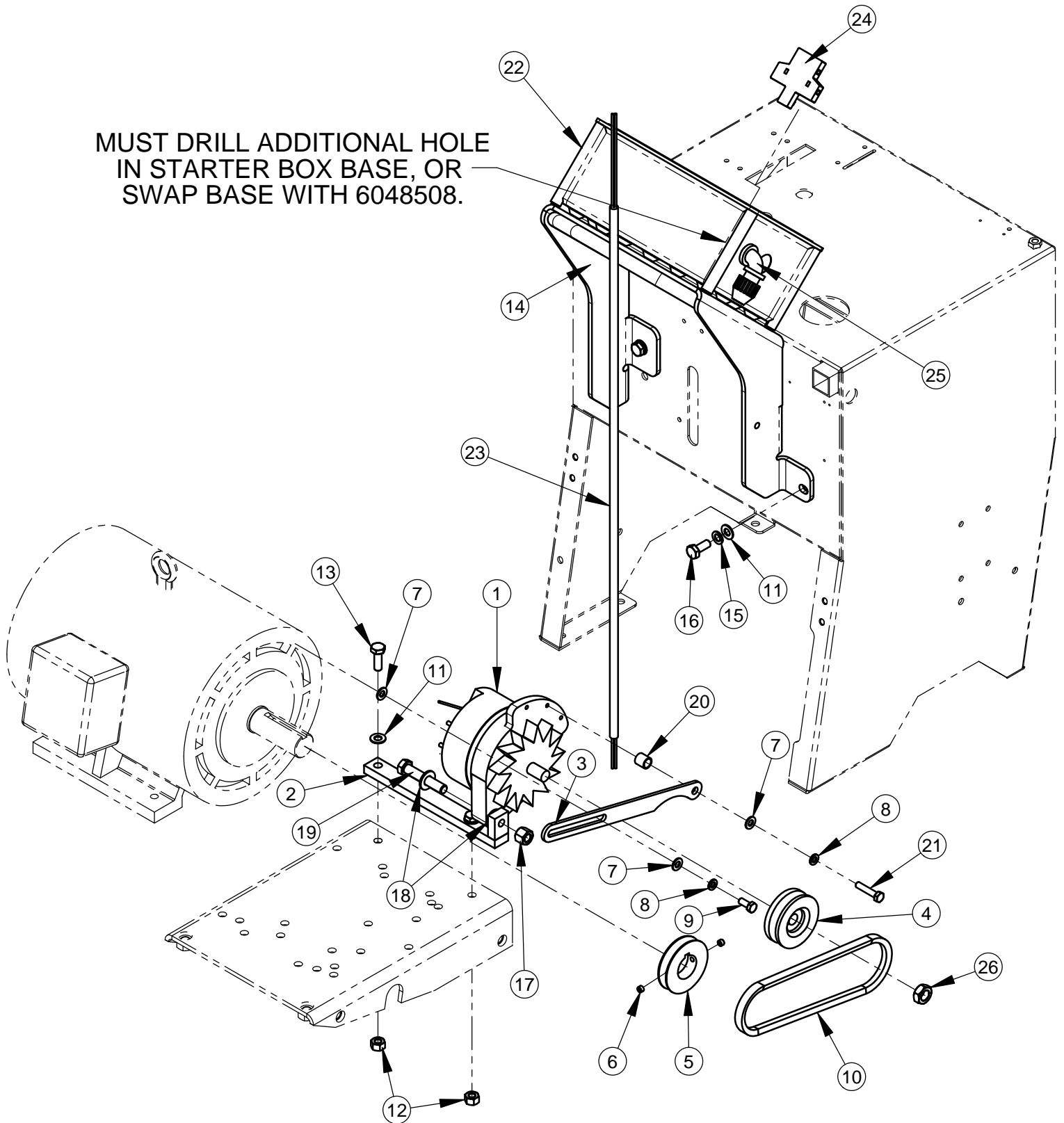

Alternator Assembly Option for Electric 575V Saws #6048407

ITEM	PART NO.	QTY.	DESCRIPTION
1	2500980	1	Alternator, 12V, 37A
2	6047971	1	Alternator Mount Bar
3	6047972	1	Adjustment Arm
4	2500981	1	Alternator Pulley 3"
5	6047973	1	Alternator Drive Pulley
6	2900036	2	Set Screw, Soc. Hd., 5/16-18 x 1/4"
7	2900022	3	Flat Washer, 5/16" SAE
8	2900031	2	Lock Washer, 5/16" Split
9	2900019	1	Cap Screw, Hex Hd., 5/16-18 x 3/4"
10	2500982	1	V-Belt, 4L-260
11	2900014	6	Flat Washer, 3/8" SAE
12	2900304	2	Lock Nut, M10-1.5 Nylon Insert
13	2900223	2	Cap Screw, Hex Hd., M10-1.5 x 30mm
14	6047987	1	Frame Lift Weldment
15	2900321	4	Lock Washer, M10 Split
16	2900333	4	Cap Screw, Hex Hd., M10-1.5 x 25mm
17	2900026	1	Lock Nut, 1/2-13 Nylon
18	2900058	2	Flat Washer, 1/2" SAE
19	2900105	1	Cap Screw, Hex Hd., 1/2-13 x 2-3/4"
20	6040563	1	Bushing, Steel 1/2 ID x 5/8 OD x 5/8 Long
21	2900508	1	Cap Screw, Hex Hd., 5/16-18 x 1-1/2"
22	6048508	1	Starter Box Base W/M6 inserts
23	6040298	1	Cord, SO 12/3 X 42"
24	2801676	1	Auxiliary Contacts, 1NO-NC
25	2801630	1	Cord Connector, 1/2", .40-.56" Cord, 90 Deg.
26	2900685	1	Jam Nut, 5/8-18

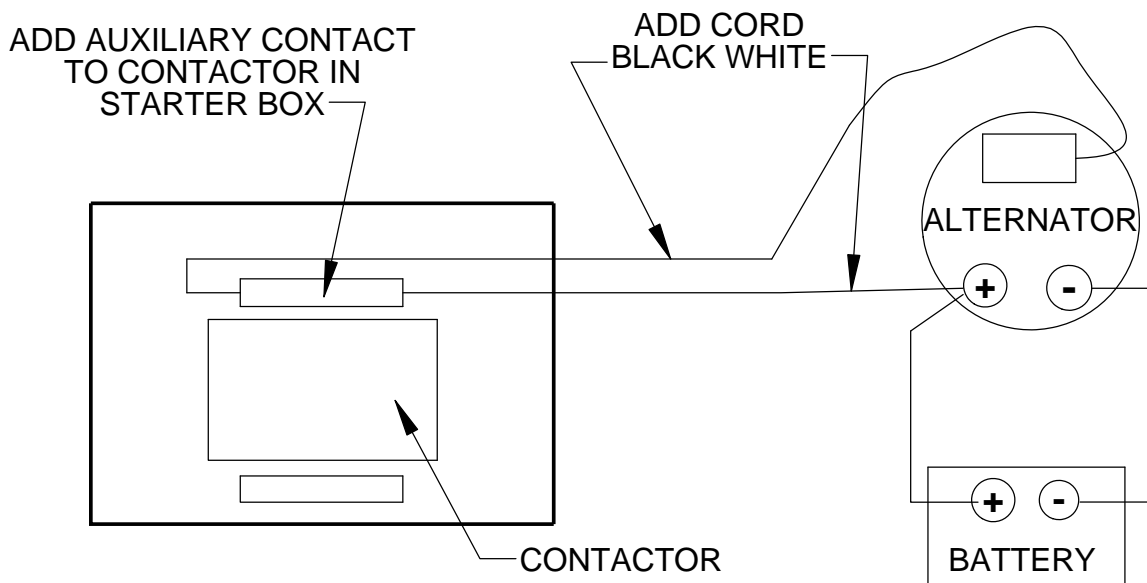

Hydraulic Power Raise/Lower Assembly #6047997

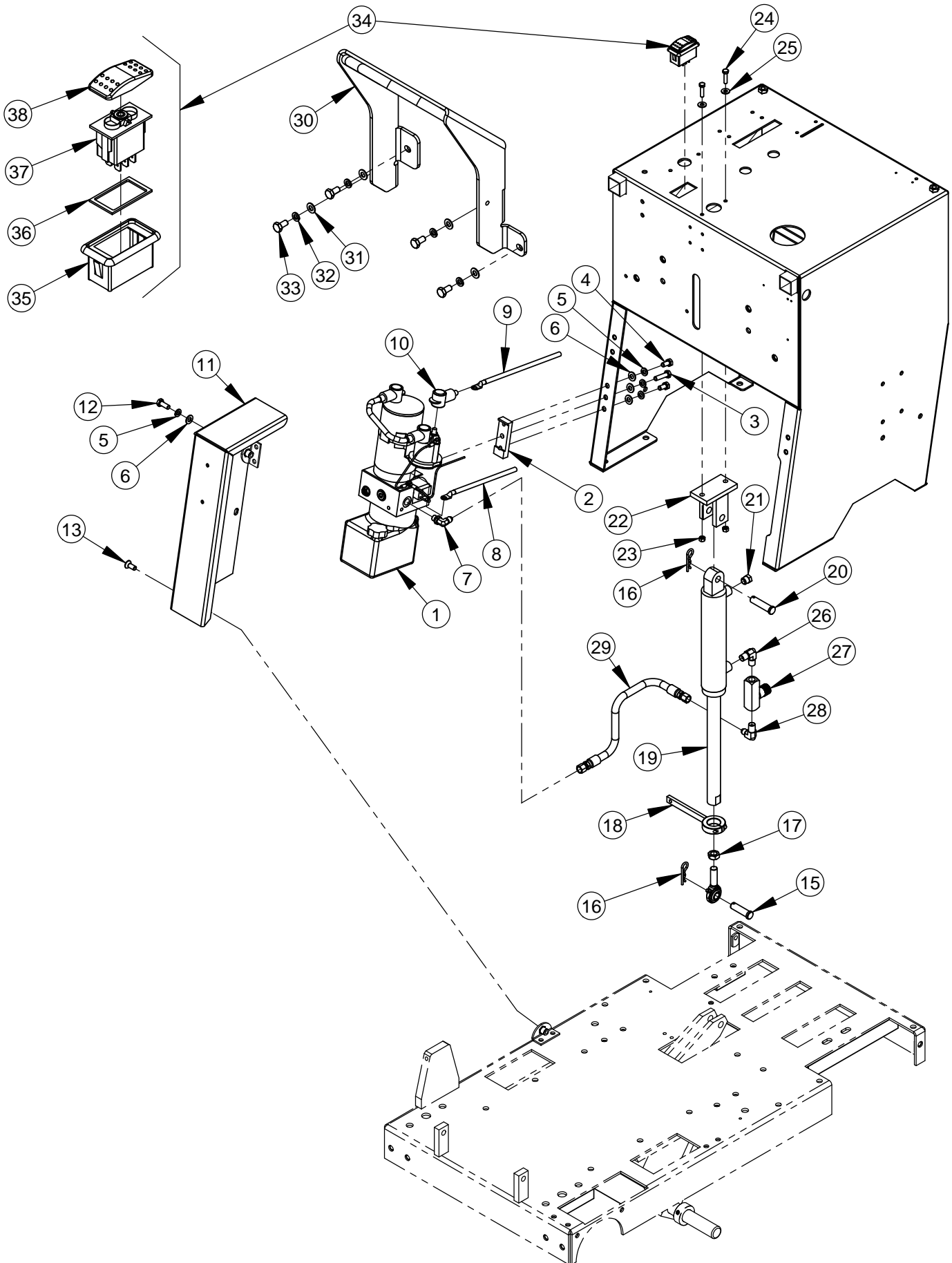

Hydraulic Power Raise/Lower Assembly
#6047997

ITEM	PART NO.	QTY.	DESCRIPTION
1	2600692	1	Electro/Hydraulic Pump Unit
2	6011565	1	Bracket, Lift Pump
3	2900217	1	Cap Screw, Hex Hd., 5/16-18 x 1-1/4"
4	2900883	2	Cap Screw, Hex Hd., 5/16-18 x 5/8"
5	2900031	4	Lock Washer, 5/16" Split
6	2900022	4	Flat Washer, 5/16" SAE
7	3200214	1	Elbow, 1/4" M. O-Ring to 1/4" M. JIC
8	6048092	1	Battery Cable Assy., Black
9	6047990	1	Battery Cable Assy., Red
10	2800197	1	Battery Boot, Small (Red)
11	6047986	1	Pump Guard
12	2900329	1	Cap Screw, Hex Hd., M8-1.25 x 20mm
13	2900611	1	Cap Screw, Flat Hd., M8-1.25 x 20mm
14	2500931	1	Rod End, 1/2-20 Male
15	2900354	1	Clevis Pin, 1/2" x 1-3/4"
16	2900276	2	Hairpin Cotter, 1/8" x 1/2" to 3/4"
17	2900109	1	Jam Nut, 1/2-20
18	6047966	1	Cable Connecting Arm
19	2501588	1	Hydraulic Cylinder
20	2900393	1	Clevis Pin, 1/2 x 1-3/4", Zinc Plated
21	3200067	1	Breather Vent, 1/4" NPT
22	6047965	1	Actuator Clevis
23	2900302	2	Lock Nut, M6-1.0 Nylon Insert
24	2900311	2	Cap Screw, Hex Hd., M6-1.0 x 25mm
25	2900009	2	Flat Washer, 1/4" SAE
26	3200312	1	Elbow, 1/4" Male Pipe
27	3200056	1	Flow Control Valve, 1/4" NPT
28	3200057	1	Elbow, 1/4" M. Pipe to 1/4" M. JIC
29	6010248	1	Hose Assembly, 20" Long
30	6047987	1	Frame Lift Weldment
31	2900014	4	Flat Washer, 3/8" SAE
32	2900006	4	Lock Washer, 3/8" Split
33	2900314	4	Cap Screw, Hex Hd., M10-1.5 x 20mm
34	6019158	1	Rocker Switch Assembly

Rocker Switch Assembly
#6019158

ITEM	PART NO.	QTY.	DESCRIPTION
35	2800260	1	Rocker Mount Panel
36	2800261	1	Rocker Panel Gasket
37	2800258	1	Rocker Switch Body
38	2800259	1	Rocker Switch Actuator

Alternator Assembly Option for Hydraulic Saws (Power Raise)
#6047895

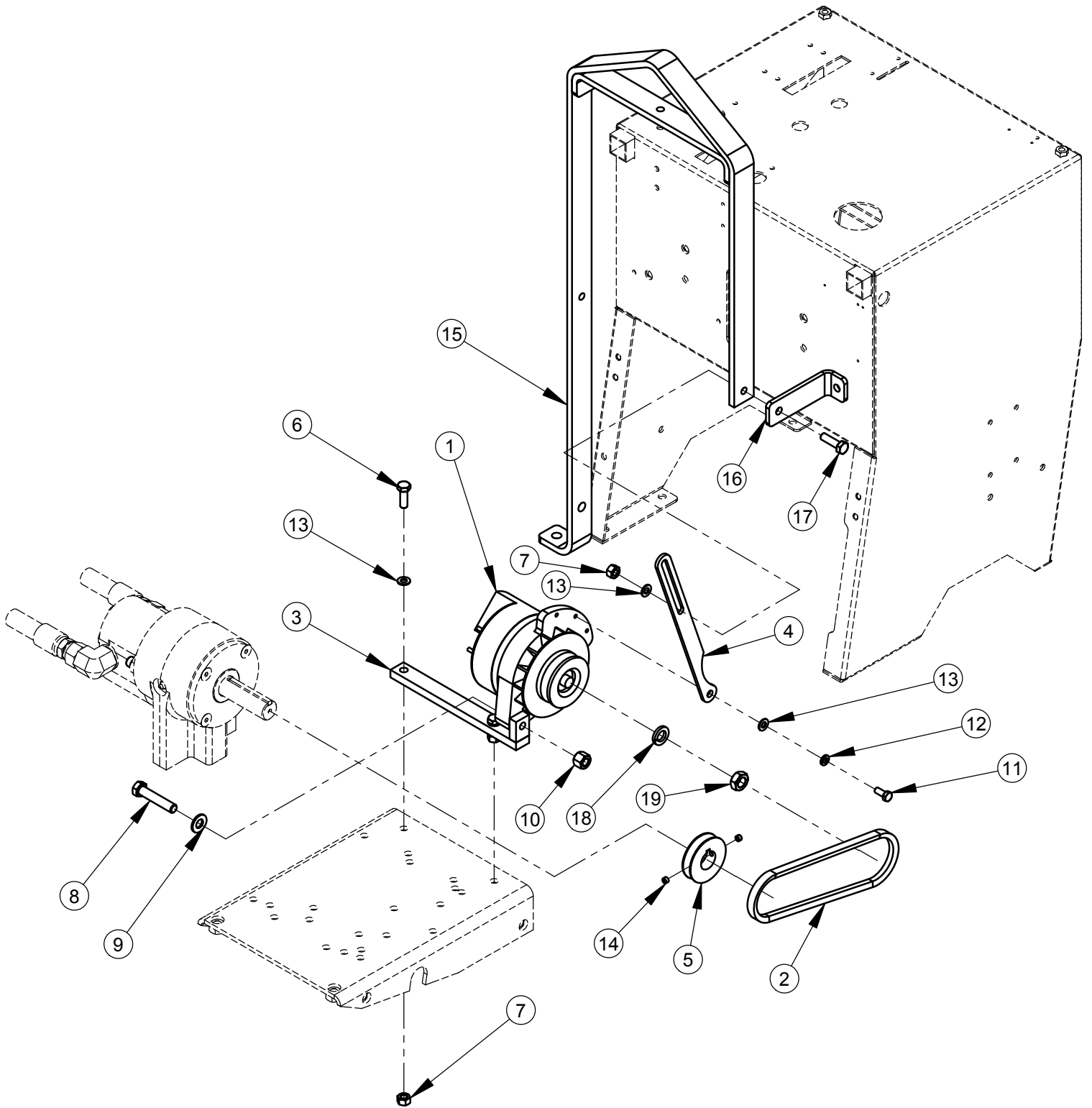

Alternator Assembly Option for Hydraulic Saws (Power Raise)
#6047895

ITEM	PART NO.	QTY.	DESCRIPTION
1	2501256	1	Alternator
2	2500982	1	V-Belt, 4L-260
3	6047971	1	Alternator Mount Bar
4	6047972	1	Adjustment Arm
5	6048195	1	Accessory Drive Pulley
6	2900223	2	Cap Screw, Hex Hd., M10-1.5 x 30mm
7	2900304	3	Lock Nut, M10-1.5 Nylon Insert
8	2900811	1	Cap Screw, Hex Hd., 1/2-13 x 2-1/2"
9	2900058	1	Flat Washer, 1/2" SAE
10	2900026	1	Lock Nut, 1/2-13 Nylon
11	2900019	1	Cap Screw, Hex Hd., 5/16-18 x 3/4"
12	2900031	1	Lock Washer, 5/16" Split
13	2900022	4	Flat Washer, 5/16" SAE
14	2900036	2	Set Screw, Soc. Hd., 5/16-18 x 1/4"
15	6047984	1	Frame Lift
16	6047953	1	Frame Lift Brace
17	2900315	1	Cap Screw, Hex Hd., M10-1.5 x 35mm
18	2900113	1	Lock Washer, 5/8" Split
19	2900685	1	Jam Nut, 5/8-18

Battery Assembly #6047958

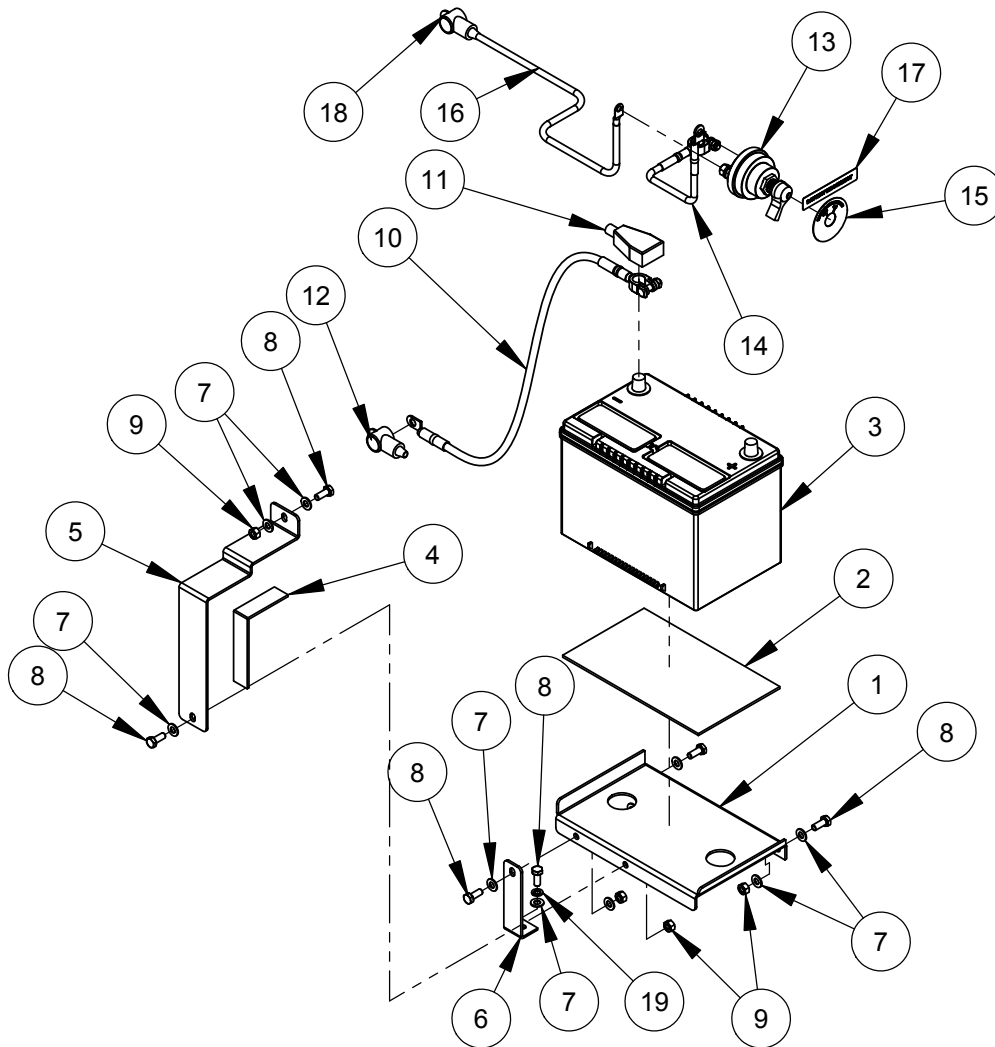

ITEM	PART NO.	QTY.	DESCRIPTION
1	6047920	1	Battery Holder
2	6010016	1	Battery Pad
3	2700208	1	Battery, 12 Volt Group Size 34
4	6048077	1	Rubber Strip
5	6047922	1	Battery Strap
6	6047921	1	Battery Support Brace
7	2900022	10	Flat Washer, 5/16" SAE
8	2900329	6	Cap Screw, Hex Hd., M8-1.25 x 20mm
9	2900303	5	Lock Nut, M8-1.25 Nylon Insert
10	2800072	1	Battery Cable, 30" Negative (Black)
11	2800257	1	Battery Boot, Large (Black)
12	2800198	1	Battery Boot, Small (Black)
13	2800565	1	Battery Disconnect Switch
14	2800572	1	Battery Cable, 9" Positive (Red)
15	2800566	1	Face Plate, Battery Disconnect
16	6048091	1	Battery Cable Assy., Red
17	1800846	1	Label, Battery Disconnect
18	2800197	1	Battery Boot, Small (Red)
19	2900763	1	Lock Washer, M8 Split

Water Pump Option #6047933

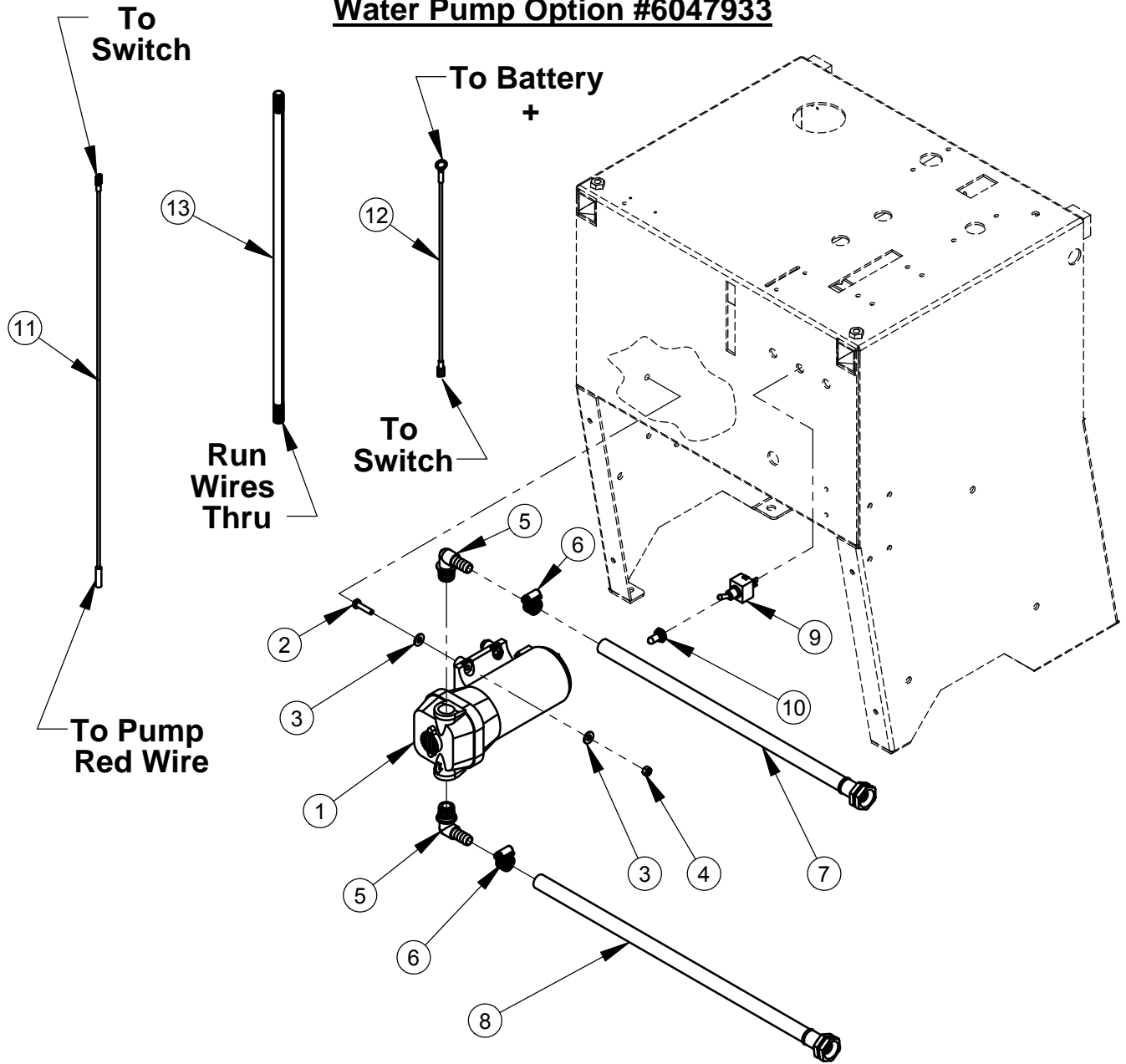

ITEM	PART NO.	QTY.	DESCRIPTION
1	2600200	1	Water Pump, 12V Diaphragm
2	2900311	4	Cap Screw, Hex Hd., M6-1.0 x 25mm
3	2900009	8	Flat Washer, 1/4" SAE
4	2900302	4	Lock Nut, M6-1.0 Nylon Insert
5	2701694	2	Port Fitting, 1/2" Barb x 90 Degree
6	3200016	2	Hose Clamp #8
7	6048167	1	Hose Assy., 3 Foot
8	6010302	1	Hose Assy., 4 Foot
9	2800062	1	Toggle Switch On/Off
10	2800063	1	Toggle Switch Boot
11	6040371	1	Wire Assy., 14 GA., Green 24"
12	6040372	1	Wire Assy., 14 GA., White 12"
13	4600087	1	Wire Cover, 3/8 x 20"

6047934 CC2500 SPOT LIGHT KIT

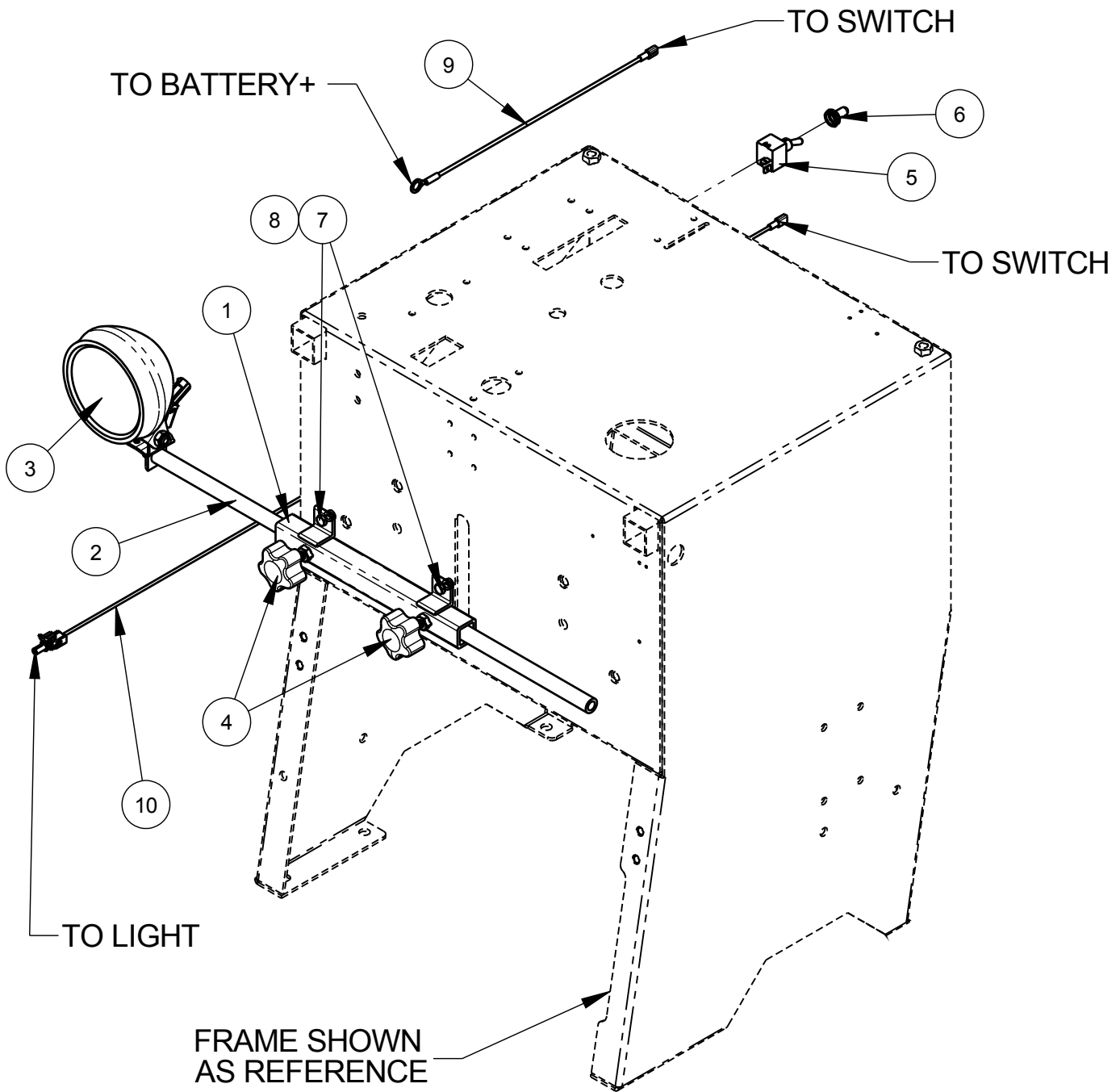

ITEM	PART NO.	QTY.	DESCRIPTION
1	6010107	1	Light Bar Mount Bracket
2	6010106	1	Light Bar
3	6011719	1	Light, 12V Spot Assy.
4	2400157	2	Hand Lock Knob, 5/16-18 x 1"
5	2800062	1	Toggle Switch On/Off
6	2800063	1	Switch Boot
7	2900310	2	Cap Screw, Hex Hd., M6 x 20mm
8	2900302	2	Lock Nut, M6 Nylon
9	6010859	1	Wire Assy., 16 Ga., White, 13"
10	6010852	1	Wire Assy., 18 Gage, Black, 41-1/4"
11	6047901	1	Frame Upright Weldment

WATER SAFETY SWITCH OPTION
**(FOR ALL ENGINES/MOTORS EXCEPT HONDA V-TWIN
MODELS #GX630/GX660/GX690)**

EMERGENCY STOP BUTTON

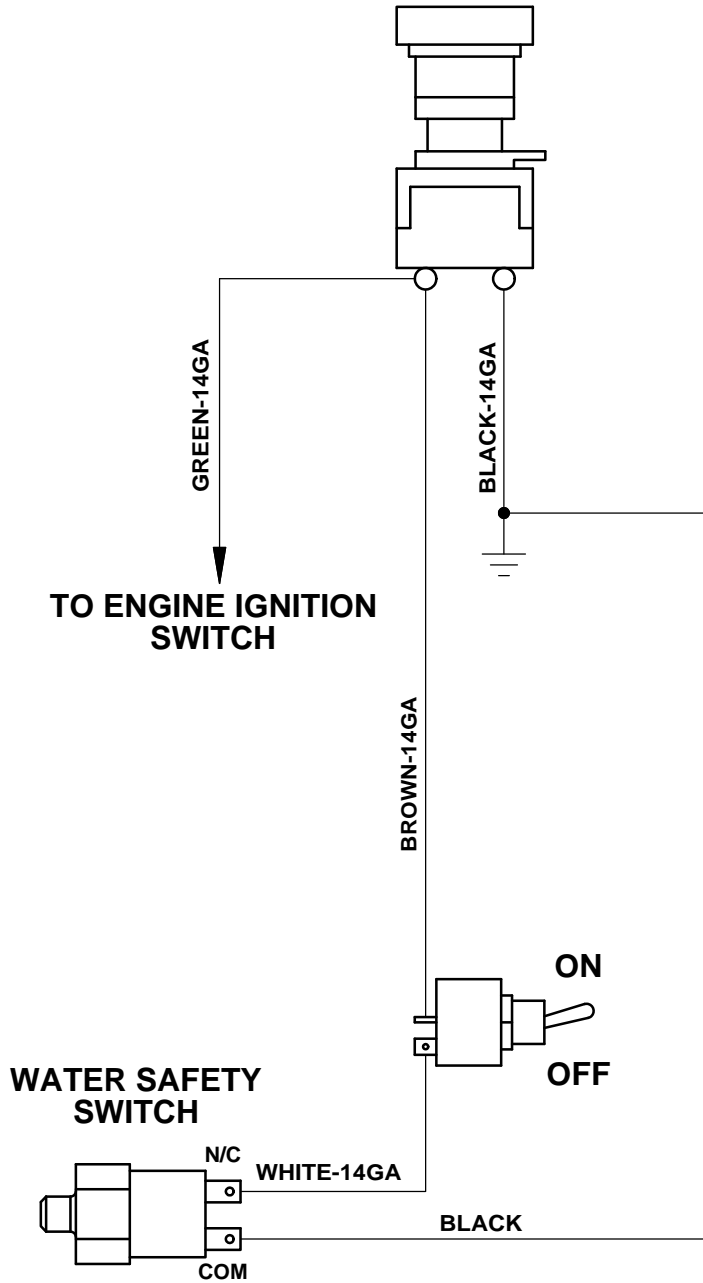

Optional Electric Raise/Lower Wiring Diagram

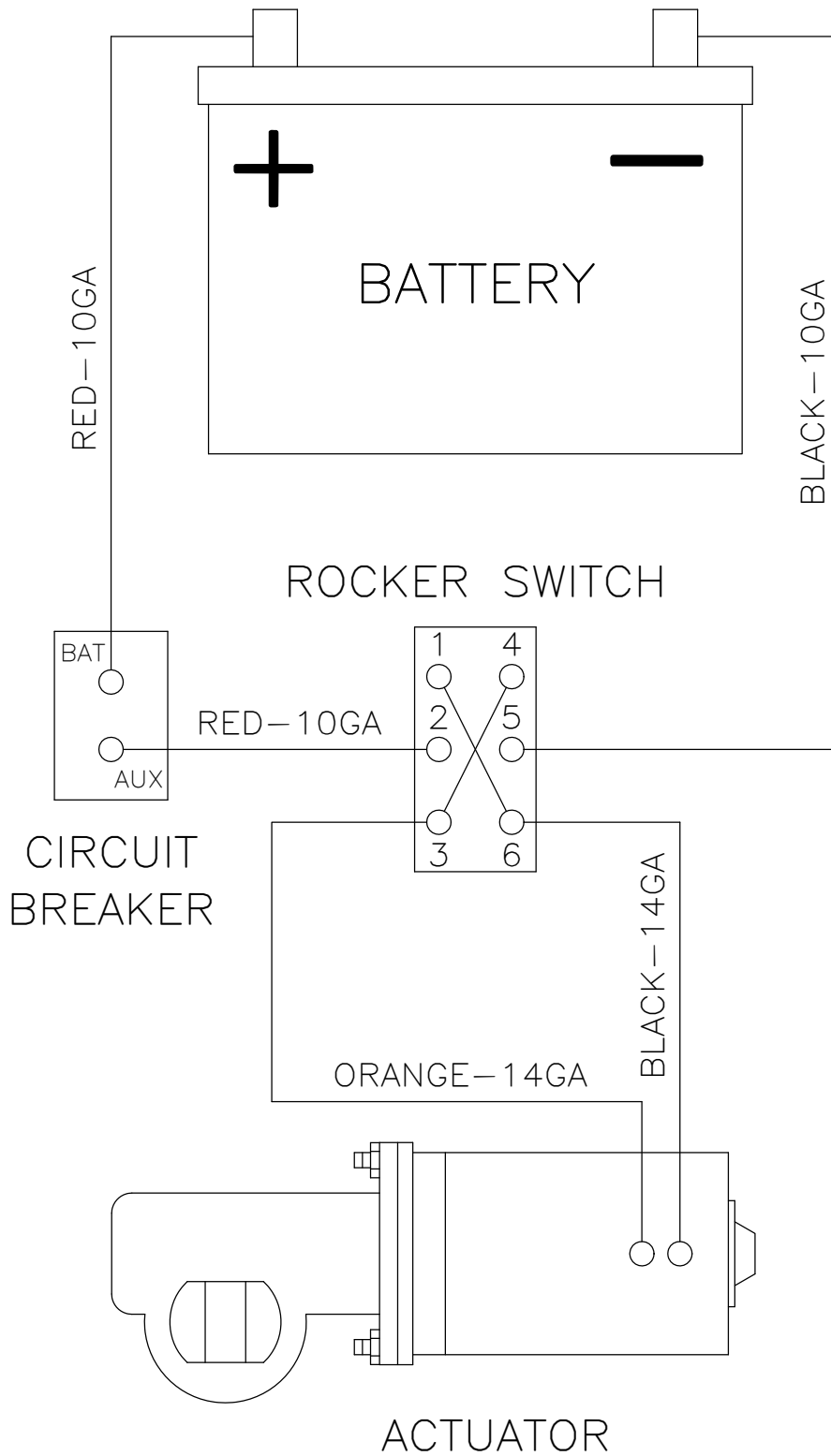

Optional Hydraulic Raise/Lower Wiring Diagram

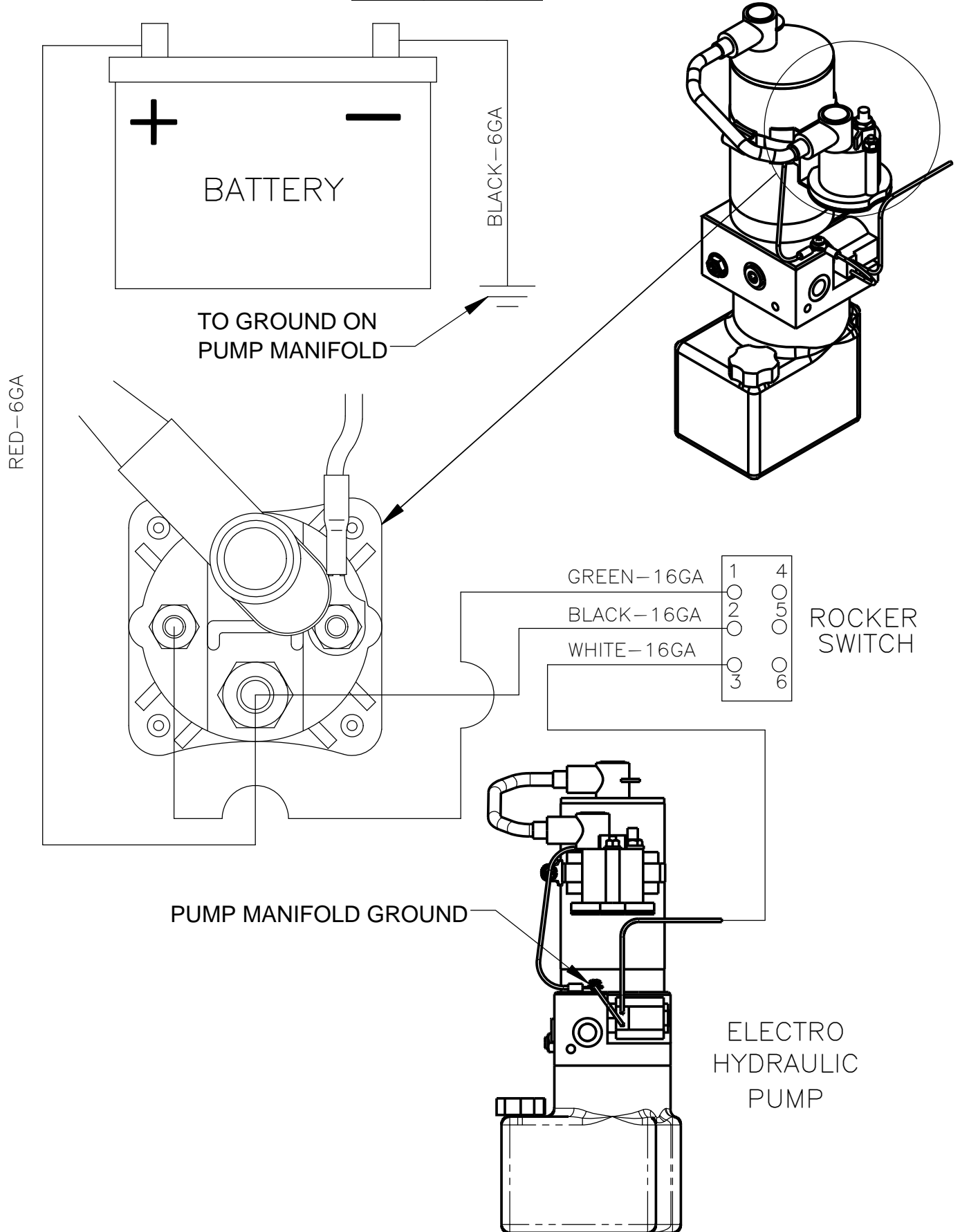

Optional Water Pump Wiring Diagram

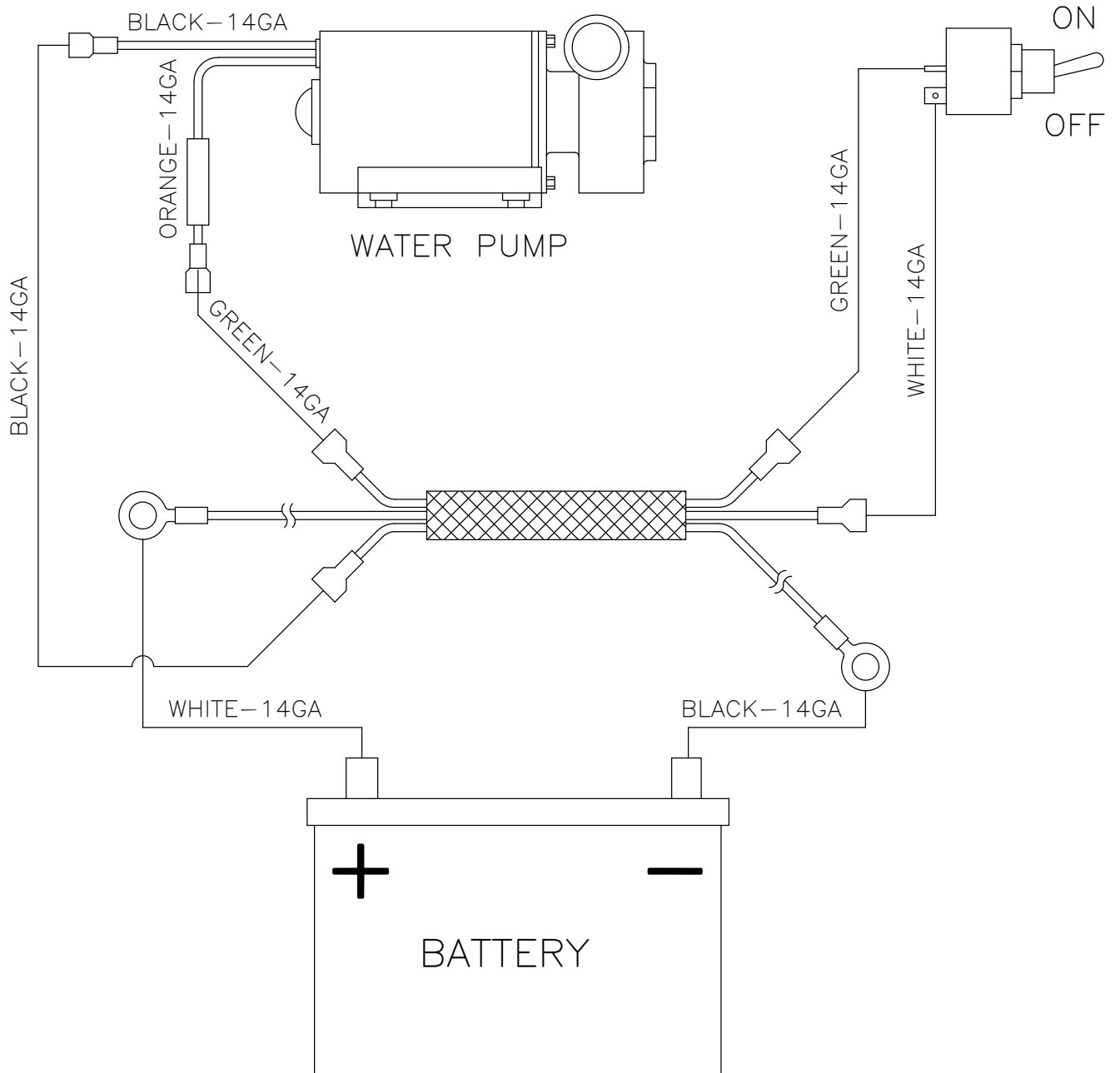

**Optional Spotlight
Wiring Diagram**

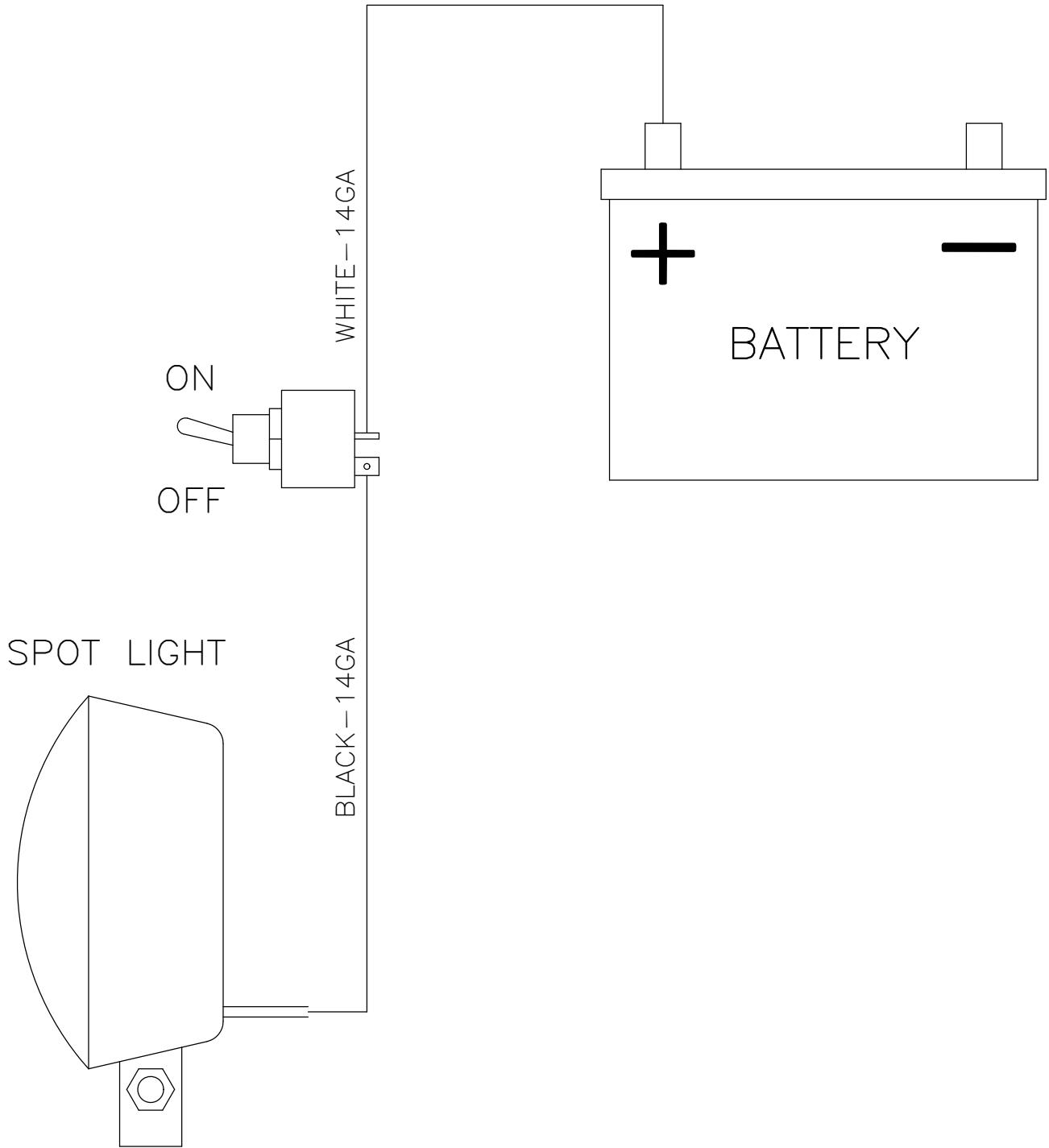

Decal Group



SAW LABEL SHEET
#1800417



CORE CUT DECAL
#1800416 (QTY. 2)



WARNING DECAL
#1800001

EQUIPMENT AND PARTS WARRANTY

Diamond Products warrants all equipment manufactured by it against defects in workmanship or materials for a period of one (1) year from the date of shipment to Customer.

The responsibility of Diamond Products under this Warranty is limited to replacement or repair of defective parts at Diamond Products' Elyria, Ohio factory, or at a point designated by it, of such parts as shall appear to us upon inspection at such parts, to have been defective in material or workmanship, with expense for transportation and labor borne by Customer.

In no event shall Diamond Products be liable for consequential or incidental damages arising out of the failure of any Product to operate properly.

Integral units such as engines, electric motors, batteries, transmissions, etc., are excluded from this Warranty and are subject to the prime manufacturer's warranty.

THIS WARRANTY IS IN LIEU OF ALL OTHER WARRANTIES, EXPRESSED OR IMPLIED, AND ALL SUCH OTHER WARRANTIES ARE HEREBY DISCLAIMED.

