



**CORE POWER
PARTS LIST/OPERATOR'S
MANUAL**

**CP15EXL
HYDRAULIC POWER UNIT**

MARCH 2023

Part #: 1801653-8

CP POWER PACK FLOW AND PRESSURE RATING

CP POWER PACK MODEL	MAXIMUM <u>NO</u> <u>LOAD</u> FLOW GPM/LPM	RELIEF SETTING PSI/BAR
15 Electric	12.75 / 48.2	2100 / 145
18 Briggs Vanguard	11.6 / 43.9	2850 / 196.5
20 Electric	14.9 / 56.4	2400 / 165.5
21 Honda	14.1 / 53.2	2600 / 179.3
30 Electric	20.4 / 77.2	2300 / 158.6
35 Briggs Vanguard	17.2 / 65.1	3000 / 206.9

Maximum no load flow is based on pump and motor manufacturer's specifications for pump displacement and no load RPM. Relief is set to insure gas engines cannot reach their stall torque and electric motors will not exceed the recommended current limit.

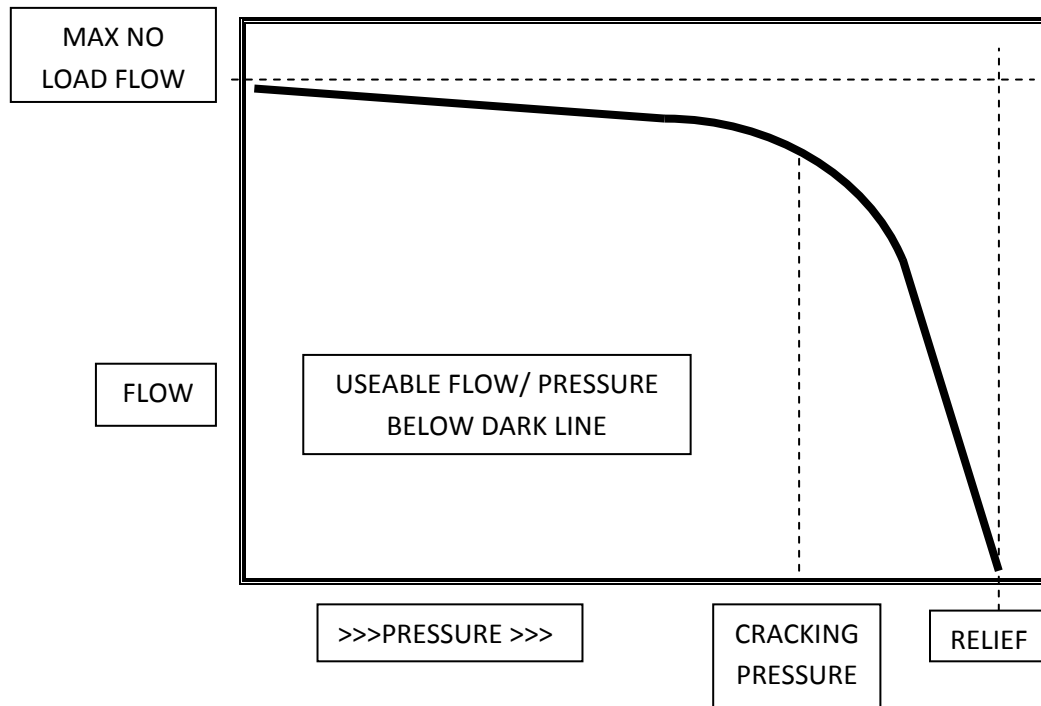

Flow decreases as engine/motor RPM drops under load. Relief valves begin to open and shunt flow to tank at 75-80% of the relief setting (cracking pressure). This further reduces flow to the tool. At relief, all flow is directed to tank.

Issued August 2011

Table of Contents

<u>Description</u>	<u>Page No.</u>
1. 208/230/460 Volt Hydraulic Power Supply	4
2. 575 Volt Hydraulic Power Supply	8
3. Hydraulic Schematic	12
4. Hose Kit	13
5. Hydraulic Tank Assembly	14
6. Control Panel Assembly	16
8. Starter Box Assembly 208-460 Volt	18-21
9. Starter Box Assembly 550-600 Volt	22-25
10. Tool Tray Option.....	26
11. Wheel Upgrade Kit.....	27
12. Component Locations.....	28
13. Safety Precautions	29
14. Descriptions and Specifications	31
15. Operating Instructions	32
16. Operating Driven Equipment	33
17. Maintenance Instructions	33
18. Troubleshooting	34

4646206 CP15 HYDRAULIC POWER SUPPLY, 208 - 460 VOLT

ITEM	PART NO.	QTY.	DESCRIPTION
1	4646156	1	CP-XL Frame Assembly
2	2400643	2	Wheel, 12 x 2-3/8 x 3/4"
3	2400615	2	Set Collar, 3/4"
4	2501767	2	Rubber Bumper
5	2901103	2	Fender Washer, 5/16" x 1"
6	2900022	14	Flat Washer, 5/16" SAE
7	2900508	2	Cap Screw, Hex Hd., 5/16-18 x 1-1/2"
8	2900039	8	Lock Nut, 5/16-18 Nylon
9	4600079	1	Electric Motor, 15 HP, 3 Ph., 230/460 V.
10	2800083	9	Terminal, #10 Ring (16-14 AWG) Blue
11	2900016	18	Flat Washer, #10 USS
12	2900159	9	Machine Screw, Rd. Hd., #10-24 x 5/8"
13	2900017	9	Lock Nut, #10-24 Nylon
14	2800193	1	Lock Nut, 1"
15	2800312	1	Connector, 1" Sealtite Elbow
16	2900014	8	Flat Washer, 3/8" SAE
17	2900013	4	Cap Screw, Hex Hd., 3/8-16 x 1-1/4"
18	2900018	4	Locknut, 3/8-16, Nylon
19	2701801	1	Coupling Assembly, 1-3/8 - 3/4" Shafts
20	2400309	1	Pump Mount
21	2900084	4	Lock Washer, 1/2" Split
22	2900511	4	Cap Screw, Soc. Hd., 1/2-13 x 1-1/4"
23	2600490	1	Hydraulic Pump, .85 CI
24	2900006	2	Lock Washer, 3/8" Split
25	2900005	2	Cap Screw, Hex Hd., 3/8-16 x 1"
26	3200298	1	Elbow, 3/4" O-Ring to 1/2" M. JIC
27	3200297	1	Elbow, 1" O-Ring to 1" M. JIC
28	4646173	1	Hydraulic Tank Assembly
29	4646174	1	Panel Assembly, CP15
30	4646035	1	Fuel Tank Support
31	2900009	2	Flat Washer, 1/4" SAE
32	2900024	6	Lock Washer, 1/4" Split
33	2900008	2	Cap Screw, Hex Hd., 1/4-20 x 1"
34	4641098	1	Starter Box Platform
35	2900138	4	Cap Screw, Hex Hd., 5/16-18 x 1"
36	4646049	1	Side Panel
37	2900144	4	Cap Screw, Hex Hd., 1/4-20 x 3/4"
38	4646006	2	Handle
39	2500636	2	Handle Grip
40	2900257	2	Lock Pin, T Handle, 3/8"
41	2900053	4	Rivet, 3/32" Dia.
42	4646003	1	Lifting Bar
43	2900248	2	Cap Screw, Hex Hd., 5/16-18 x 3"
44	1800169	1	Serial Number Plate, US
45	4646143	1	Hose Kit
46	1802755	1	Decal, Core Power CP15

4646206 CP15 HYDRAULIC POWER SUPPLY 208 - 460 VOLT

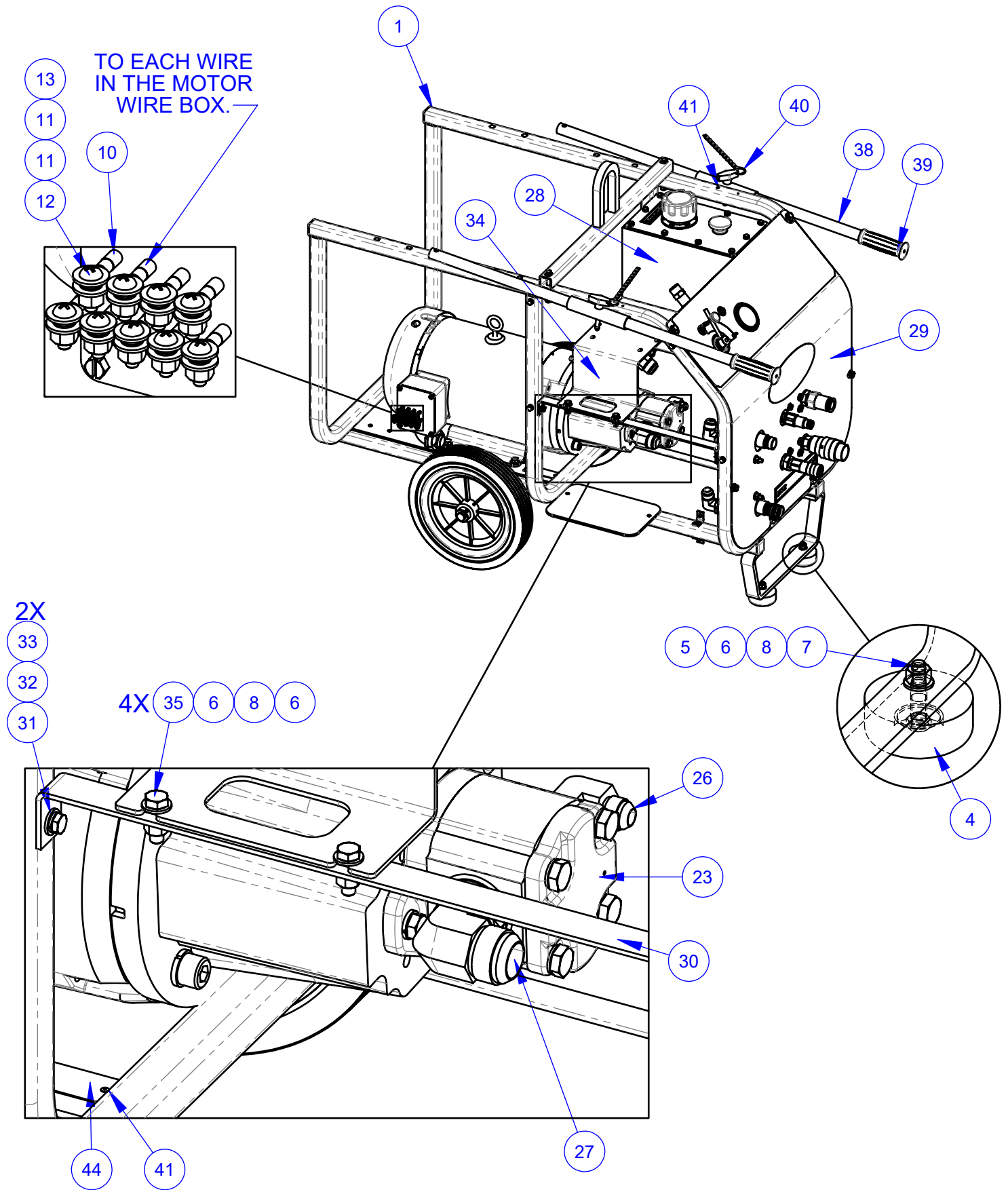

4646206 CP15 HYDRAULIC POWER SUPPLY, 208 - 460 VOLT

ITEM	PART NO.	QTY.	DESCRIPTION
1	4646156	1	CP-XL Frame Assembly
2	2400643	2	Wheel, 12 x 2-3/8 x 3/4"
3	2400615	2	Set Collar, 3/4"
4	2501767	2	Rubber Bumper
5	2901103	2	Fender Washer, 5/16" x 1"
6	2900022	14	Flat Washer, 5/16" SAE
7	2900508	2	Cap Screw, Hex Hd., 5/16-18 x 1-1/2"
8	2900039	8	Lock Nut, 5/16-18 Nylon
9	4600079	1	Electric Motor, 15 HP, 3 Ph., 230/460 V.
10	2800083	9	Terminal, #10 Ring (16-14 AWG) Blue
11	2900016	18	Flat Washer, #10 USS
12	2900159	9	Machine Screw, Rd. Hd., #10-24 x 5/8"
13	2900017	9	Lock Nut, #10-24 Nylon
14	2800193	1	Lock Nut, 1"
15	2800312	1	Connector, 1" Sealtite Elbow
16	2900014	8	Flat Washer, 3/8" SAE
17	2900013	4	Cap Screw, Hex Hd., 3/8-16 x 1-1/4"
18	2900018	4	Locknut, 3/8-16, Nylon
19	2701801	1	Coupling Assembly, 1-3/8 - 3/4" Shafts
20	2400309	1	Pump Mount
21	2900084	4	Lock Washer, 1/2" Split
22	2900511	4	Cap Screw, Soc. Hd., 1/2-13 x 1-1/4"
23	2600490	1	Hydraulic Pump, .85 CI
24	2900006	2	Lock Washer, 3/8" Split
25	2900005	2	Cap Screw, Hex Hd., 3/8-16 x 1"
26	3200298	1	Elbow, 3/4" O-Ring to 1/2" M. JIC
27	3200297	1	Elbow, 1" O-Ring to 1" M. JIC
28	4646173	1	Hydraulic Tank Assembly
29	4646174	1	Panel Assembly, CP15
30	4646035	1	Fuel Tank Support
31	2900009	2	Flat Washer, 1/4" SAE
32	2900024	6	Lock Washer, 1/4" Split
33	2900008	2	Cap Screw, Hex Hd., 1/4-20 x 1"
34	4641098	1	Starter Box Platform
35	2900138	4	Cap Screw, Hex Hd., 5/16-18 x 1"
36	4646049	1	Side Panel
37	2900144	4	Cap Screw, Hex Hd., 1/4-20 x 3/4"
38	4646006	2	Handle
39	2500636	2	Handle Grip
40	2900257	2	Lock Pin, T Handle, 3/8"
41	2900053	4	Rivet, 3/32" Dia.
42	4646003	1	Lifting Bar
43	2900248	2	Cap Screw, Hex Hd., 5/16-18 x 3"
44	1800169	1	Serial Number Plate, US
45	4646143	1	Hose Kit
46	1802755	1	Decal, Core Power CP15

4640037 CP15 HYDRAULIC POWER SUPPLY, 575 VOLT

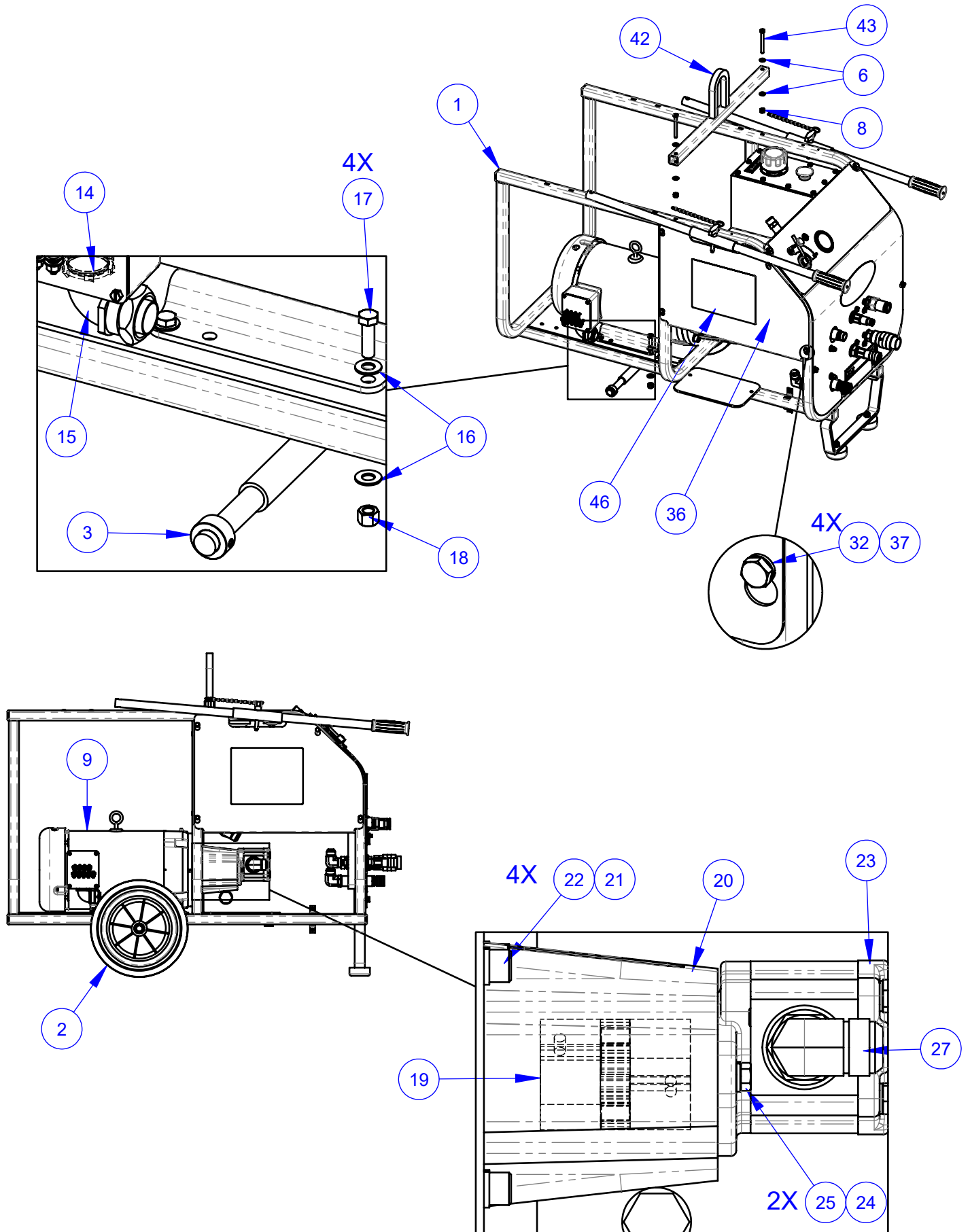

4640037 CP15 HYDRAULIC POWER SUPPLY, 575 VOLT

ITEM	PART NO.	QTY.	DESCRIPTION
1	4646156	1	CP-XL Frame Assembly
2	2400643	2	Wheel, 12 x 2-3/8 x 3/4"
3	2400615	2	Set Collar, 3/4"
4	2501767	2	Rubber Bumper
5	2901103	2	Fender Washer, 5/16" x 1"
6	2900022	14	Flat Washer, 5/16" SAE
7	2900508	2	Cap Screw, Hex Hd., 5/16-18 x 1-1/2"
8	2900039	8	Lock Nut, 5/16-18 Nylon
9	4600080	1	Electric Motor, 15HP, 3 PH., 575V.
10	2800083	9	Terminal, #10 Ring (16-14 AWG) Blue
11	2900016	18	Flat Washer, #10 USS
12	2900159	9	Machine Screw, Rd. Hd., #10-24 x 5/8"
13	2900017	9	Lock Nut, #10-24 Nylon
14	2800193	1	Lock Nut, 1"
15	2800312	1	Connector, 1" Sealtite Elbow
16	2900014	8	Flat Washer, 3/8" SAE
17	2900013	4	Cap Screw, Hex Hd., 3/8-16 x 1-1/4"
18	2900018	4	Locknut, 3/8-16, Nylon
19	2701801	1	Coupling Assembly, 1-3/8 - 3/4" Shafts
20	2400309	1	Pump Mount
21	2900084	4	Lock Washer, 1/2" Split
22	2900511	4	Cap Screw, Soc. Hd., 1/2-13 x 1-1/4"
23	2600490	1	Hydraulic Pump, .85 CI
24	2900006	2	Lock Washer, 3/8" Split
25	2900005	2	Cap Screw, Hex Hd., 3/8-16 x 1"
26	3200298	1	Elbow, 3/4" O-Ring to 1/2" M. JIC
27	3200297	1	Elbow, 1" O-Ring to 1" M. JIC
28	4646173	1	Hydraulic Tank Assembly
29	4646174	1	Panel Assembly, CP15
30	4646035	1	Fuel Tank Support
31	2900009	2	Flat Washer, 1/4" SAE
32	2900024	6	Lock Washer, 1/4" Split
33	2900008	2	Cap Screw, Hex Hd., 1/4-20 x 1"
34	4641098	1	Starter Box Platform
35	2900138	4	Cap Screw, Hex Hd., 5/16-18 x 1"
36	4646049	1	Side Panel
37	2900144	4	Cap Screw, Hex Hd., 1/4-20 x 3/4"
38	4646006	2	Handle
39	2500636	2	Handle Grip
40	2900257	2	Lock Pin, T Handle, 3/8"
41	2900053	4	Rivet, 3/32" Dia.
42	4646003	1	Lifting Bar
43	2900248	2	Cap Screw, Hex Hd., 5/16-18 x 3"
44	1800169	1	Serial Number Plate, US
45	4646143	1	Hose Kit
46	1802755	1	Decal, Core Power CP15

4640037 CP15 HYDRAULIC POWER SUPPLY, 575 VOLT

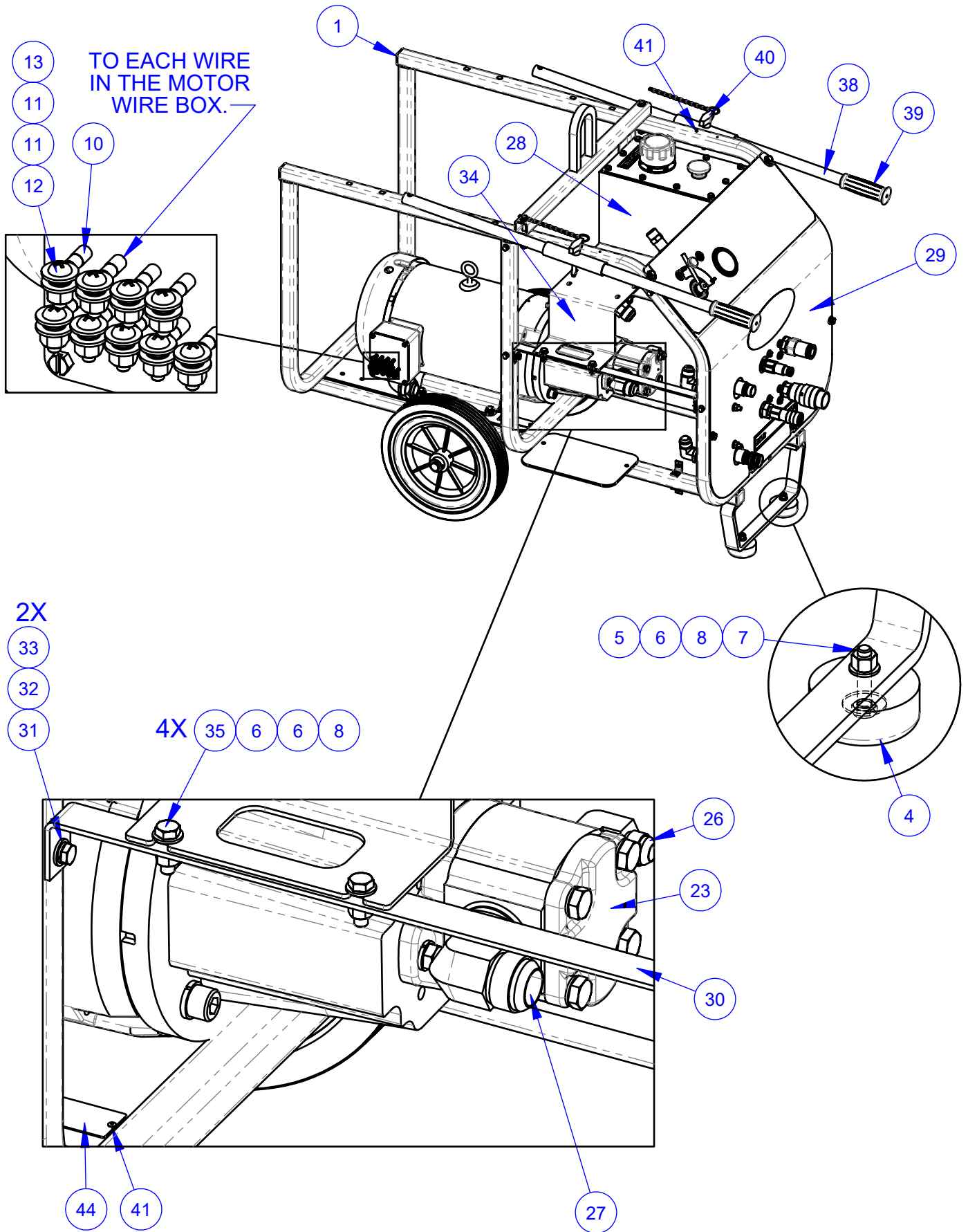

4640037 CP15 HYDRAULIC POWER SUPPLY, 575 VOLT

ITEM	PART NO.	QTY.	DESCRIPTION
1	4646156	1	CP-XL Frame Assembly
2	2400643	2	Wheel, 12 x 2-3/8 x 3/4"
3	2400615	2	Set Collar, 3/4"
4	2501767	2	Rubber Bumper
5	2901103	2	Fender Washer, 5/16" x 1"
6	2900022	14	Flat Washer, 5/16" SAE
7	2900508	2	Cap Screw, Hex Hd., 5/16-18 x 1-1/2"
8	2900039	8	Lock Nut, 5/16-18 Nylon
9	4600080	1	Electric Motor, 15HP, 3 PH., 575V.
10	2800083	9	Terminal, #10 Ring (16-14 AWG) Blue
11	2900016	18	Flat Washer, #10 USS
12	2900159	9	Machine Screw, Rd. Hd., #10-24 x 5/8"
13	2900017	9	Lock Nut, #10-24 Nylon
14	2800193	1	Lock Nut, 1"
15	2800312	1	Connector, 1" Sealtite Elbow
16	2900014	8	Flat Washer, 3/8" SAE
17	2900013	4	Cap Screw, Hex Hd., 3/8-16 x 1-1/4"
18	2900018	4	Locknut, 3/8-16, Nylon
19	2701801	1	Coupling Assembly, 1-3/8 - 3/4" Shafts
20	2400309	1	Pump Mount
21	2900084	4	Lock Washer, 1/2" Split
22	2900511	4	Cap Screw, Soc. Hd., 1/2-13 x 1-1/4"
23	2600490	1	Hydraulic Pump, .85 CI
24	2900006	2	Lock Washer, 3/8" Split
25	2900005	2	Cap Screw, Hex Hd., 3/8-16 x 1"
26	3200298	1	Elbow, 3/4" O-Ring to 1/2" M. JIC
27	3200297	1	Elbow, 1" O-Ring to 1" M. JIC
28	4646173	1	Hydraulic Tank Assembly
29	4646174	1	Panel Assembly, CP15
30	4646035	1	Fuel Tank Support
31	2900009	2	Flat Washer, 1/4" SAE
32	2900024	6	Lock Washer, 1/4" Split
33	2900008	2	Cap Screw, Hex Hd., 1/4-20 x 1"
34	4641098	1	Starter Box Platform
35	2900138	4	Cap Screw, Hex Hd., 5/16-18 x 1"
36	4646049	1	Side Panel
37	2900144	4	Cap Screw, Hex Hd., 1/4-20 x 3/4"
38	4646006	2	Handle
39	2500636	2	Handle Grip
40	2900257	2	Lock Pin, T Handle, 3/8"
41	2900053	4	Rivet, 3/32" Dia.
42	4646003	1	Lifting Bar
43	2900248	2	Cap Screw, Hex Hd., 5/16-18 x 3"
44	1800169	1	Serial Number Plate, US
45	4646143	1	Hose Kit
46	1802755	1	Decal, Core Power CP15

CP15 EXL HYDRAULIC SCHEMATIC

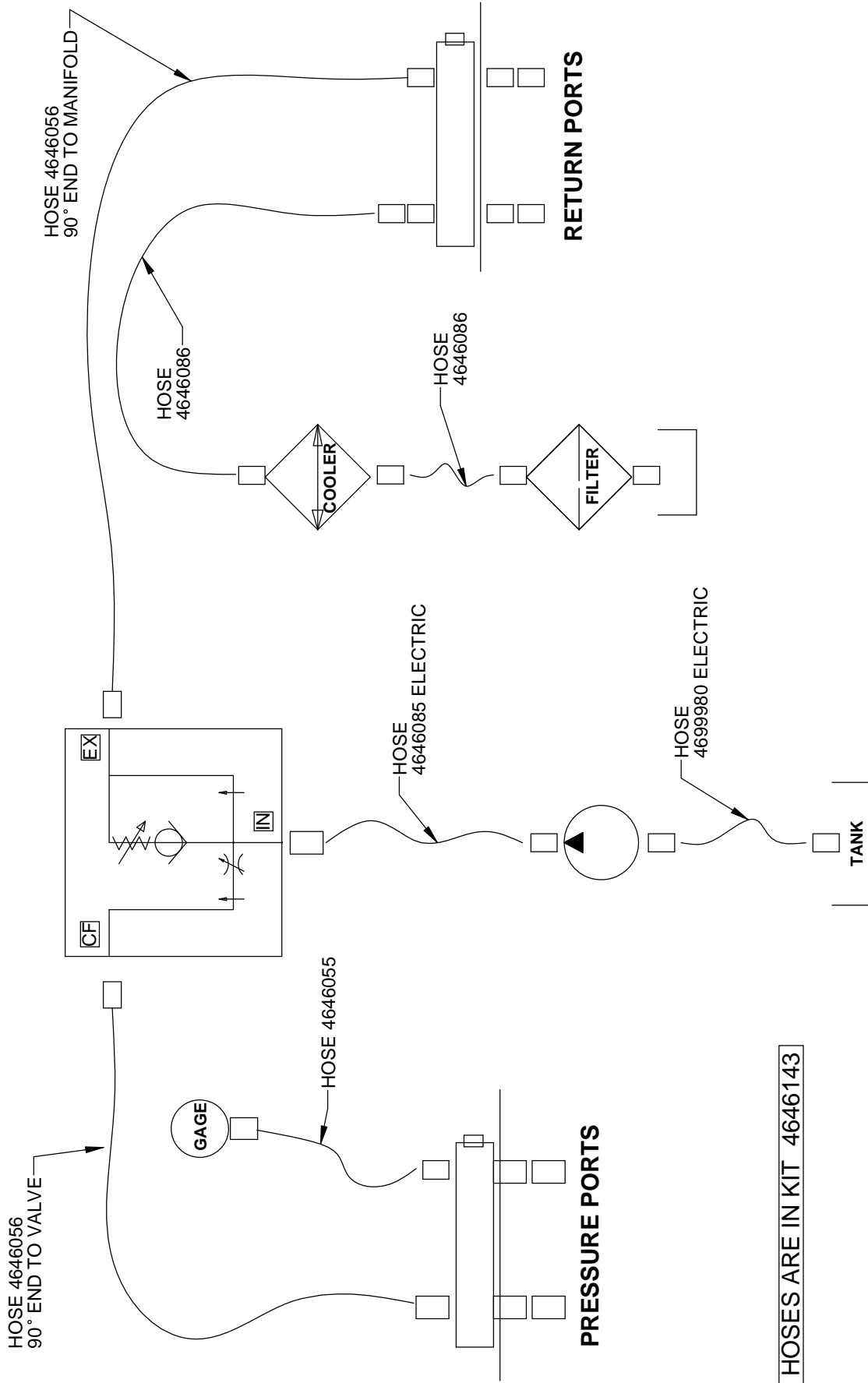

ALL HOSES ARE IN KIT 4646143

4646143 CP15EXL HOSE KIT

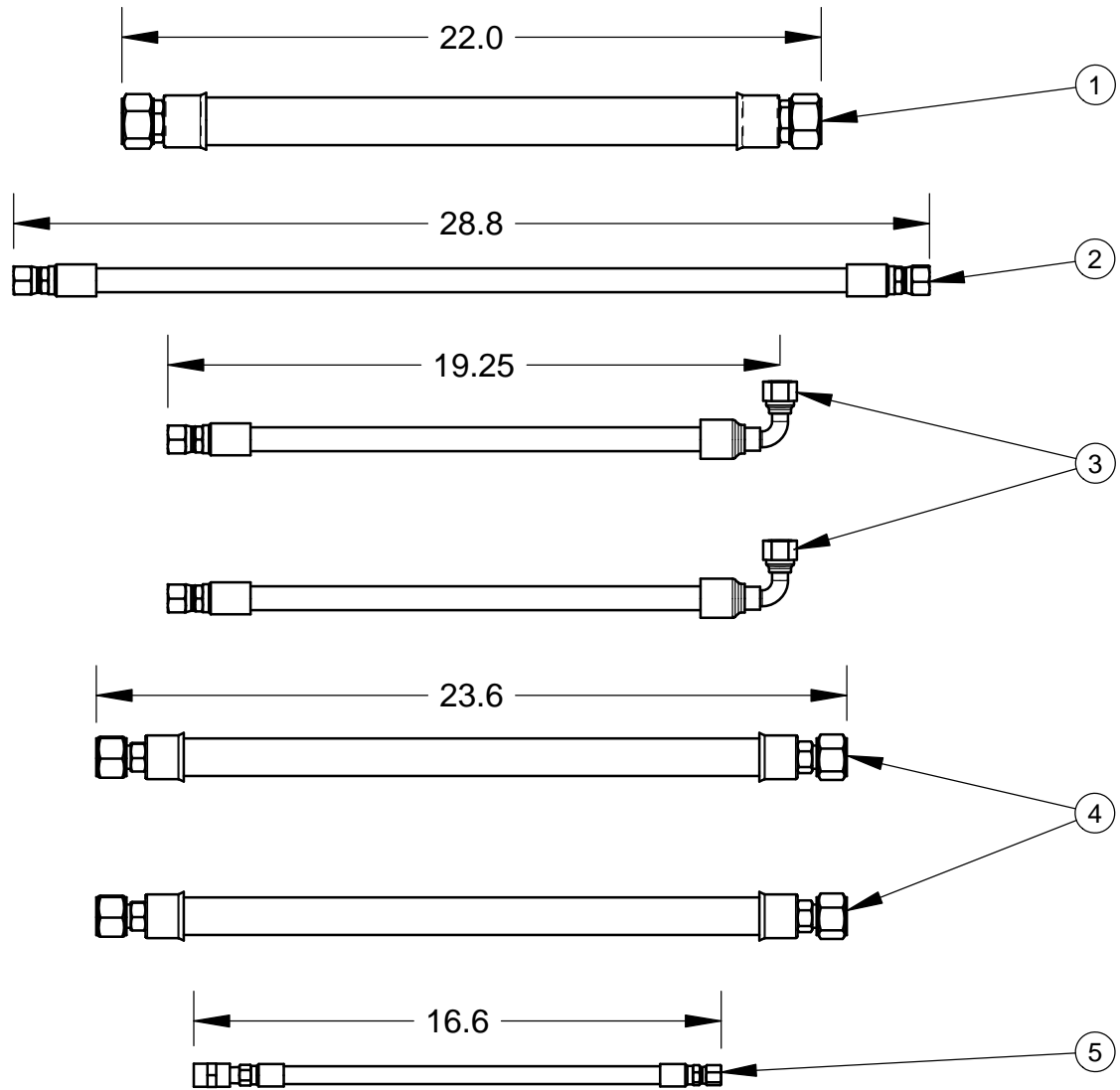

ITEM	PART NO.	QTY.	DESCRIPTION
1	4699980	1	Hose Assembly, 1 x 22"
	3202317	2	Fitting, 1" FJIC to 1" Hose Barb
	3205619	2	Crimp Shell, #16
2	4646085	1	Hose Assembly, 1/2"X 28-3/4"
	3200290	2	Fitting, 1/2" F. JIC to 1/2" Hose Crimp
3	4646056	2	Hose Assembly, 1/2" X 19-1/4"
	3200290	1	Fitting, 1/2" F. JIC to 1/2" Hose Crimp
	3200408	1	Elbow, 1/2" F. JIC to 1/2" Parkrimp 90 deg.
4	4646086	2	Hose Assembly, 3/4" x 23.6"
	3201989	2	Fitting, 3/4" F.JIC to 3/4" Hose Barb
	3202708	2	Crimp Shell, #12
5	4646055	1	Hose Assembly, 1/4" x 16.6"
	3200128	1	Fitting, 1/4" F. JIC to 1/4" Hose Crimp
	3200145	1	1/4 MPT - 1/4 Hose Crimp
	3201110	1	Coupling, 1/4" NPT

4646173 HYDRAULIC TANK ASSEMBLY

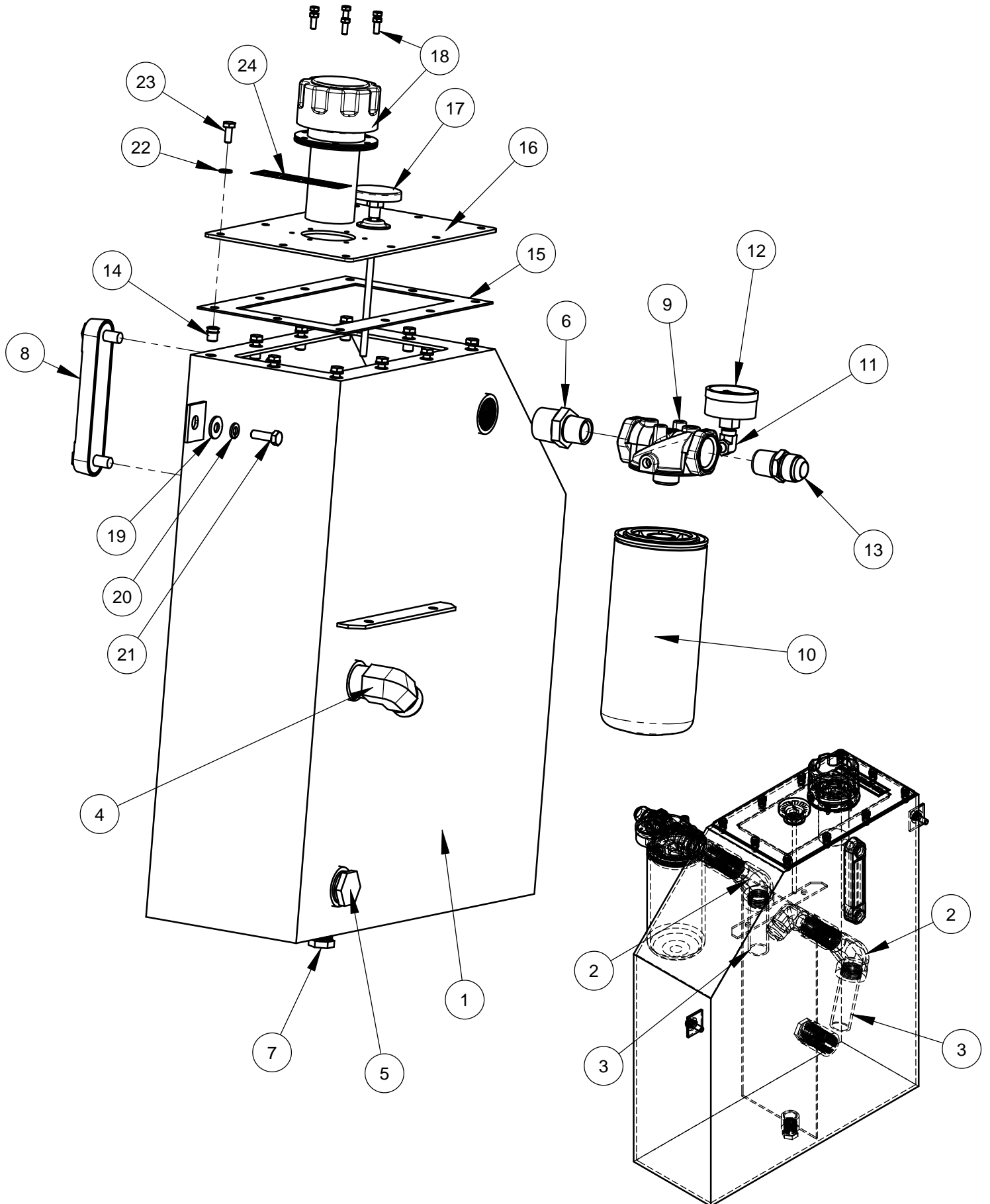

4646173 HYDRAULIC TANK ASSEMBLY

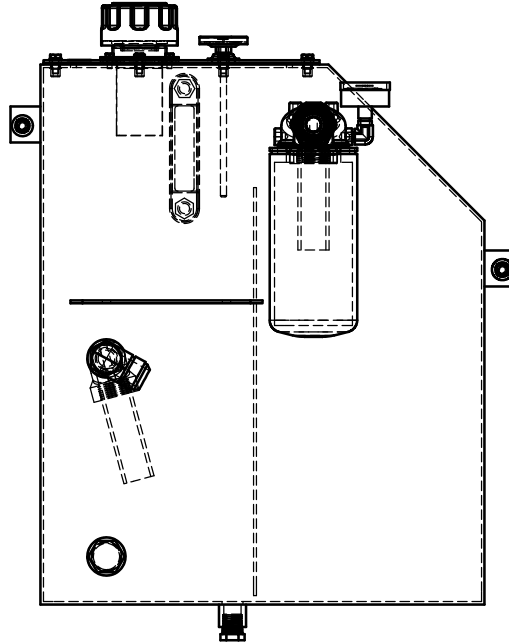

ITEM	PART NO.	QTY.	DESCRIPTION
1	4640120	1	Hydraulic Tank Weldment
2	3200409	2	Street Elbow, 1" NPT
3	3200427	2	Nipple, 1" NPT x 4", Schedule 40
4	3200289	1	Elbow, 1" M. Pipe to 1" M. JIC
5	3200288	1	Plug, 1" NPT
6	3200431	1	Nipple, 1"MPT - 3/4" MPT
7	3200160	1	Plug, 1/2-14 NPT
8	2400166	1	Sight Gauge, Liquid Level
9	2703290	1	Filter Head, 3/4" NPT
10	3201175	1	Hydraulic Filter Element
11	3200156	1	Street Elbow, 1/8" NPT
12	3200502	1	Gauge, Hydraulic Pressure
13	3200097	1	Adapter, 3/4" M. JIC to 3/4" M. Pipe
14	2900441	10	Rivet Nut, 1/4-20 Round
15	4646083	1	Gasket, Hyd Tank
16	4640121	1	Cover, Hydraulic Tank
17	2800459	1	Thermometer, 2", 0 - 200 F
18	2401305	1	Filler/Breather Cap (Top Mount)
	2900339	6	Cap Screw, Hex Hd., M5 x 12mm
19	2900567	2	Flat Washer, 5/16" USS
20	2900031	2	Lock Washer, 5/16" Split
21	2900138	2	Cap Screw, Hex Hd., 5/16-18 x 1"
22	2900024	10	Lock Washer, 1/4" Split
23	2900023	10	Cap Screw, Hex Hd., 1/4-20 x 5/8"
24	1800535	1	Decal, "Hydraulic Fluid Only"

4646174 CP15EXL PANEL ASSEMBLY

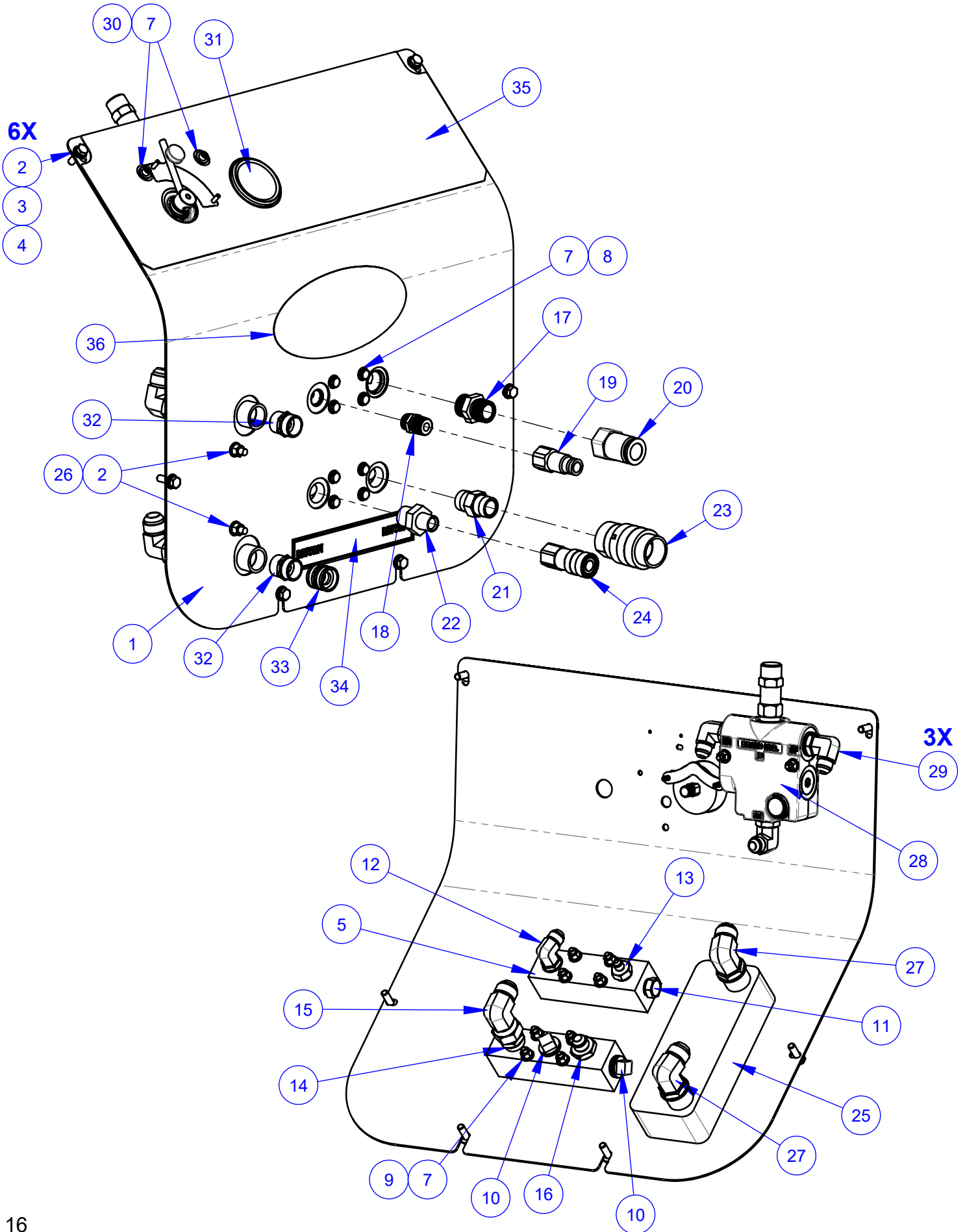

4646174 CP15EXL PANEL ASSEMBLY

ITEM	PART NO.	QTY.	DESCRIPTION
1	4646141	1	Instrument Panel
2	2900022	8	Flat Washer, 5/16" SAE
3	2900031	6	Lock Washer, 5/16" Split
4	2900138	6	Cap Screw, Hex Hd., 5/16-18 x 1"
5	4646102	1	Manifold, SAE O-Ring
6	4646101	1	Manifold, 3/4 NPT
7	2900009	20	Flat Washer, 1/4" SAE
8	2901001	8	Cap Screw, Hex Hd., 1/4-20 x 2-1/2"
9	2900010	10	Lock Nut, 1/4-20 Nylon
10	3200479	2	Plug, 3/4" NPT Square Head
11	3201434	1	Plug, 1/2" SAE O-Ring Hex
12	3200285	1	Elbow, 1/2" O-Ring to 1/2" M. JIC
13	3201291	1	Adapter, 1/2"M.O-Ring to 1/4" MJIC
14	3200097	1	Adapter, 3/4" M. JIC to 3/4" M. Pipe
15	3200417	1	Elbow, 3/4" F. JIC to 3/4" M. JIC
16	3201522	1	Adapter, 3/4" M. Pipe to 1/2" M. JIC
17	3200330	1	Adapter, 3/4" M. Pipe to 3/4" O-Ring
18	3200371	1	Adaptor, 1/2" MPT to 1/2" O-Ring
19	3200105	1	Nipple, 1/2" Q.D.
20	3200101	1	Nipple, 3/4" Quick Disconnect
21	3200137	1	Hex Nipple, 3/4" NPT
22	3200383	1	Nipple, Hex, 3/4" MPT TO 1/2" MPT
23	3200100	1	Coupler, 3/4" Quick Disconnect
24	3200104	1	Coupler, 1/2" Q.D.
25	2400256	1	Heat Exchanger
26	2900303	2	Lock Nut, M8-1.25 Nylon Insert
27	3200400	2	Elbow, 3/4" O-Ring to 3/4" Male JIC
28	3201654	1	Valve, Flow Control
29	3200366	3	Elbow, 5/8" O-Ring to 1/2" Male JIC, 90 Deg.
30	2900245	2	Cap Screw, Soc. Hd., 1/4-20 x 2-5/8"
31	3200250	1	Gauge, Hydraulic, 3000 PSI
32	3201659	2	Fitting, 3/4" M. Pipe to 3/4" M. Garden
33	3200177	1	Fitting, 3/4" F. Garden Union Swivel
34	1800536	1	"Return" Decal
35	1802764	1	Decal, Control Panel
36	1802620	1	DP Oval Logo Decal

4646032 STARTER BOX ASSEMBLY 208 - 460 VOLT

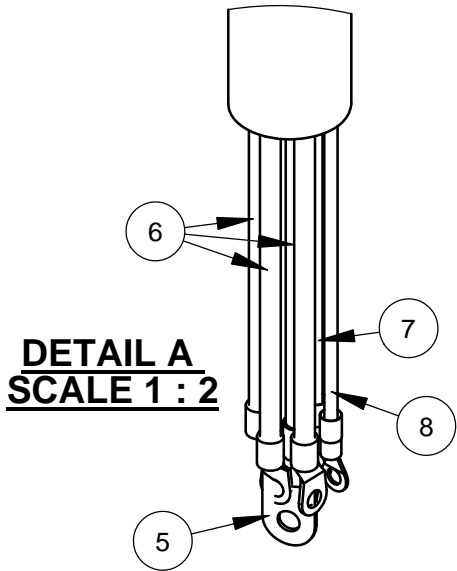
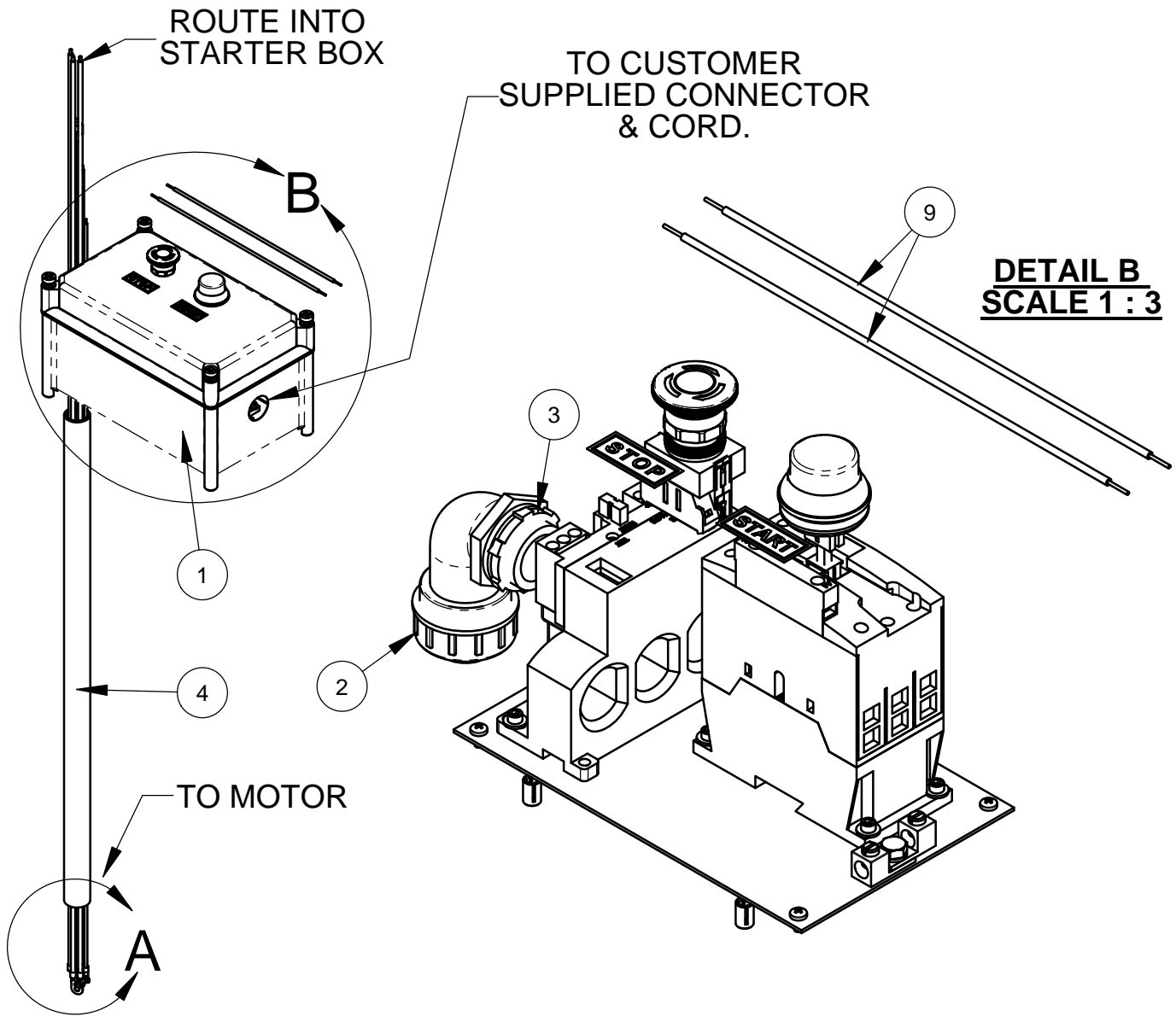

**DETAIL B
SCALE 1 : 3**

**DETAIL A
SCALE 1 : 2**

ITEM	PART NO.	QTY.	DESCRIPTION
1	4600276	1	Starter Box, 230-460V
2	2800898	1	Connector, 1", Sealtite, 90 Deg.
3	2800193	1	Lock Nut, 1"
4	4646144	1	Conduit, Seal Tite, 1" x 29"
5	4646145	1	Wire Assy., 6 Gage, Green, 50"
6	4646146	3	Wire Assy., 8 Gage, Black, 55"
7	4600165	1	Wire Assy., 14 Gage, Brown, 48-1/2"
8	4646148	1	Wire Assy., 14 Gage, Orange, 45"
9	4646128	2	Wire, 14 Gage, Orange, 12"

4646032 STARTER BOX ASSEMBLY 208 - 460 VOLT

SEE ALSO SCHEMATIC ON MOTOR NAME PLATE.

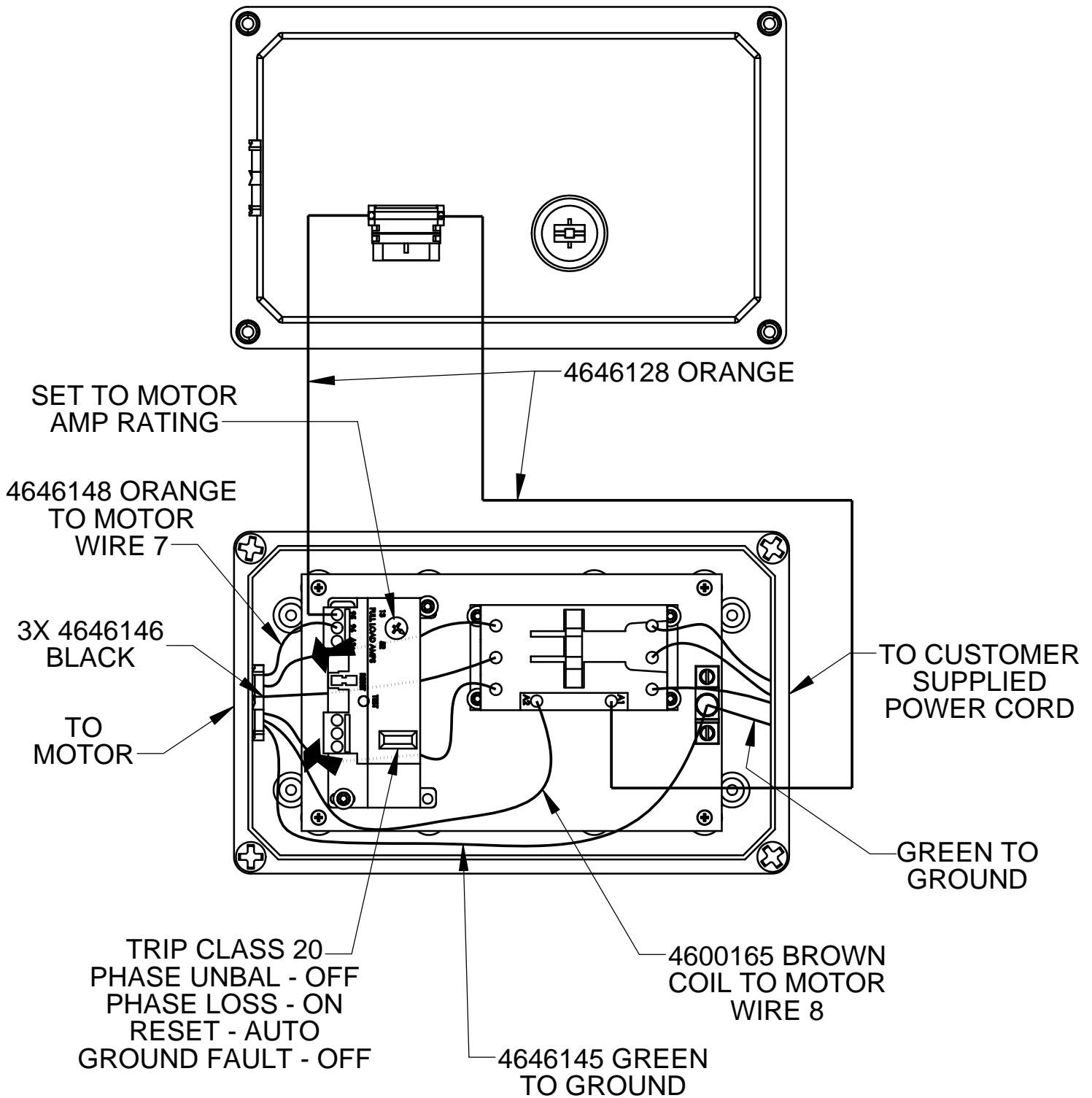

Intentionally Blank

4600276 STARTER BOX 230 - 460 VOLT

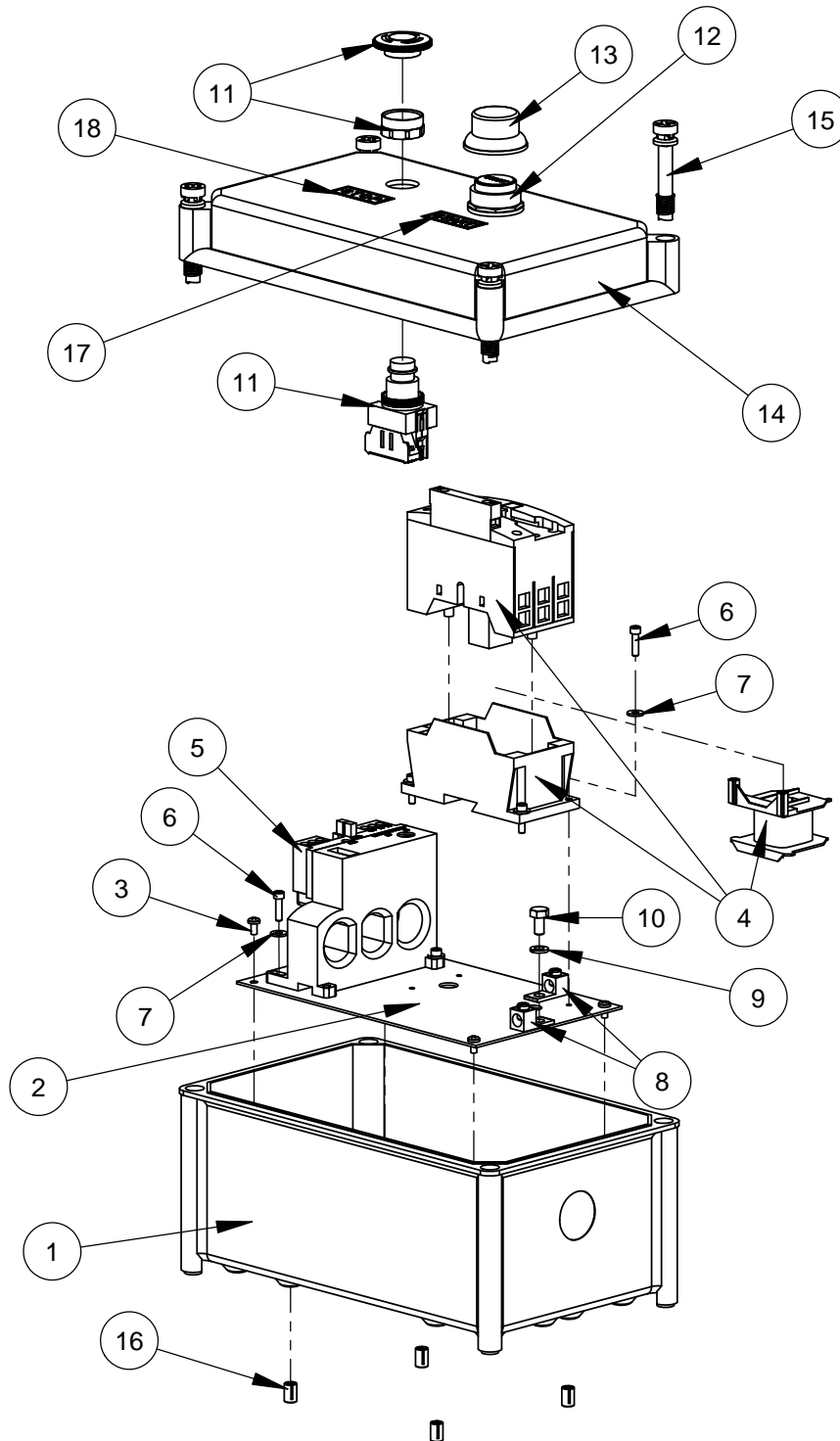

ITEM	PART NO.	QTY.	DESCRIPTION
1	6040300G	1	Electrical Box Base
2	6040598	1	Sub-plate
3	2900676	4	Machine Screw, Pan Hd., M4-0.7 x 8mm
4	2801704	1	Contactor, 220-240V (includes coil)
	2801265	1	Replacement Coil, 220-240V
5	2800899	1	Overload Relay, 13-52 Amp
6	2901827	6	Cap Screw, Soc. Hd., #8-32 x 5/8"
7	2901437	6	Flat Washer, #10
8	2800315	2	Grounding Lug
9	2900024	1	Lock Washer, 1/4" Split

ITEM	PART NO.	QTY.	DESCRIPTION
10	2901891	1	Cap Screw, Hex Hd., 1/4-28 x 1/2"
11	2801636	1	E-Stop Switch, 600V, NC
12	4600166	1	Start Switch
13	2800222	1	Clear Protective Boot
14	6048339	1	Cover, Electric Box, 2 Hole
15	2701414	4	Fastener, Electrical Box Top
16	2901332	4	1/4-20 Threaded Insert
17	1801638	1	Decal, Start
18	1801639	1	Decal, Stop

4646074 STARTER BOX ASSEMBLY, 550-600 VOLT

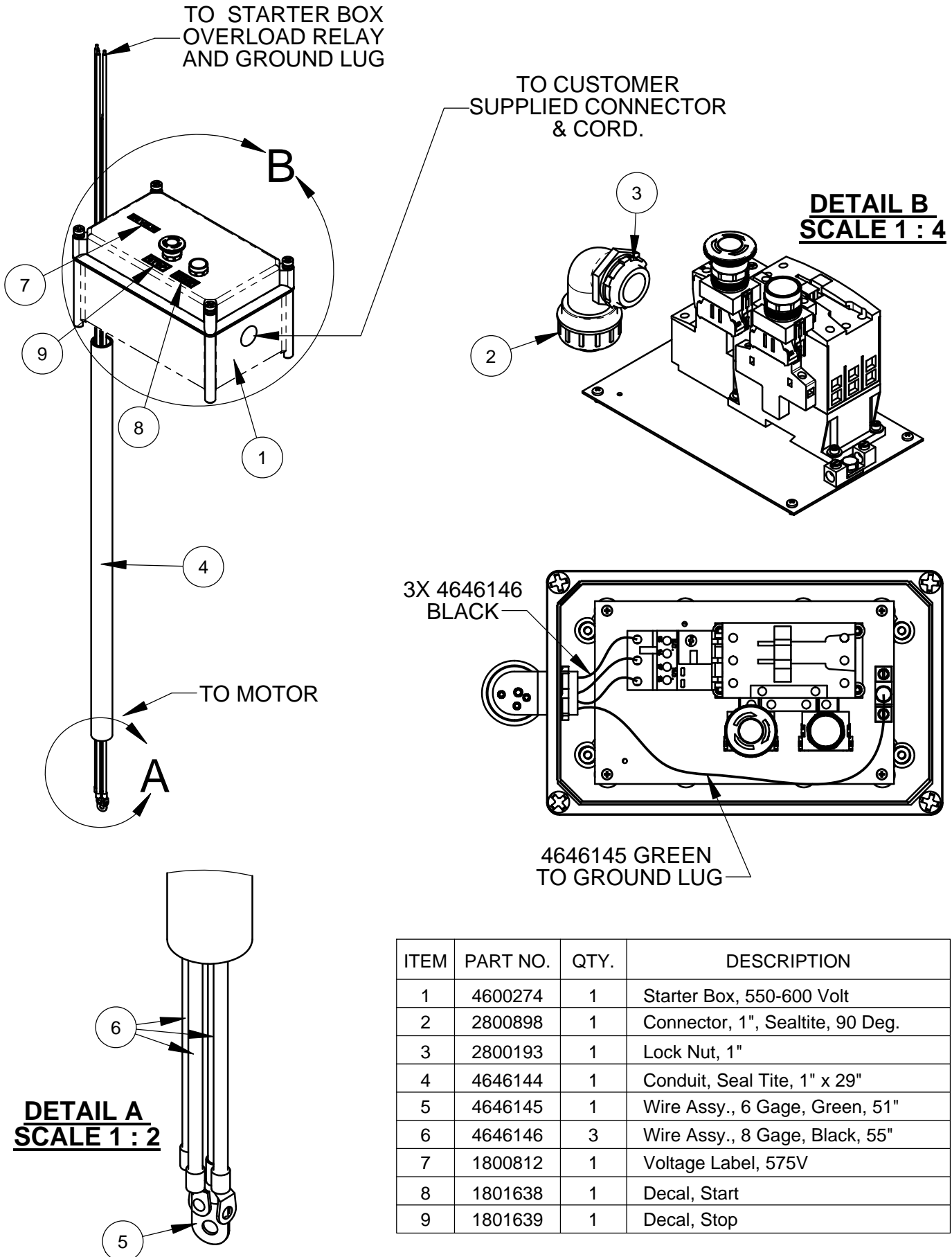

ITEM	PART NO.	QTY.	DESCRIPTION
1	4600274	1	Starter Box, 550-600 Volt
2	2800898	1	Connector, 1", SealTite, 90 Deg.
3	2800193	1	Lock Nut, 1"
4	4646144	1	Conduit, Seal Tite, 1" x 29"
5	4646145	1	Wire Assy., 6 Gage, Green, 51"
6	4646146	3	Wire Assy., 8 Gage, Black, 55"
7	1800812	1	Voltage Label, 575V
8	1801638	1	Decal, Start
9	1801639	1	Decal, Stop

4600274 STARTER BOX, 550-600 VOLT

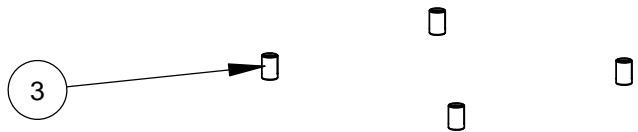
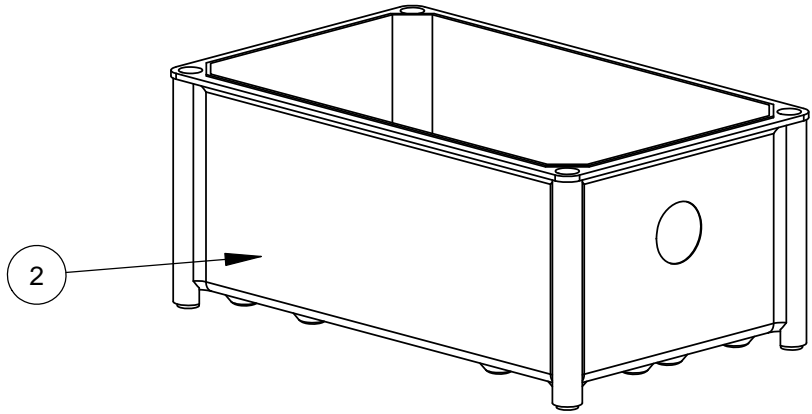
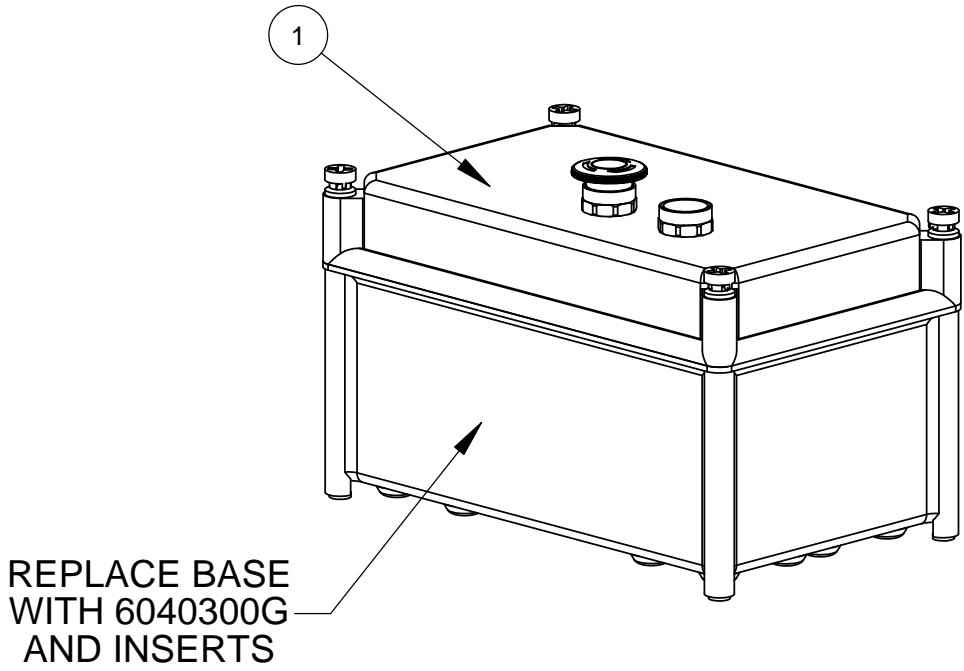

ITEM	PART NO.	QTY.	DESCRIPTION
1	2801033	1	Starter Box, 550-600V
2	6040300G	1	Electrical Box Base
3	2901332	4	1/4-20 Threaded Insert

2801033 STARTER BOX, 550-600 VOLT

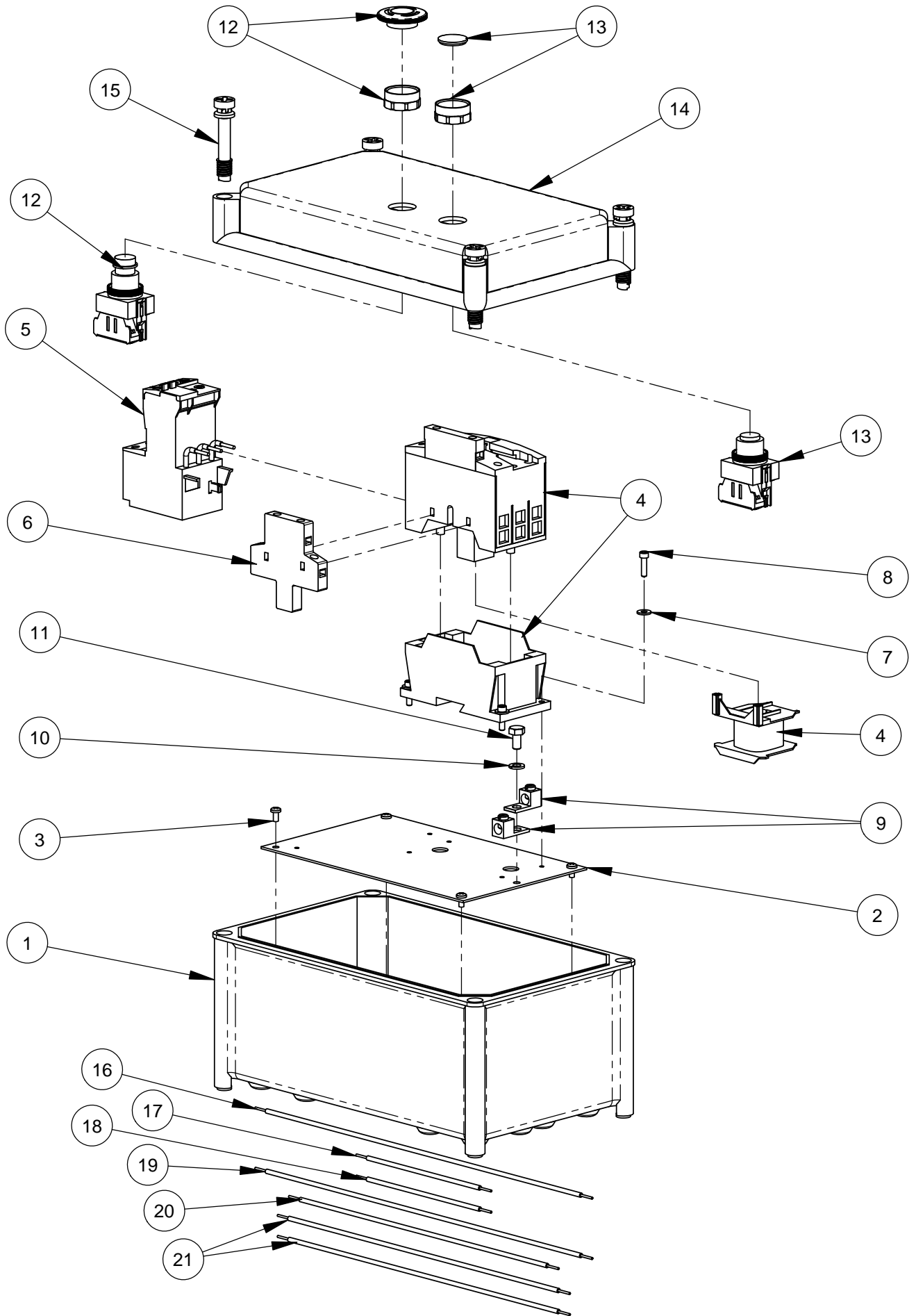

2801033 STARTER BOX, 550-600 VOLT

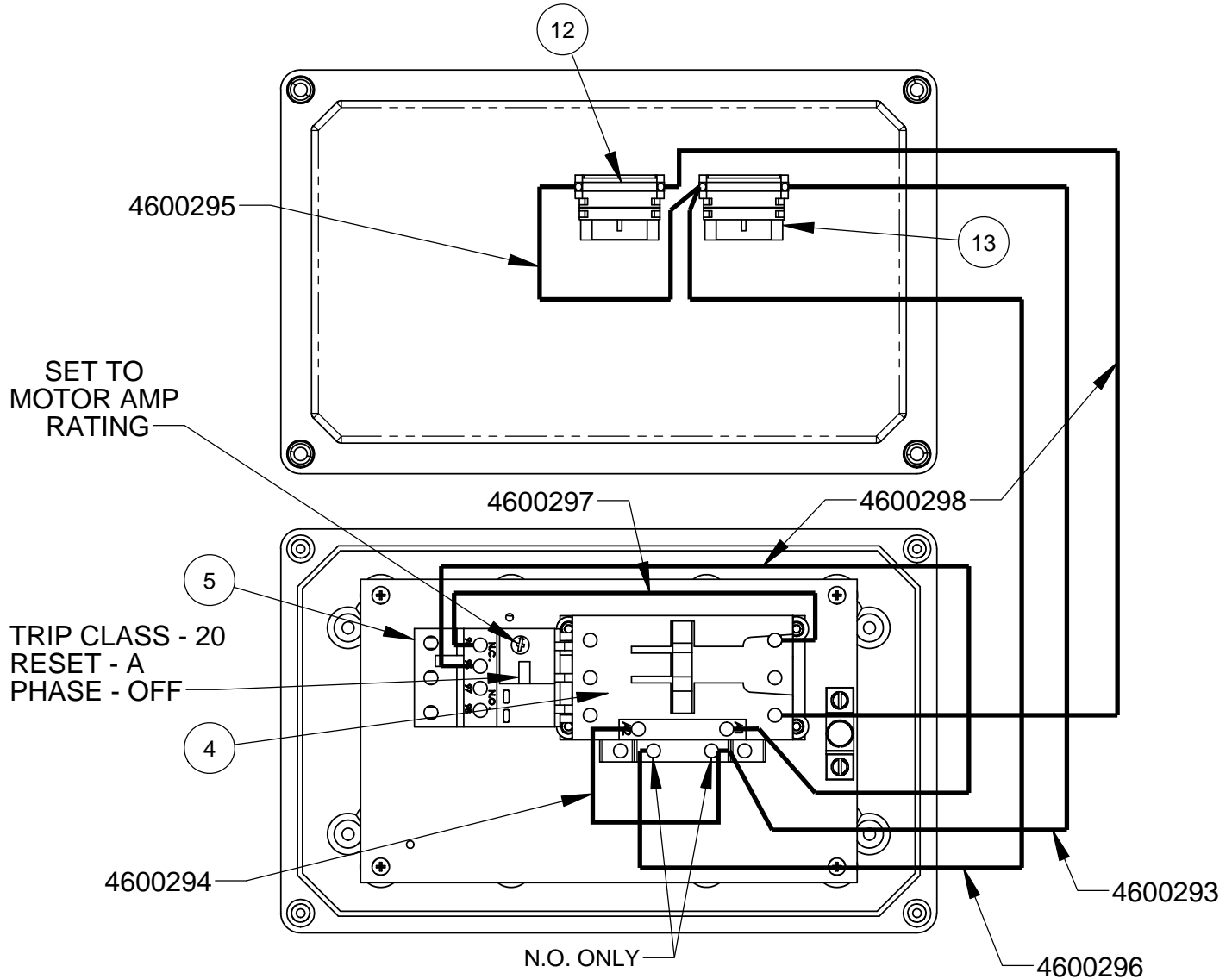

ITEM	PART NO.	QTY.	DESCRIPTION	ITEM	PART NO.	QTY.	DESCRIPTION
1	2702419	1	Electrical Box (Base)	11	2901891	1	Cap Screw, Hex Hd., 1/4-28 x 1/2"
2	6040598	1	Sub-plate	12	2801636	1	E-Stop Switch, 600V, NC
3	2900676	4	Machine Screw, Pan Hd., M4-0.7 x 8mm	13	2801639	1	Pushbutton, N.O., 600V
4	2801709	1	Contactor, 550-600V (includes coil)	14	6048296	1	Electric Box Cover, 2 Hole
	2801267	1	Replacement Coil, 550-600V	15	2701414	4	Fastener, Electrical Box Top
5	2801699	1	Overload Relay, 9-45 AMP	16	4600293	1	Wire, 14 Gage, Yellow, 15"
6	2801676	1	Auxiliary Contacts, 1NO-NC	17	4600294	1	Wire, 14 Gage, Yellow, 6"
7	2901437	4	Flat Washer, #10	18	4600295	1	Wire, 14 Gage, Black, 6"
8	2901827	4	Cap Screw, Soc. Hd., #8-32 x 5/8"	19	4600296	1	Wire, 14 Gage, Black, 15"
9	2800315	2	Grounding Lug	20	4600297	1	Wire, 14 Gage, Red, 12"
10	2900024	1	Lock Washer, 1/4" Split	21	4600298	2	Wire, 14 Gage, Red, 13"

4400262 TOOL TRAY OPTION, ELECTRIC UNITS

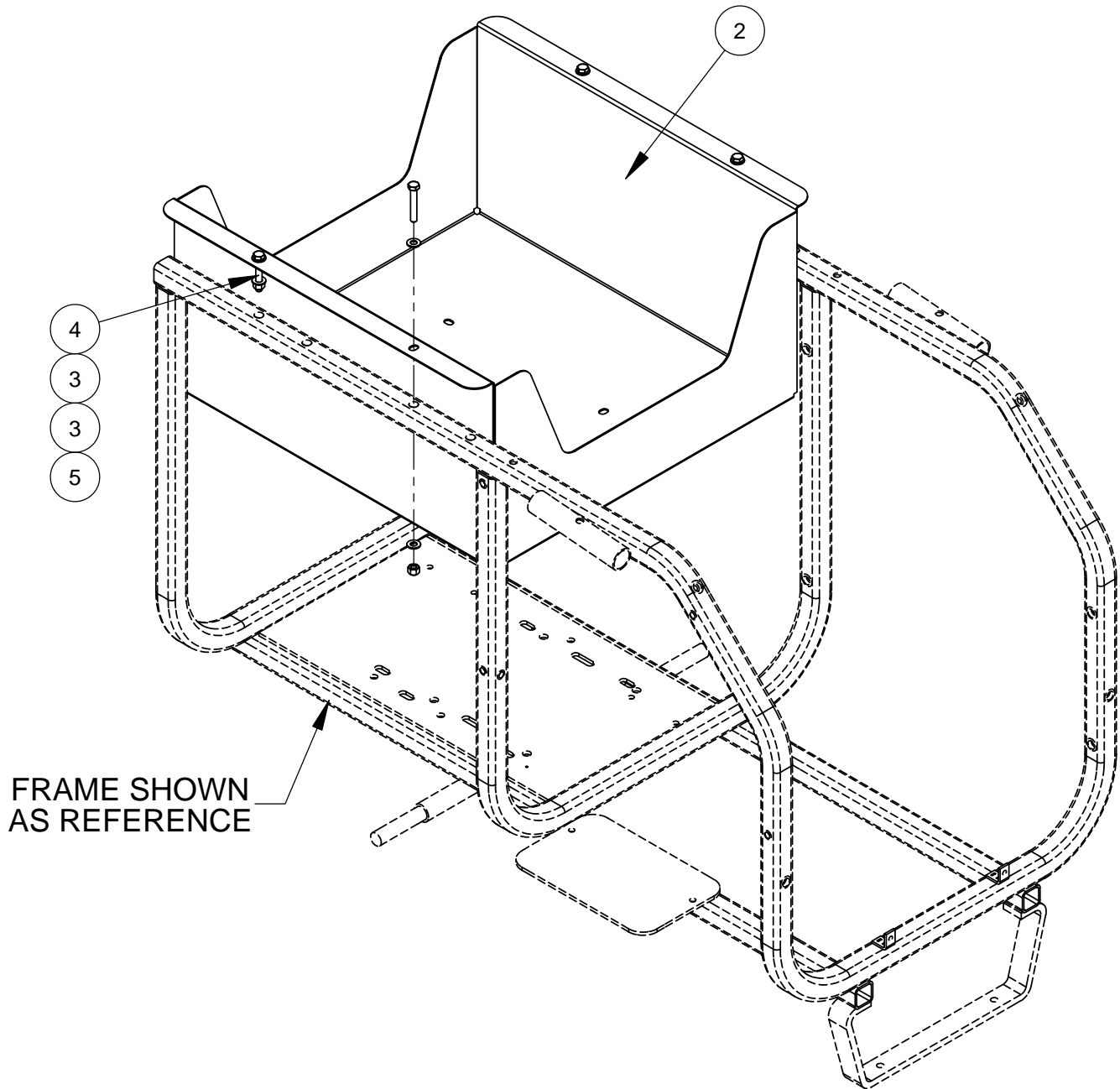

ITEM	PART NO.	QTY.	DESCRIPTION
1	4646156	1	CP-XL Frame Assembly
2	4400207	1	Tool Tray
3	2900022	8	Flat Washer, 5/16" SAE
4	2900494	4	Cap Screw, Hex Hd., 5/16-18 x 2"
5	2900039	4	Lock Nut, 5/16-18 Nylon

4641172 WHEEL UPGRADE KIT

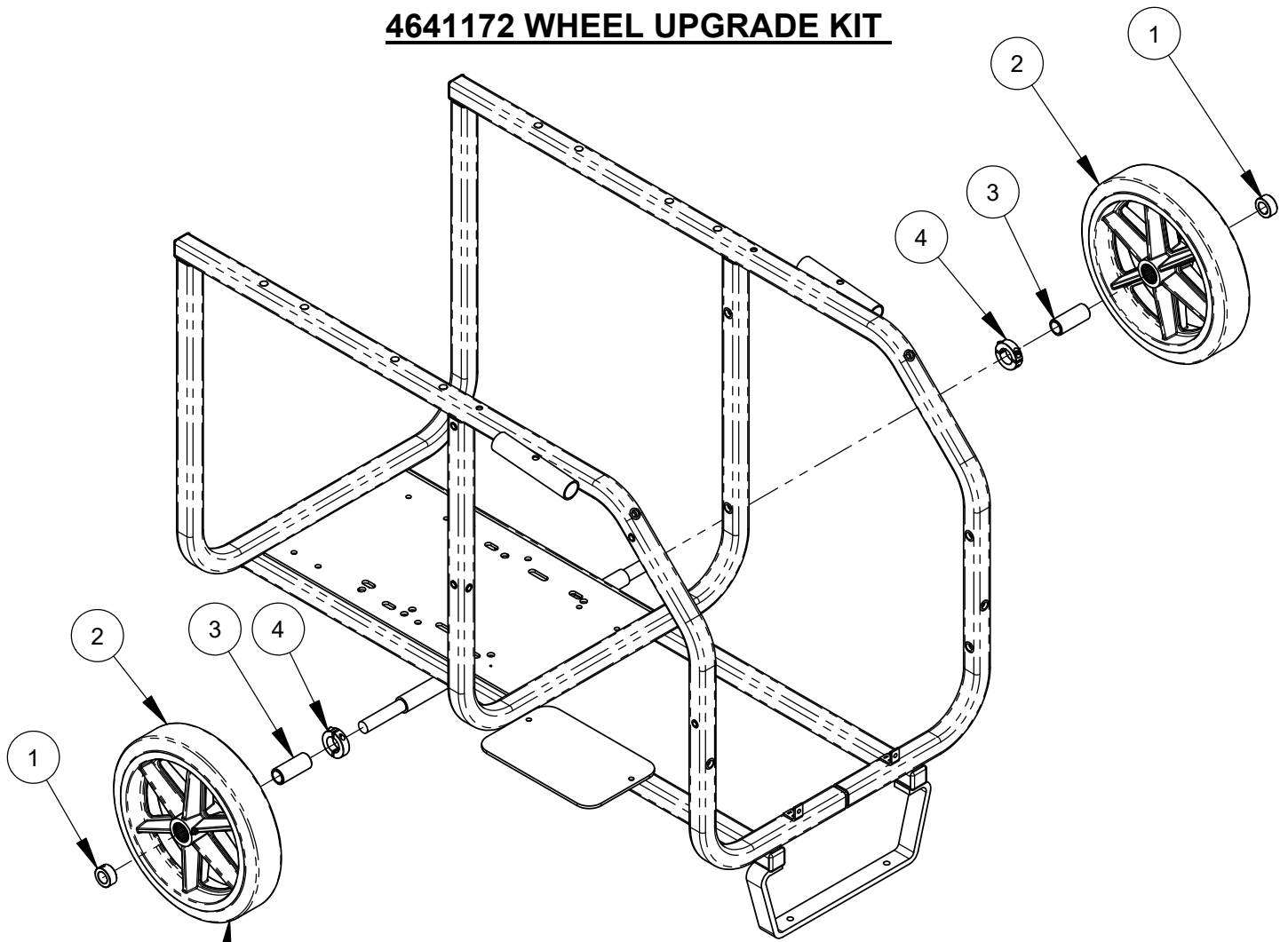

NOTE: WHEEL RESTS ON BOTH AXLE AND BUSHING (6041174)

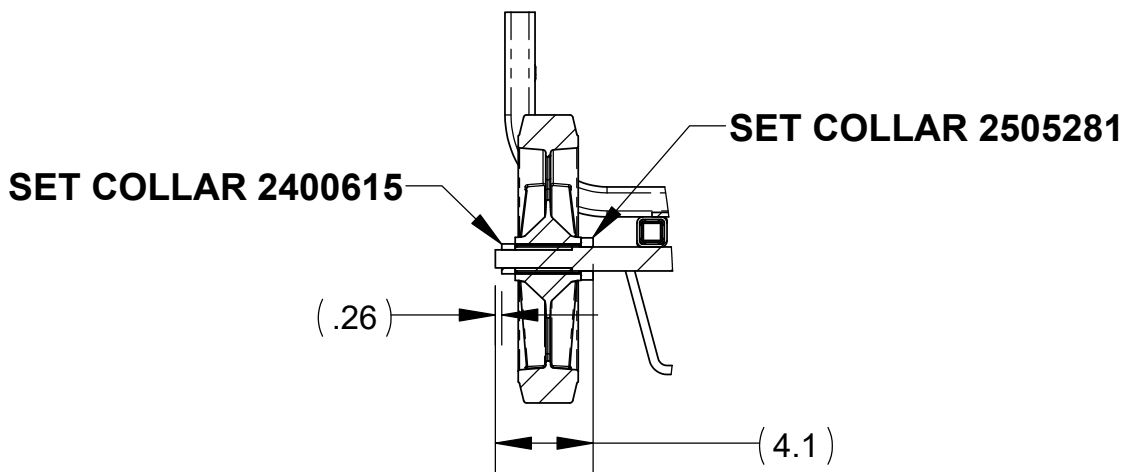

ITEM	PART NO.	QTY.	DESCRIPTION
1	2400615	2	Set Collar, 3/4"
2	2505179	2	Wheel 12" X 2-3/4" X 1"
3	6011774	2	Bushing, .75 x 1.00 x 2.38L
4	2505281	2	Set Collar, 1" ID (2 Piece)

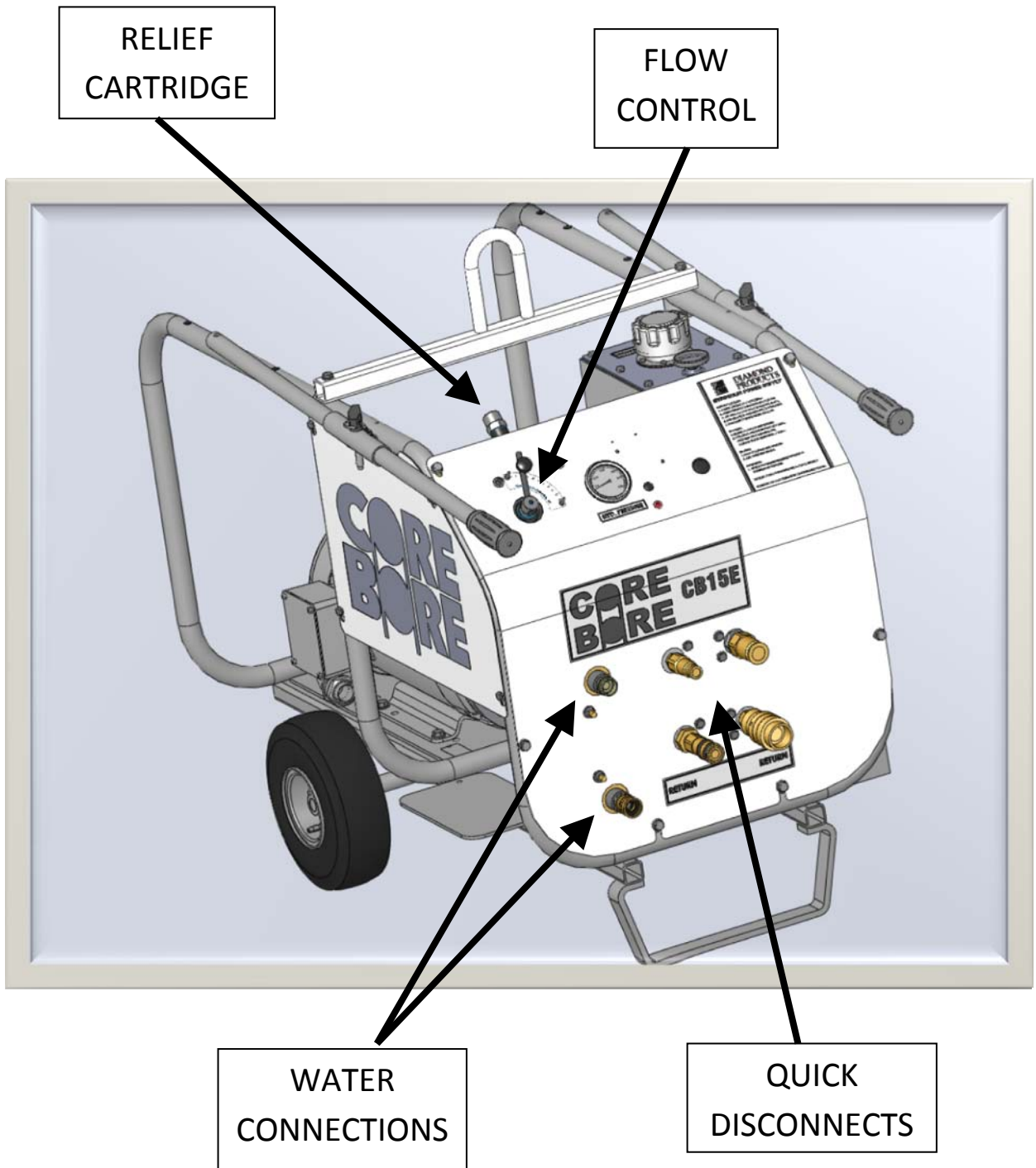

GENERAL SAFETY PRECAUTIONS

WARNING: Do not operate power unit without reading this entire manual and the engine operation manual first. Keep manuals with power unit at all times for reference.

This manual describes the operating procedures, care, maintenance, adjustments, and safety precautions for proper use of this machine. This equipment is intended for industrial applications by experienced operators. It is to be operated in conformance with applicable federal, state, and local codes or regulations pertaining to safety, air pollution, noise, etc.

Tool operators and maintenance personnel must always comply with the safety precautions given in this manual and on the stickers and tags attached to the equipment.

These safety precautions are given for your safety. Review them carefully before operating the tool and before performing general maintenance or repairs.

Supervising personnel should develop additional precautions relating to the specific work area and local safety regulations.

In addition to this manual, read and understand safety and operating instructions in the Engine Operation Manual furnished with the Power Unit in addition to this manual.

- Establish a training program for all operators to ensure safe operation.
- Do not operate the power unit unless thoroughly trained or under the supervision of an instructor.
- Do not inspect or clean the power unit while it is running.
- Always use hoses and fittings rated at a minimum 2100 psi (145 bar) with a 4 to 1 safety factor for pressure lines.
- Be sure all hose connections are tight.
- Make sure all hoses are connected for correct flow direction to and from the tool being used.
- Do not inspect hoses and fittings for leaks by using bare hands. "Pin-hole" pressure leaks can penetrate the skin.
- Do not operate a damaged or improperly adjusted power unit.
- Never wear loose clothing that can get entangled in the working parts of the power unit.
- Keep all parts of your body away from the working parts of the power unit.
- Always wear appropriate safety equipment such as goggles, ear protection, head protection and safety shoes. Certain tools used in conjunction with the power unit may require other safety equipment such as breathing filters.

- Do not operate the power unit if a gasoline odor is present.
- Do not use flammable solvents around the power unit motor.
- Do not operate the power unit within 3 ft. (1 meter) of buildings or flammable objects.
- Allow the motor to cool before storing the unit in an enclosed area.
- To avoid personal injury or equipment damage, all tool repair, maintenance and service must only be performed by authorized and properly trained personnel.

IMPORTANT: The red stop button at the top of the starter box will immediately stop the motor. Hydraulic pressure and flow will go to zero. This button must be in the out position to start the unit.

DANGER: Improper use or alteration of this equipment may be extremely hazardous.

SAFETY SYMBOLS

Safety symbols are used to emphasize actions which could result in a life-threatening situation, bodily injury, or damage to equipment.

Always observe safety symbols. They are included for your safety and for the protection of the tool.

! DANGER !

This safety symbol may appear on the tool. It is used to alert the operator of an action that could place him/her or others in a life threatening situation.

!WARNING: !

This safety symbol appears in these instructions to identify an action that could cause bodily injury to the operator or to other threatening situation.

! IMPORTANT!

This safety symbol appears in these instructions to identify an action or condition that could result in damage to the tool or other equipment.

DESCRIPTION AND SPECIFICATIONS

Pump: Gear, pump rotation is clockwise (motor is CCW).

Maximum GPM: 12-3/4 GPM (48.2L/M). Flow will decrease as pressure increases.

Hydraulic Fluid Tank Capacity: 11 gallons (41.6Liters)

Hose Couplings: Bruning quick disconnect, 3/4 inch & 1/2 inch

Relief Pressure: Factory set at 2100 PSI/145 Bar (at valve outlet port). Adjustable to 750 PSI/52 Bar, CURRENT LIMITED TO 2100 PSI.

Electric Motor: Baldor 15 HP, C Face, 3450 RPM, 208-460 Volts, 575 Volts (Canada only).

This unit is compatible with most hydraulically driven sawing and drilling components. The system may not be compatible with components of some manufacturers.

The power unit was inspected and operated before shipment and should not require any additional adjustments prior to its initial use.

Hydraulic Fluid: The reservoir of the hydraulic power unit must be full prior to start-up. The use of high quality petroleum based hydraulic oil with the following properties is recommended:

- Anti-wear
- Low foaming
- Rust and oxidation inhibitors
- Wide temperature range
- Fluid viscosity: 8-1000 Centistokes (52-4600 SUS). The unit is shipped with an ISO 46 Viscosity grade (8Cs/52SUS @ 212F/100C and 46Cs/210SUS @ 104F/40C).

The oil must be kept free of contamination to avoid damage to system components. The strainer in the fill cap must always be in place when adding oil. Quick disconnects must be cleaned before connections are made.

Control Valve: The pressure compensated flow control valve on this unit directs excess flow to tank, not over relief. This conserves horsepower and reduces heat buildup. Flow settings are: 0-2, all flow routed to tank; 2-8, adjustable range, 8-10 full flow.

Relief pressure can be adjusted by removing the cap at the top of the main control and using an Allen wrench to adjust the relief cartridge. The relief can be set

as low as 750 psi; do not exceed 2100 psi. To adjust, the flow control must be set at 10 and no tool should be attached. This will force all flow over relief. Securely replace the cap as oil seepage will occur through the relief cartridge. The relief is factory set at 2100 psi (electric) and should rarely need adjustment.

Hydraulic Oil Cooler: The power unit is equipped with a brazed plate style oil cooler. Water should be passed through the cooler before being used for dust control or blade & bit cooling. Some tools will automatically shut off water flow when not actively cutting, drilling, etc. This may result in higher oil temperatures if the power unit continues to run for long periods without cooling water.

IMPORTANT: If there is a risk of frost the water must be drained from the cooler to prevent damage by freezing.

HOSES: Large diameters and short lengths are preferred and offer the highest system efficiency. If one is operating 50 ft (15.2M) from the power source, there is also a 50 ft (15.2M) return for a 100 ft (35.5M) total hose length. With 12 GPM and oil at 100 deg. F (37.8C), this could result in a 300 psi (20.6 Bar) pressure loss with ½” hose and a 100 psi (6.9 Bar) loss with 5/8” hose. Pressure loss will change dramatically with oil temperature.

OPERATING INSTRUCTIONS

Operator Responsibilities

It is the operator’s responsibility to use this unit and any attached tools under safe working conditions and to follow proper safety procedures for themselves, co-workers, observers, and the public at large. The operator must be aware of the machine’s capabilities and limitations and follow the safety precautions in each section of this manual. Periodic maintenance is required, in accordance with the instructions herein, to promote safe and reliable operations.

WARNING: Keep bystanders out of the immediate work area.

Wear approved:

- Safety glasses
- Ear protection
- Hard hat
- Gloves
- Safety shoes
- Any other protective equipment required for compliance with standard safety practices or federal, state, and local codes and regulations

Hose Connections: It is best to connect the hoses to the unit before starting as even very low residual pressure can make hose installation more difficult. Push couplings together until you hear it click. Turn locking ring of coupling to the secured position.

Starting Procedure:

- Set the flow control valve to zero.
- Be certain the stop switch has been pulled out.
- Be certain the unit is connected to the proper voltage and a proper gage power cord is used.
- Press the start button at the top of the starter box.

Heating Cold Oil: Forcing the oil over relief will quickly increase the oil temperature. With no tool connected to the unit, move the valve setting toward 10. This will force an increasing percentage of oil over relief. Heat cold oil to room temperature or ~100F/38C maximum. Cold oil greatly increases pressure loss in hoses and fittings and may affect tool operation.

Maintaining Oil Temperature: With an ample water supply, it is unlikely overheating will be an issue except in the most extreme ambient temperatures. To force high oil temperatures down, run the unit with the flow control set to zero. This unloads the unit yet circulates oil through the cooling system. The rate of cooling will depend on the ambient temperature and how much water is being passed through the cooler.

Some control valves at the external tool may create backpressure and heat even when off. It is best to set the flow control to zero or shut the power unit down to avoid heating and conserve energy.

IMPORTANT: Monitor the thermometer at the top of the hydraulic tank. Maximum recommended oil temperature is 180 degrees Fahrenheit (82 deg C).

Shutting Down:

- Shift the flow control valve to zero to unload the system.
- Press the stop button at the top of the starter box.

OPERATING DRIVEN EQUIPMENT

The operator must know the hydraulic requirements and limitations of the driven equipment and the appropriate adjustments must be made on the controls. The introduction of other control devices may cause system heating or may render the system inoperative.

IMPORTANT: This power unit is equipped with a positive displacement gear pump. All tools must be equipped with a control valve that allows flow directly to return ports when not in use. Blocking oil flow or abruptly disconnecting the tool can send flow over relief and potentially overheat the system.

Instructions supplied with the driven equipment must be followed to ensure correct connection and operation of each individual piece of equipment. Equipment supplied by Diamond Products will be capable of being connected correctly and will be compatible with this power unit, providing neither has been modified from original factory configuration. With equipment of other manufacturers, it will be necessary to determine the following:

- Correct direction of flow through the equipment.
- Correct pressure and flow required by the equipment.

- Compatibility of any valves or circuitry and quick disconnects. Some hand-held equipment uses a trigger control, which is operated frequently. These valves must be of the open center type for correct operation.

IMPORTANT: The quick disconnects must be clean when connecting hoses and devices. Dirty connections may result in contamination and premature failure of system or tool components.

MAINTENANCE INSTRUCTIONS

- Oil Filter: change the filter when indicated by the gage at the filter.
- Oil Change: establishing an oil analysis program is the preferred method of determining oil condition and when to change it. If the oil is kept clean, dry, and operated at moderate temperatures, it can last for several years. With no analysis program an oil change every 200 hours is recommended. See the section Hydraulic Fluid for specifications. A ½" pipe thread oil drain port is at the bottom of the hydraulic tank.
- Inspect hoses, couplings, and fittings daily for leaks, tighten as required. Clean quick disconnects frequently. Replace any leaking or defective components immediately.
- Check hydraulic oil level daily. Fill tank to upper end of sight tube with unit off.
- Grease the wheel bearings annually.

TROUBLESHOOTING

PROBLEM	POSSIBLE SOLUTIONS
Electric motor will not start.	1) Pull out stop button on starter box. 2) Confirm proper voltage.
Running with no pressure.	The motor may be running backwards, should be counter clockwise. Reverse any two of the 3 power wires coming into the starter box.
System builds high pressure with flow control valve set to zero.	Contamination may have plugged an orifice in the CF port of the flow valve. Detach the valve from the front panel and remove the fitting from the CF port. A .015" orifice should be visible at the bottom of the port. Push a fine wire through the orifice and re-install.

Keep this manual and the engine manual readily available at all times for reference.

Corporate Office

333 Prospect St., Elyria, Ohio 44035
(216) 323-4616 • Fax: (216) 323-8689
Customer Service: 1-800-321-5336
Customer Service Fax: 1-800-634-4035

Intentionally Blank

EQUIPMENT AND PARTS WARRANTY

Diamond Products warrants all equipment manufactured by it against defects in workmanship or materials for a period of one (1) year from the date of shipment to Customer.

The responsibility of Diamond Products under this Warranty is limited to replacement or repair of defective parts at Diamond Products' Elyria, Ohio factory, or at a point designated by it, of such parts as shall appear to us upon inspection at such parts, to have been defective in material or workmanship, with expense for transportation and labor borne by Customer.

In no event shall Diamond Products be liable for consequential or incidental damages arising out of the failure of any Product to operate properly.

Integral units such as engines, electric motors, batteries, transmissions, etc., are excluded from this Warranty and are subject to the prime manufacturer's warranty.

THIS WARRANTY IS IN LIEU OF ALL OTHER WARRANTIES, EXPRESSED OR IMPLIED, AND ALL SUCH OTHER WARRANTIES ARE HEREBY DISCLAIMED.



333 Prospect Street, Elyria, Ohio 44035
(440) 323-4616 • (800) 321-5336 • Fax (800) 634-4035
www.diamondproducts.com