

**DIAMOND  
PRODUCTS**

**PRO SERIES FLUSH CUT HYDRAULIC HAND SAW  
5800857 25.00"-1.61IN<sup>3</sup> (15GPM)**



**PARTS MANUAL  
NOVEMBER 2014  
PART NUMBER 1803024  
[WWW.DIAMONDPRODUCTS.COM](http://WWW.DIAMONDPRODUCTS.COM)**



# Table Of Contents

<b>Saw Dimensions.....</b>	<b>1</b>
<b>Blade Flange.....</b>	<b>2</b>
<b>General Safety.....</b>	<b>3</b>
<b>Hand Saw Operation.....</b>	<b>4</b>
<b>Saw Parts List.....</b>	<b>5-6</b>
<b>Bearing Block Assembly.....</b>	<b>7</b>
<b>Metro Valve Assembly.....</b>	<b>8</b>
<b>Trigger Assembly.....</b>	<b>9</b>
<b>Hydraulic Motor.....</b>	<b>10</b>
<b>Saw Maintenance &amp; Record.....</b>	<b>12</b>
<b>Warranty Info.....</b>	<b>13</b>

# Pro Series Flush Cut Hydraulic Hand Saw

**5800857 - 25.00" 1.61in<sup>3</sup> (15GPM Rated)**

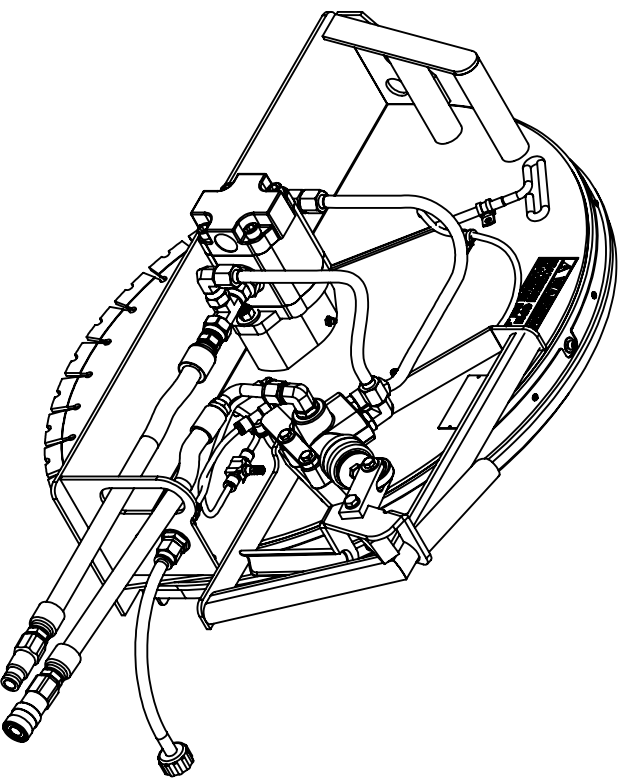
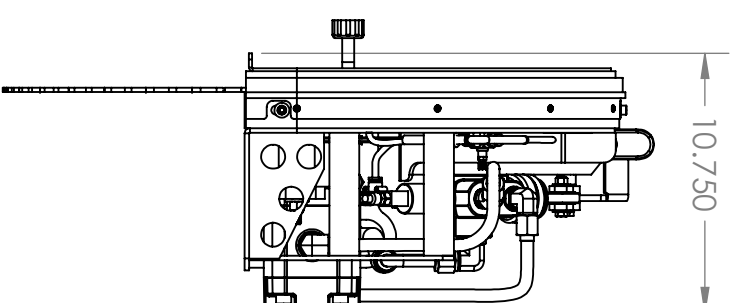
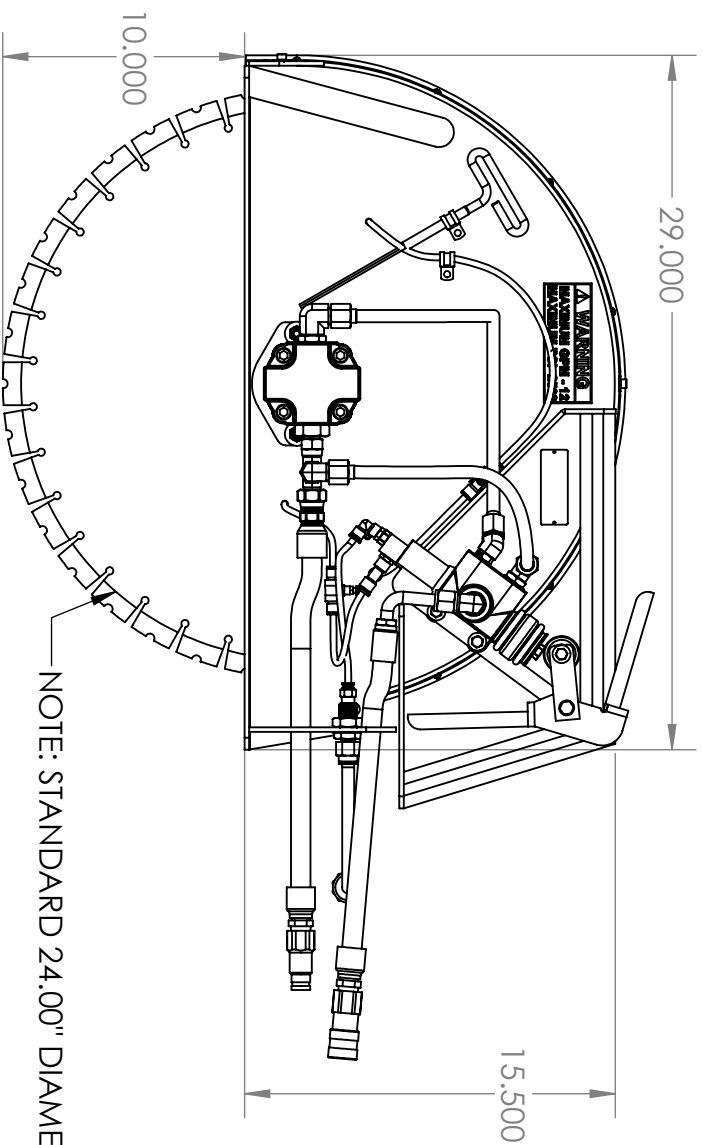

<b>HYDRAULIC RECOMMENDATION</b>	2500psi - 15 gpm
<b>BLADE RPM</b>	2150 rpm @ 15 gpm
<b>HYDRAULIC CONNECTIONS</b>	Parker No Spill 1/2"
<b>MAXIMUM CUTTING DEPTH</b>	10.00"
<b>SAW WEIGHT</b>	46lbs, No Blade
<b>BLADE FLANGE</b>	Flush Cut, 6 on 3.50" 5/16-18 x 82° CS

# **2502545 - Blade Flange**

## **Flush Cut Hydraulic Hand Saws**

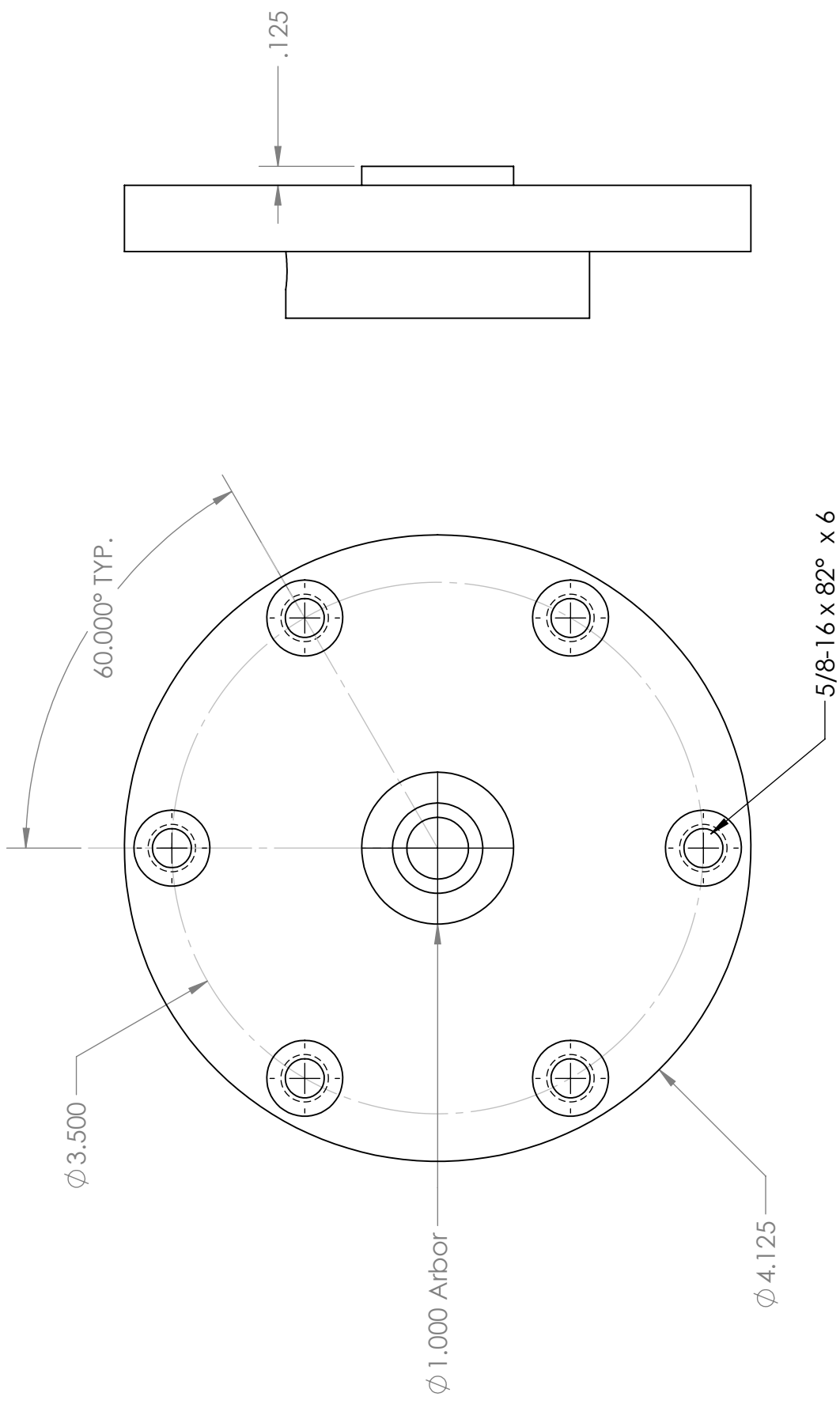

## HAND SAW SAFETY WARNINGS



# CAUTION

### PERSONAL SAFETY

- Read and completely understand instructions before operating saw.
- DO NOT operate saw under the influence of drugs or alcohol.
- Always wear safety approved hearing, eye, head and respiratory protection.
- Sturdy boots with non-slip soles aid in providing proper footing. Use of steel-toed safety boots is recommended.
- Under certain conditions sparks may fly, therefore never wear clothes made of flammable material or operate near flammable items.
- Know how to stop the saw quickly in case of emergency.
- Keep all parts of your body away from the blade at all times, blades are sharp and can cause serious injury or death.
- Do not use hands to search for hydraulic leaks, fluid escaping under pressure can penetrate skin and cause severe injury. If any fluid is injected into the skin, seek medical attention immediately.
- Wear heavy work gloves to avoid contact with concrete slurry, which can cause serious skin irritation.



### BLADE SAFETY

- Examine cutting blades before each use. Blades should have no cracks, nicks, or flaws. Center hole should be undamaged as well. Use only blades recommended for your model.
- This saw should cut only material that is specified on each cutting blade. Read instructions which are located on the blade to determine which material the blade is designed to cut.
- Use only steel centered diamond blades manufactured for use on concrete cutting hand saws DO NOT use high speed steel blades, carbide tipped blades, or abrasive blades.
- Inspect blade flanges for damage, excessive wear, and cleanliness before mounting blade. Blades should fit snugly on clean, undamaged shaft.
- Use only blades marked with a maximum operating speed greater than the blade shaft speed.
- DO NOT remove flow control from hydraulic circuit. Do NOT exceed the maximum safely allowable speed. DO NOT operate this equipment if you suspect it of exceeding this speed.

### GENERAL SAW SAFETY

- Always relieve all pressure before disconnecting hydraulic hoses. DO NOT apply pressure to damaged hoses or fittings.
- Always remember to keep both hands on the handles when the saw is running.
- Never leave the saw unattended with the hydraulic hoses connected to power unit.

### CUTTING/WORK AREA SAFETY

- Never operate the saw in any application or job where you are not trained or supervised.
- Operate only in well ventilated areas.
- Keep bystanders and or animals out of work area.
- DO NOT operate the saw in areas of combustible materials or fumes. Sparks may occur from blade that could cause a fire or explosion.
- Know the material and work area you are sawing. Hazardous conditions such as live electric, water, or gas lines can be concealed in material.

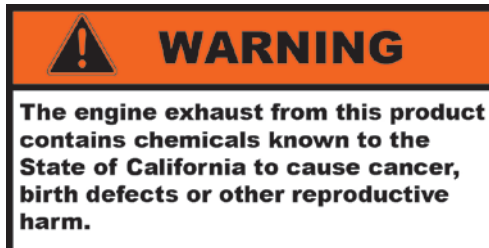

# WARNING

**FAILURE TO COMPLY WITH THE PRECEDING WARNINGS COULD RESULT IN SERIOUS BODILY INJUST OR DEATH!**

## HAND SAW OPERATING PROCEDURES

### **Blade Mounting**

- Be certain that you have correct diamond blade for the application. Contact your authorized servicing dealer for the correct specification. Ensuring that the correct blade is used will greatly increase performance and durability of blades resulting in cost savings.
- The blade shaft flanges and arbor must be inspected for damage and cleaned before mounting the blade. If damaged, replace worn or broken parts. Inspect blade for damage to arbor hole and flange area before attempting to mount blade.
- Make sure the arrow on the blade is pointing in the proper direction of rotation. The drive pin in the outer blade flange must go completely through the blade into the matching hole in the inner blade flange. Using the wrench provided, tighten flanged nut securely (Approximately 30 ft. lbs.). Note that the flanged nut has left hand threads, which tighten by turning counter clockwise.

### **BEFORE SAWING**

- Do not use conventional (wet) diamond blades without water. You must have 2.5-5 gallons of water per minute flowing over the blade for proper cooling and ensuring proper blade life. For wet sawing, be sure to spray holes in the water manifold are open and each side of the blade receives adequate water flow.
- Test your water supply for pressure and flow rate before starting saw.
- Mark the cutting line clearly so that the saw operator can follow the line without difficulty.

### **CUTTING THE LINE**

- With the saw blade above the cut, squeeze the trigger to start the water flowing and allow the saw blade to reach the desired speed before the blade contact the surface. Pivot the saw on the front roller and slowly lower the blade into the cut line. Do not exceed more than 2.00" cutting depth per pass. At the end of the cut, pivot the saw on the front roller and raise the blade until it clears the cut, then release the trigger. Allow the blade to come to a stop before setting down. Increase the depth of cut by 2.00" by increasing the blade diameter and follow the previous cut line. This procedure is known as step cutting. Continue with this procedure in 2.00" increments until you have reached your desired depth of cut.
- When cutting vertical wall cuts, start from the top working down. Make the first pass shallow, being extra careful not to go off the cut line. Increase cut depth with each pass following the previous cut. If the first cut starts to wander, stop sawing and correct the cut by plunging a straight and deeper cut before and after the error. After this go back with the blade cutting twice the depth of the error and cut between the two using the blade to guide past the error.
- Horizontal cuts are the most difficult to make correctly. Before starting the horizontal cut, make sure there is enough room for you to work without reaching beyond your area of control. When sawing from a lift or scaffolding, always figure the amount of hoses you will need to tie off. Leave only what you need for the job.

## HAND SAW MAINTENANCE INSTRUCTIONS

- Check all hydraulic hoses and connections daily. Any leakage of hydraulic fluid will require immediate retightening or replacement of parts. When replacing hydraulic components use only parts with proper pressure ratings. **WARNING!** Before disconnecting hoses, be sure to relieve all pressure. Do not use damaged or non-rated hoses or fittings.
- Tighten fasteners occasionally. Nuts and bolts may become loose particularly after the first few hours of use.
- Check hydraulic supply for correct pressure and flow rate that is appropriate for your saw, all saw have a GPM rating decals.
- Clean saw by removing all accumulated dust or slurry after use. If allowed to dry, the slurry will harden and could impair efficiency and performance.
- Inspect the blade guard frequently for damage and wear. Concrete slurry can erode the aluminum in the blade guard. If any portions of the blade guard measures less than 3/16" (.187) discard unit.

**Pro Series Flush Cut Hydraulic Hand Saw**  
**5800857 - 25.00" 1.61in<sup>3</sup> (15GPM Rated)**

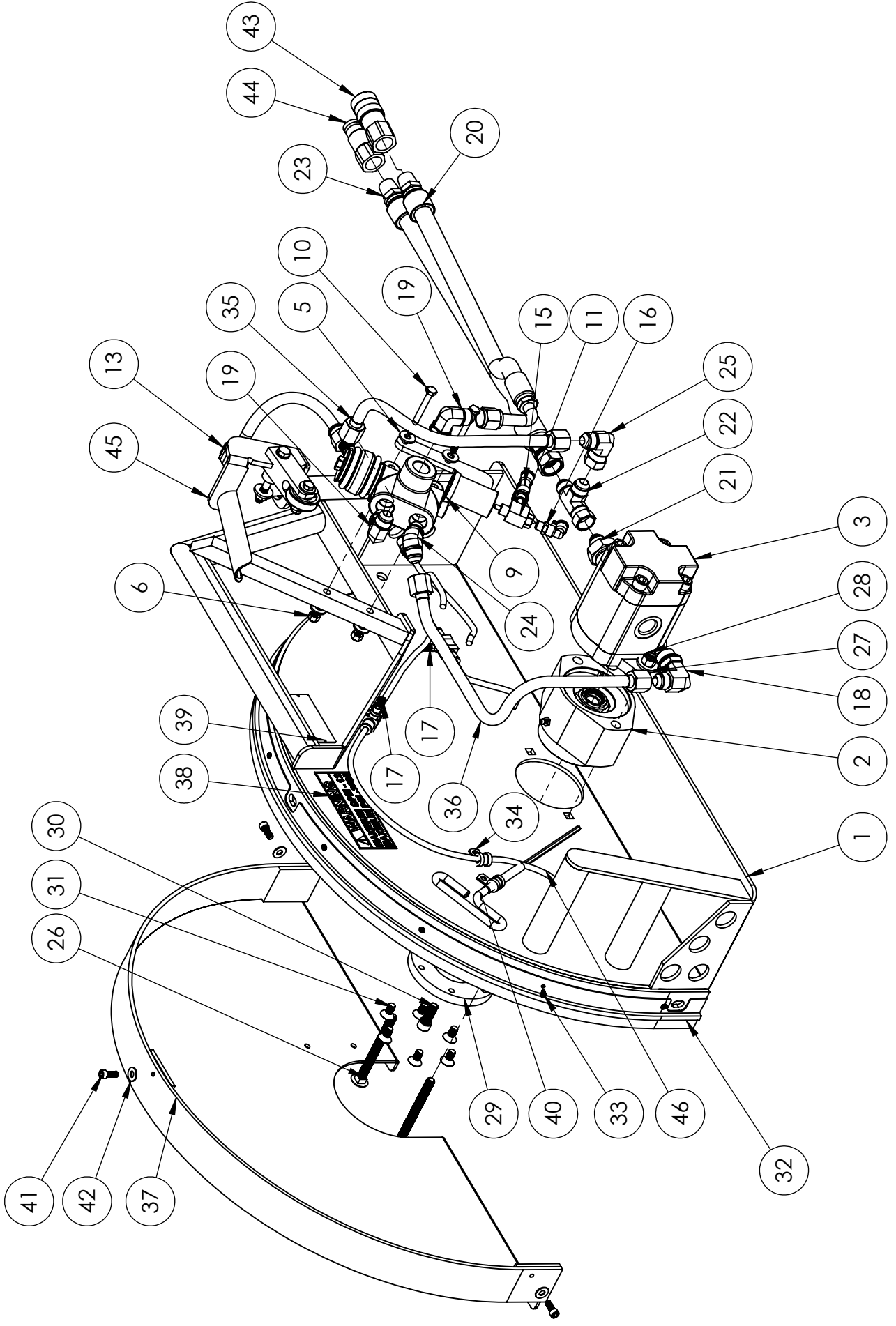



# Pro Series Flush Cut Hydraulic Hand Saw

**5800857 - 25.00" 1.61in<sup>3</sup> (15GPM Rated)**

ITEM NO.	PART NUMBER	DESCRIPTION	QTY.
1	6075087	25.00" Flush Cut Hand Saw	1
2	6040437	Bearing Block, Flush Cut	1
3	2600457	Hydraulic Motor, 1.61 C.I./15GPM w/Anti-Cav	1
4	2503336	Key, 5/32" Sq. x 5/8"	1
5	2900126	1/4" USS Flat Washer	4
6	2900010	1/4-20 Nylon-Insert Hex Locknut	2
7	6070252	HS Metro Valve Assembly	1
8	6075084	Hand Saw Valve Cap	1
9	2505906	U-Cup Seal, 1.00 ID x 1.50 OD	1
10	2901001	1/4-20 x 2.50" Hex Head Cap Screw	2
11	2506345	3 Way Poppet Valve	1
12	3205539	1/4" NPT Bulkhead Coupler	1
13	3201875	Hose Assy, 3/8" x 12, 3/4" F.Garden x 1/4"MPT	1
14	2506349	Push Lock Fitting, 1/4 NPT x 1/4 OD	1
15	2506346	Push Lock Fitting, Run Tee 1/8 NPT x 1/4 OD	1
16	2506348	Push Quick Fitting, Male Elbow 1/8NPT x .250 OD	1
17	2506347	Push Quick Fitting, 1/4 OD Flow Control	2
18	3200803	Elbow Fitting, 1/2" MJIC x 5/8" MORB	1
19	2502924	Elbow Fitting, 1/2" MORB x 1/2" MJIC 90 Deg.	2
20	6075097	Hand Saw Pressure Whip Hose, 24.00"	1
21	2502920	Adaptor, #12 O-Ring x 1/2 MJIC	1
22	3200332	Swivel Run Tee, 08-MJIC x 08-MJIC x 08-FJIC	1
23	6075098	HS Return Hose, 24"	1
24	3200367	08-ORING x 08-MJIC 45°	1
25	3200802	Elbow Fitting, 1/2"MJIC x 1/2" FJIC 90 Deg.	1
26	2903040	3/8-16 x 4.00 Carriage Bolt	2
27	2903018	3/8" Flat Washer	2
28	2900018	Lock Nut, 3/8-16 Nylon	2
29	2502545	Flush Cut Hub	1
30	2900175	3/8-16 x 1.00" SHCS	1
31	2903013	5/16-18 Flat Socket Head Cap Screw	6
32	6075094	25.00" Hand Saw Sweep	1
33	2907006	6-32 x .250" PHPMS-SS	8
34	2502914	1/4" Cable/Hose Loop Clamp	2
35	6070490	Hydraulic Tube, HSFC 25" Rear	1
36	6070480	Hydraulic Tube, HSFC 25" Front	1
37	6075090	25.00" Flush Cut Hand Saw Cover	1
38	1800767	Warning Label, 15GPM 2500 PSI	1
39	1800169	Serial Number Plate, US	1
40	2900750	T-HANDLE HEX KEY 3/16	1
41	2907005	1/4-20 x 5/8 SHCS	3
42	2900009	1/4 SAE Flat Washer	3
43	3200104	Coupler, 1/2" Q.D.	1
44	3200105	Nipple, 1/2" Q.D.	1
45	2505905	Dual Trigger Assembly, Hydraulic Hand Saws	1
46	1104098	1/4" OD Flexible Tubing (Sold Per Inch)	54

# Bearing Block Assembly

## 6040437 - Assembled Flush Cut Bearing Block

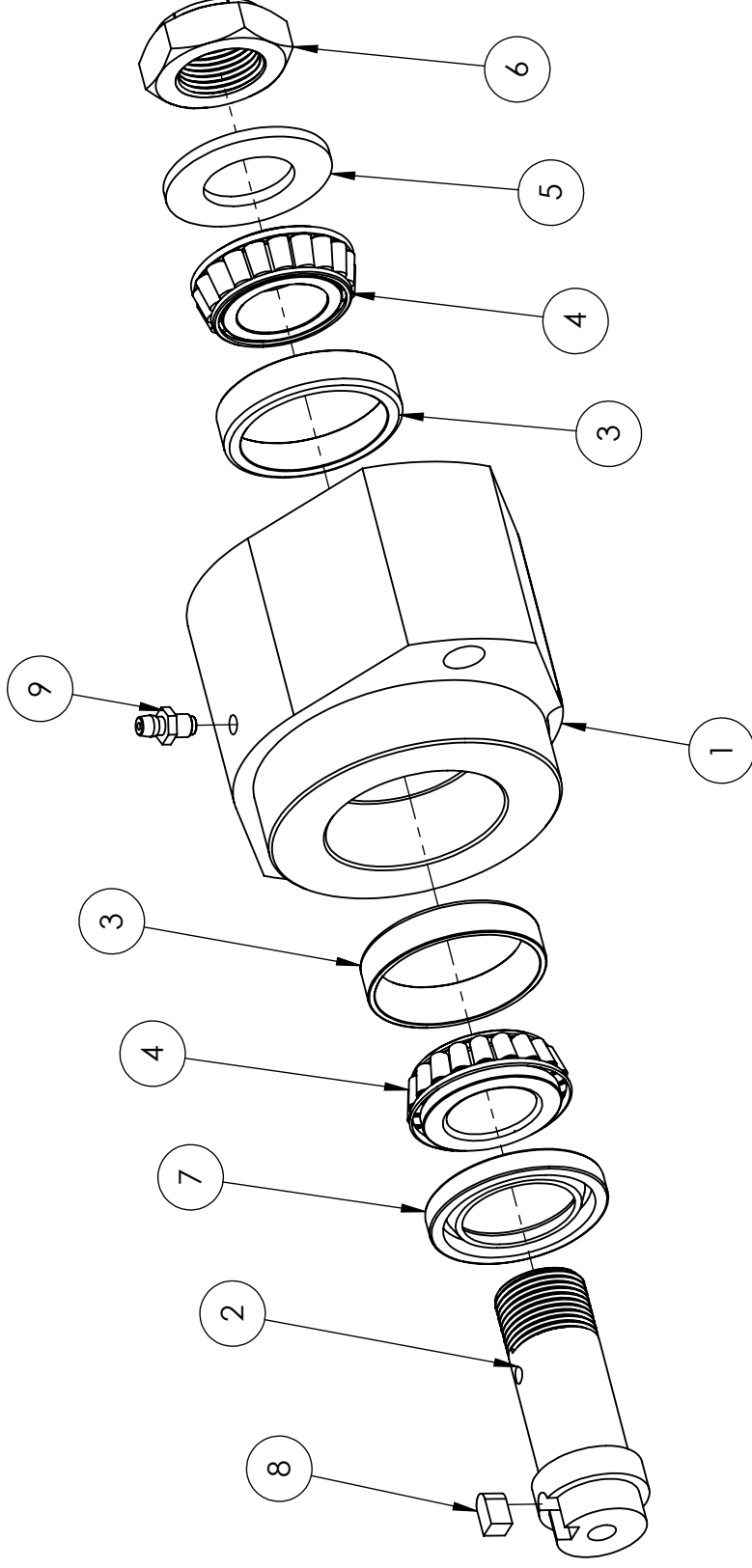

NOTE: WHEN REPAIRING/REBUILDING BEARING BLOCK, LOCK NUT (2902961) MUST BE TORQUED TO 50LB.-FT. ROTATE SHAFT BY HAND TO ENSURE NO END PLAY IN SHAFT, SHAFT SHOULD NOT BE OVERTIGHTENED.

WHEN REPAIRING/REBUILDING BEARING BLOCK, GREASE ADEQUATELY USING NLGI No.2 GREASE. BEARING BLOCK GREASE CAPACITY IS 1.5oz.

ITEM NO.	PART NUMBER	Description	QTY.
1	2505077	Aluminum Housing, FC HS	1
2	2702945	Flush Cut Shaft	1
3	2501629	Bearing Race L44610	2
4	2501628	Bearing L44643	2
5	2502934	Spindle Washer 1"	1
6	2902961	Expanding Hex Locknut RH	1
7	2501494	Seal, 1-1/4" x 1.979" x 1/4"	1
8	6075059	Key, 1/4" Sq X 15/32"	1
9	2900706	Grease Zerker, 1/4-28 Straight	1

# Metro Valve Assembly

## 6070252 - Valve Assembly

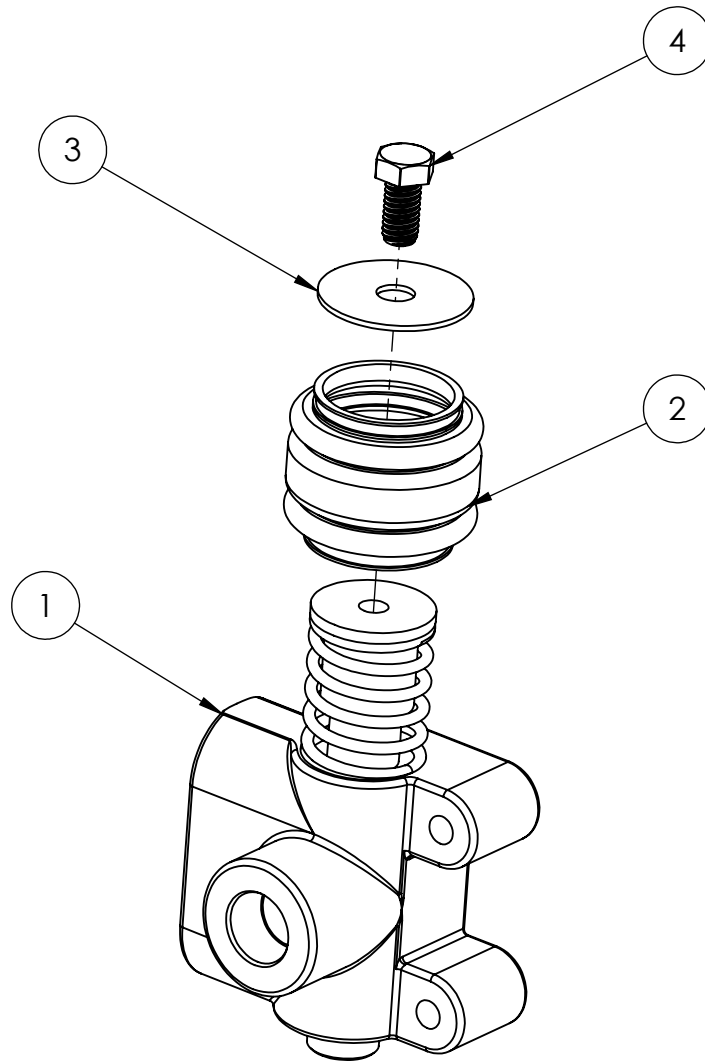

ITEM NO.	PART NUMBER	DESCRIPTION	QTY.
1	2702688	Metro Flow Valve	1
2	2507033	Bellow, Hand Saw	1
3	2907070	Washer, 3/8" x 1-5/8"	1
4	2900196	3/8-16x.750 HEX CAP SCREW	1

# Dual Trigger Assembly

2505905 - For Use on Hydraulic Hand Saws

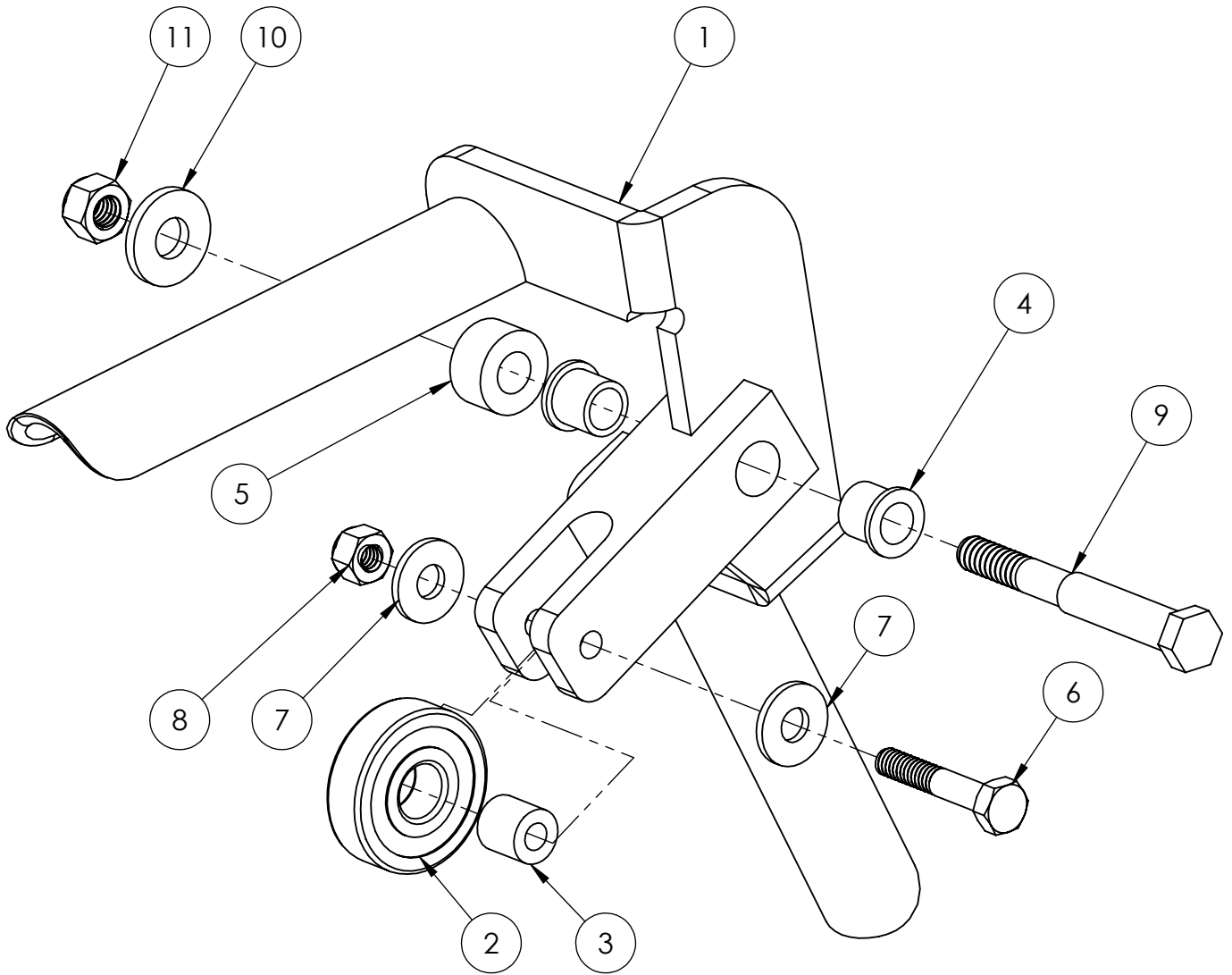

ITEM NO.	PART NUMBER	DESCRIPTION	QTY.
1	6075083	HS Dual Trigger Weldment	1
2	2502897	Bearing	1
3	2502576	1/4" x 1/2" Sleeve Bushing	1
4	2501583	Bearing, 3/8" ID Flanged Bronze	2
5	2501515	Bushing UHMW	1
6	2900048	1/4-20 x 1.50" HHCS (Grade 5)	1
7	2900126	1/4" USS Flat Washer	2
8	2900010	1/4-20 Nylon-Insert Hex Locknut	1
9	2506344	Hand Saw Pivot Bolt	1
10	2900567	5/16" Flat Washer	1
11	2900039	5/16"-18 Nylock Hex Nut	1

# Casappa Hydraulic Motor 2600457 - 1.61 C.I. w/Anti-Cav

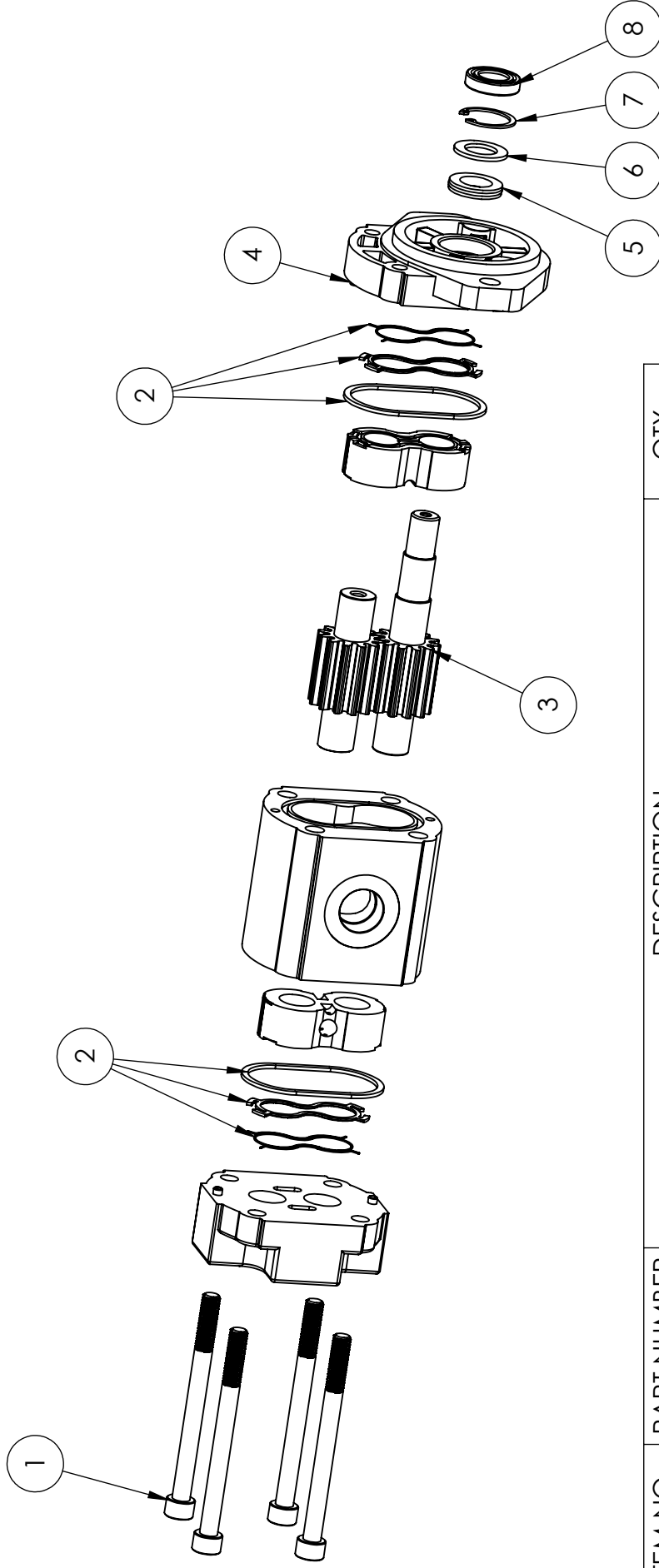

ITEM NO.	PART NUMBER	DESCRIPTION	QTY.
1	2901970	M10-1.50 x 120mm SHCS	4
3	2708011	5/8" Shaft, 1.61 CI Hydraulic Motor W/1/4-20 Tapped End	1
4	3205792	Casappa Motor Front Cover	1
5	2501630	Hydraulic Motor Seal	1
6	2502563	Backing Ring	1
7	2707005	Seal Snap Ring	1
8	2507139	Wiper Seal	1
14	2502933	Hydraulic Motor Seal Kit, Bi-Rotational PLM 20.03-20.31	1





## **EQUIPMENT AND PARTS WARRANTY**

Diamond Products warrants all equipment manufactured by it against defects in workmanship or materials for a period of one (1) year from the date of shipment to Customer.

The responsibility of Diamond Products under this Warranty is limited to replacement or repair of defective parts at Diamond Products' Elyria, Ohio factory, or at a point designated by it, of such parts as shall appear to us upon inspection at such parts, to have been defective in material or workmanship, with expense for transportation and labor borne by Customer.

In no event shall Diamond Products be liable for consequential or incidental damages arising out of the failure of any Product to operate properly.

Integral units such as engines, electric motors, batteries, transmissions, etc., are excluded from this Warranty and are subject to the prime manufacturer's warranty.

**THIS WARRANTY IS IN LIEU OF ALL OTHER WARRANTIES, EXPRESSED OR IMPLIED, AND ALL SUCH OTHER WARRANTIES ARE HEREBY DISCLAIMED.**



333 Prospect Street, Elyria, Ohio 44035  
(440) 323-4616 • (800) 321-5336 • Fax (440) 323-8689  
[www.diamondproducts.com](http://www.diamondproducts.com)