

CORE DRILL OPERATIONS MANUAL



MODEL :

CB700



SAFETY



To maintain the operation safety,
make sure to read and understand
this instruction book **BEFORE**
operating this equipment.



SAFETY



- 1. When operating the drill, be sure to wear proper safety gear, such as safety glasses, dust mask, glove, and hearing protection. A hard hat is also recommended.**
- 2. Never operate unless proper footing and balance is possible at all time.**
- 3. Wear proper apparel. Do not wear loose clothing or accessories. Keep hair and body parts away from openings and moving parts.**
- 4. Wet coring bits MUST be used with water. Flow should be kept at sufficient rate and volume.**
- 5. Use ONLY diamond impregnated core bits with this drill.**
- 6. Do not force the machine. Use the drill properly and as intended.**
- 7. Anchor bolts should always be used to secure the base on a cracked, uneven or vertical surfaces.**
- 8. Maintain alertness while operating the machine. Failure to maintain attention, by the operator, may lead to serious injury.**
- 9. Do no operate the machine when you are tired or while under the influence of drugs, alcohol or any medication.**
- 10. Use common sense when operating any power tool.**

11. **Keep work area clean and well lit.**
12. **Never operate this unit when flammable materials or vapors are present. Electrical devices produces sparks or arcs which can cause a fire or explosion.**
13. **Do not expose the drill to rain or wet conditions to minimize electric shock.**
14. **Do not obstruct motor air intake or outtake to maximize performance.**
15. **Before beginning work, familiarize self with the work site and its surrounding. Take notice of circumstances which may impede work or traffic, observe soil conditions (good bearing or not) and take measures to ensure safety (e.g. the shielding of road works from public traffic).**
16. **Take measures to ensure that the drill is in a safe and trouble-free condition to operate. Use the drill only when all protective devices (i.e. guards, noise absorbers, emergency-off devices) are in place and in working order.**
17. **A visual check of the machine must be made at least once a shift to ensure that early signs of problems are noticed. Any such indication (including changes in machine performance or behavior) must be reported to the appropriate supervisor.**
18. **In the case of a malfunction, stop the drill immediately, unplug and secure it. Fix the problem as soon as possible.**
19. **To stop and start the drill follow the operating instructions and observe any indicator lights.**
20. **Keep the drill out of reach of children.**

21. Make sure power is in “OFF” position before plugging in power cord to prevent any accidental activation.

22. If cord/plug is damaged do not operate.

23. Plug should be of proper type to mate to outlet. Never modify the plug in any way. Adapter plugs should not be used either for grounded power tools. Power received must be as specified on the drill nameplate.

24. Be sure to connect the plug to a properly grounded receptacle to reduce the risk of electric shock.

25. To reduce the risk of electrical shock, we recommend the use of GFCI and to refer servicing to a qualified professional. Avoid body contact with earthed or grounded surfaces such as metal objects.

26. Before operating, be sure the activated drill will be of no danger to anyone. Check to make sure all adjusting key or wrench were removed.

27. When machine is plugged in do not leave it unattended. Unplug prior to servicing, when changing accessories, and when not in use.

28. Never carry machine by cord. Do not pull cord to unplug. Keep cord away from heat, sharp edges and oil.

29. When using an extension cord, make sure it is in good condition and heavy enough to carry the current drawn by the machine. Refer to the extension cord table in the “Electrical Specifications” section for the correct gauge depending on the desired cord length and the machine’s horsepower and voltage.

30. Service on the drill should only be performed by a qualified technician.

HEALTH WARNING

1. Some dust created by power sanding, sawing, grinding, drilling, and other construction activities contain chemicals known to cause cancer, birth defects or other reproductive harm. Some examples of these chemicals are:

- A. Lead from lead-based paints**
- B. Crystalline silica from bricks, cement and other masonry products**
- C. Arsenic and chromium from chemically-treated lumber**

2. Your risk from these exposures varies, depending on how often you do this type of work. To reduce your exposure to these chemicals: Work in a well ventilated area, and work with approved safety equipment, such as those dust masks that are specially designed to filter out microscopic particles.

UNPACKING

1. Open the carton containing the drill motor. Remove the drill and place it on a flat, level working area. Be sure that the followings items are removed before discarding the carton:

A. Size 36 Open box wrench

B. Size 48 Open box wrench

SETUP

NOTE: The drill motor should not be plugged in and the spindle should be static when following any of the following procedures!

1. Mounting the Drill Motor

A. Attached to the drill body is a universal mounting block. Study the block and drill stand carriage mounting holes. If it is determined the block is not required, remove it so that the drill may mount properly to the carriage.

B. First install the appropriate key size into the available key way. Next line up the mounting holes from the drill motor to the holes on the carriage. The screws must pass through the carriage first then into the motor body.

C. Once the screws are tightened, look at the assembly from the side. Both the drill motor and carriage mounting face must sit flush against each other.

D. The carriage must be properly adjusted to the drill stand column. Check that the drill motor is secure by shaking the motor using moderate force. No movement should be possible. If movement is felt independent from the column, the carriage needs to be adjusted. See the drill stand manual for proper adjustment instructions.

2. Installing a Core Bit

A. Raise the mounted drill motor to the proper height. The core bit should be able to sit directly underneath the spindle.

B. Apply grease to the spindle thread to prevent corrosion and easier core bit removal.

C. If a copper washer or slip collar is available, slide it onto the spindle.

D. Lastly position the core bit directly underneath the spindle and screw it on.

3. Setting the Proper Spindle Speed

A. Located on the side of the drill motor is a circular speed select knob. Loosen the knob by rotating it counter-clockwise.

B. Slide the knob to the left for low speed (600RPM) or to the right for high speed (1200RPM) coring.

C. After selecting the required speed, lock the knob by rotating it clockwise.

4. Attaching a Hose to the Water System

A. Pre-attached to the swivel collar is a male quick-disconnect water fitting with a built water control valve. The swivel assemble allows a hose to attach to the drill motor from any angle rotated about the spindle axis. Water will be fed through the spindle and down the core bit.

B. Attach a water hose with the proper female quick-disconnect fitting to the drill motor's water inlet.

C. Allow water to flow through the system to make sure flow is continuous and the rate is sufficient. Shut-off the flow by turning the valve on the swivel collar.

FEATURES

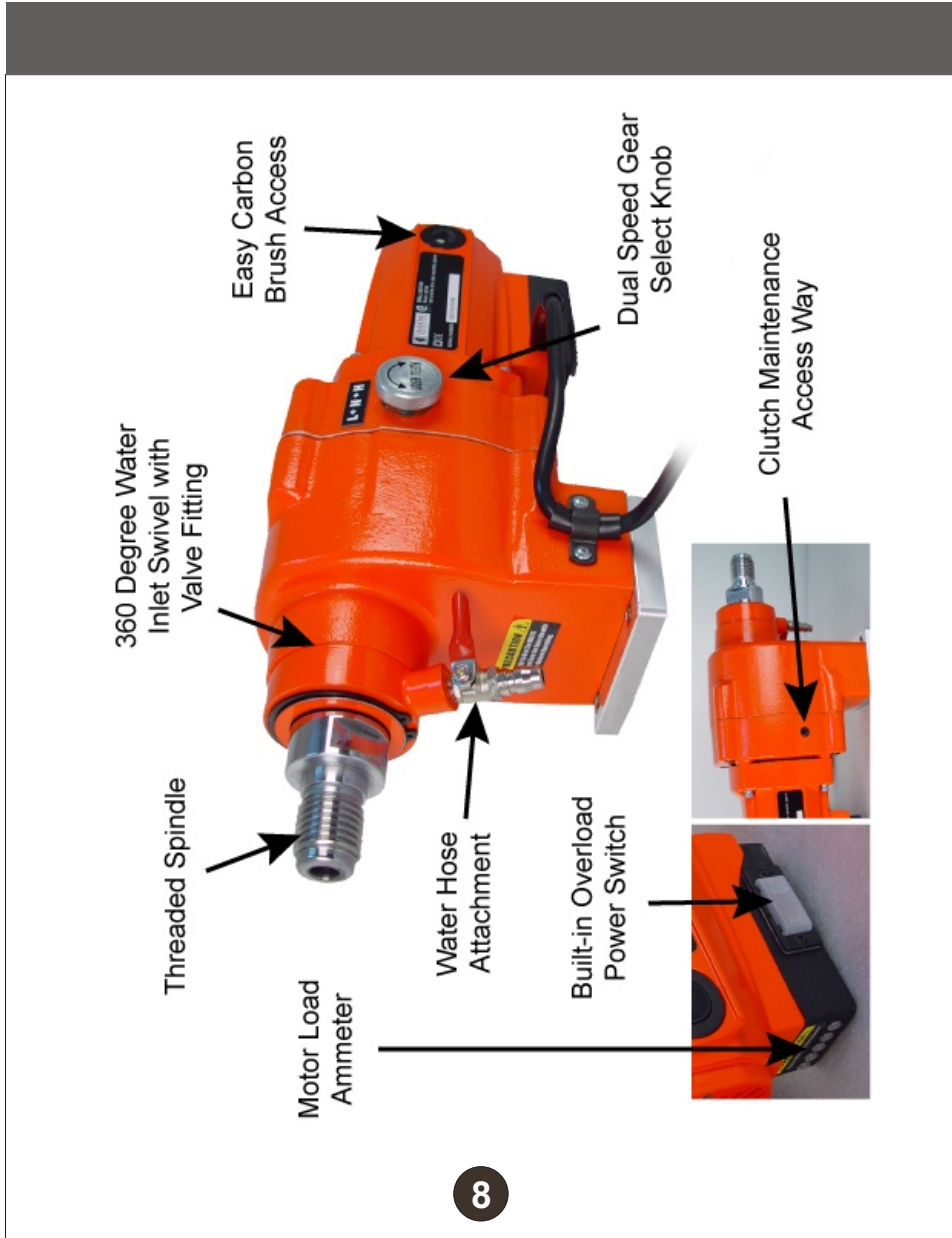

SPECIFICATIONS

Model Spec	<i>CB700</i>
VOLTAGE	115V (60Hz)
POWER	3HP (2.2kW), 20A
SPEED	600 ~ 1200 RPM
PHASE	1
APPLICABLE BIT DIAMETER	1" (25MM) ~ 8" (203MM)
WEIGHT	48 LBS (21.8 KG)

OPERATION

1. Coring Operation

- A. Place water collecting ring in place as necessary.
- B. Make sure the drill stand is properly secured to the work surface. If not follow the instructions provided in the drill stand manual.
- C. Check that the spindle speed is at the correct setting. If not adjust as instructed in the “setup” section.

NOTE: The motor must be OFF and the spindle must not be in motion when changing the speed setting. Failure to follow these conditions can result in gear or motor damage.

- D. Turn the water valve on the drill motor on. There must be sufficient flow of water to the core bit.
- E. Activate the drill and allow the spindle to achieve peak RPM before letting the bit engage the work surface.
- F. During the initial portion of the coring process, the bit may wander. Apply a light amount of force at first until the bit appears to have cored out a groove.
- G. While coring do not apply too much downward force. Refer to the motor load ammeter as reference. To achieve constant even and sufficient force, keep the yellow LED lit. Do not allow the red LED to become lit.

WARNING: Warning do not core upwards!

H. When the coring process is complete, the material removed or inner core may become lodged inside the bit. Leave the drill running and raise the drill from the work surface.

I. Turn off the drill and turn the water valve on the drill motor off.

MAINTENANCE

WARNING: For your safety, before performing any maintenance on the drill turn **OFF** the power switch and **UNPLUG** the power cord.

1. General Rules

- A. Always clean the machine before performing any maintenance/repair.**
- B. A clean machine makes visual inspection for problems easier to notice.**

2. Steps to Follow When Cleaning

A. Please do not use aggressive cleaners (i.e. containing solvents). Do not use high-pressure water jets, aggressive detergents or solutions and liquids with a temperature exceeding 86°F! Use a fluff-free cloth only.

B. For the sake of safety, no water/cleaning liquid/vapor may penetrate into the electric motor, connectors/plugs, switches, etc. Cover all apertures, holes in the housing, connectors or plugs, etc. or seal them with adhesive tape!

C. Use a cloth which may be lightly moistened only for removing dust and dirt. Hard packed dirt can be removed with a soft brush.

D. After cleaning, remove all covers and adhesive tape! All screws/nuts which you may have loosened must be tightened again! After wet cleaning, try the machine on a power outlet which is equipped with a power breaker (i.e. fault current circuit breaker). If the fault current circuit breaker cuts the power supply, the machine must be inspected by an authorized dealer prior to use!

3. Carbon Brush Replacement

- A. Unplug the drill motor before proceeding any further.**
- B. Locate the carbon brush caps found near the air inlet of the motor housing. They are on opposing sides. Remove the caps using a flat screw driver. The brushes contact leads should pop out as soon as the caps are off; if not, use the screw driver to nudge them out.**
- C. When installing the new brushes, make sure they fit snugly into the slots. Do not modify the replacement brushes (i.e. file them down) or use non OEM brushes, as it may damage the armature and in doing so voids the manufacturer warranty.**
- D. Perform steps one through three in reverse to reinstall the caps. Note do not over tighten the caps as they may be damaged.**

4. Adjusting the Mechanical Clutch

- A. Unplug the drill motor before proceeding any further.**
- B. If, while coring, the clutch slips when the ammeter only illuminates the green or yellow LED indicator, then the clutch nut needs to be tightened.**
- C. To begin a special tool is needed to engage the clutch. Contact your nearest authorized distributor or service center for parts.**
- D. Locate the four recessed socket head screws holding the gear housing together and remove them.**

E. Gently pull the gear housing apart. Only a small separation is needed to fit two flat screw drivers into the housing's gap. The screw drivers should be inserted in opposing directions. Gently apply an even amount of force on both tools to complete the housing separation.

F. Using the supplied open box wrench, hold the spindle in place.

G. Insert the torque wrench with a compatible clutch tool onto the gear housing clutch nut as shown below. Rotate the wrench clockwise until the gauge reads 20N-m #6063140

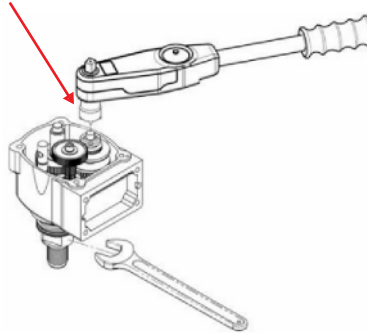

I. With the clutch nut properly tightened, reassemble the housing. To reassemble press the two halves of the housing together. Make sure the orientation and internal components mate correctly. Now sit the drill on the motor's back side so the spindle faces upwards. Using a mallet lightly tap the housing closed. Every so often turn the spindle to guarantee the gears are meshing together instead of interfering. Force must be distributed evenly around the housing to keep the two halves level as they come together.

J. Reattach the four screws to complete the gear housing assembly.



WIRING DIAGRAM

1. Electrical Specifications:

3HP (2.2kW)
115V
20A
600~1200 RPM
60Hz
1 Phase

2. Recommendations

A. It is recommended that a 20 amp circuit be used while operating this drill machine. This will prevent any loss of power or interruption.

B. Always plug the motor as close as possible to the power source while operating. This will allow you to receive optimum electricity.

3. Electrical Wiring Diagram

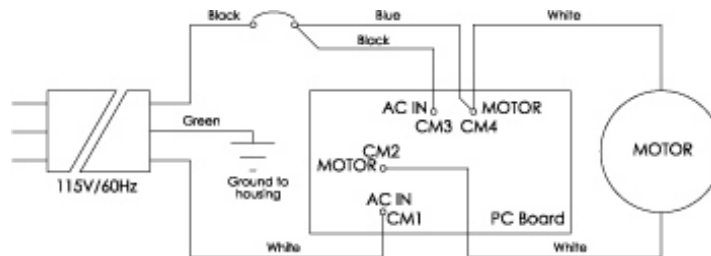

TROUBLESHOOTING

Problem:	Bit is jammed while coring.
Possible Cause:	Debris is lodged between core and bit.
Solution:	Rotate bit in both directions using spanner to release debris then inspect bit.
Possible Cause:	Drill stand is not secured to work surface.
Solution:	Reset base and secure properly using vacuum base or anchor.
Possible Cause:	Diamond rims have worn away.
Solution:	Replace core bit.
Problem:	Coring speed has reduced.
Possible Cause:	Bit has encountered rebar.
Solution:	Adjust feed pressure to avoid motor overload.
Possible Cause:	Diamonds have glazed over.
Solution:	Dress diamond rim on bit and check water feed rate.
Possible Cause:	Diamond rims have worn away.
Solution:	Replace core bit.
Possible Cause:	New core bit.
Solution:	Core at a slow rate during first 2-3 coring cycles.
Problem:	Core bit appears to sway.
Possible Cause:	Shaft was been damaged.
Solution:	Replace shaft and check bearing arrangement.
Possible Cause:	Bit is deformed or damaged.
Solution:	Replace core bit.
Possible Cause:	Chips are attaching to the bit.
Solution:	Inspect core bit and increase water flow rate.

EXPLODED VIEW

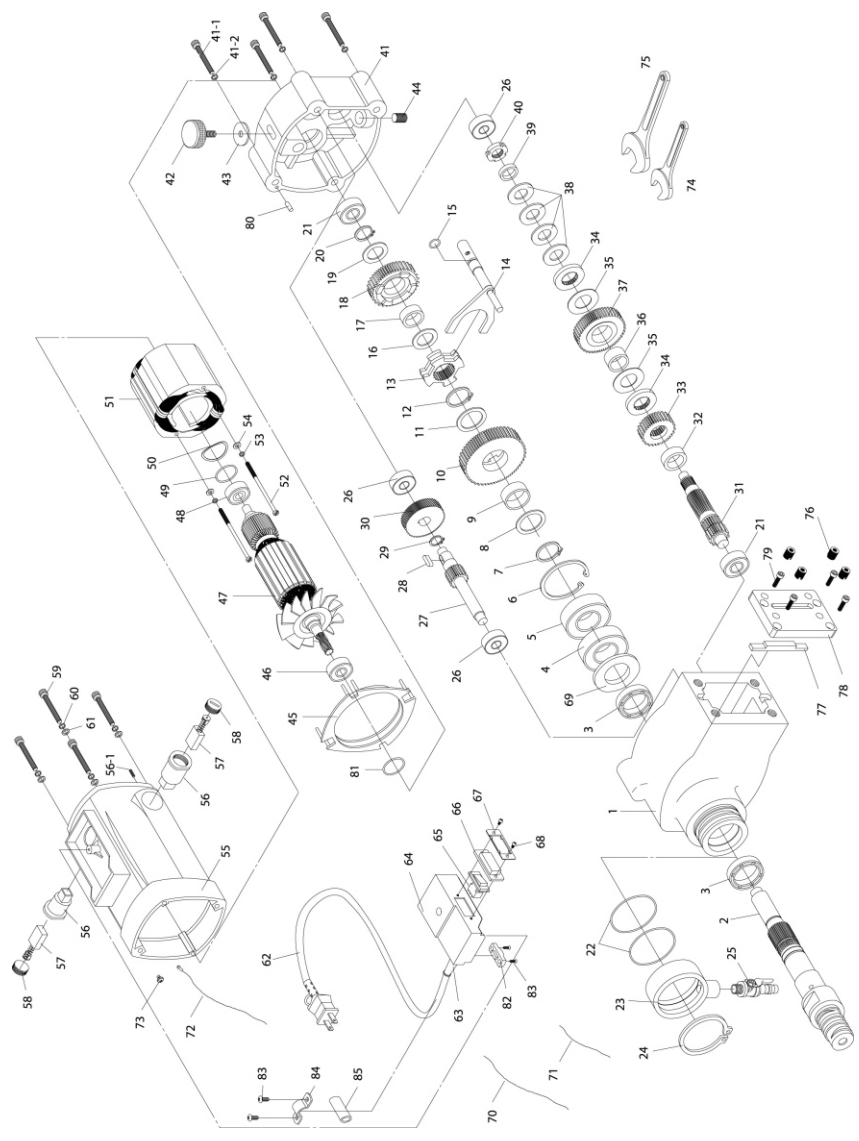

CB700

PARTS LIST

CB700

#	ITEM	QTY	PART NO.
1	Gear case	1	6063050
2	Main shaft	1	6063051
3	Seal 48x34x8	2	6063052
4	Bearing 6206ZZ/C2	1	6063053
5	Bearing 6206LLU	1	6063054
6	Snap ring R62	1	6063055
7	Snap ring S30	1	6063056
8	Metal collar	2	6063057
9	Brass collar 35x29x12	1	6063058
10	First gear	1	6063059
11	Metal collar	1	6063060
12	Snap ring S28	1	6063061
13	Shift ring	1	6063062
14	Shift lever	1	6063063
15	O-ring	1	6063064
16	Metal collar	2	6063065
17	Brass collar 28x22x9	1	6063066
18	Second gear	1	6063067
19	Metal collar	1	6063068
20	Snap ring S22	1	6063069
21	Bearing 6202Z	2	6063070
22	O-ring 60x2.0	2	6063071
23	Water supply cover	1	6063072
24	Snap ring S63	1	6063073
25	Water cock	1	6063074
26	Bearing 6201Z	3	6063075
27	First pinion	1	6063076
28	Woodruff key 5x5x12	1	6063077
29	Snap ring	1	6063078
30	Third gear	1	6063079

PARTS LIST

CB700

#	ITEM	QTY	PART NO.
31	Second pinion	1	6063080
32	Metal collar	1	6063081
33	Forth gear	1	6063082
34	Plate	1	6063083
35	Friction plate	1	6063084
36	Brass collar	1	6063085
37	Fifth gear	1	6063086
38	Disk spring 35.2x18.3x2.0	4	6063087
39	Metal collar 5T	1	6063088
40	Fine U-nut	1	6063089
41	Diaphragm	1	6063090
41-1	Socket head cap screw M8x1.25x60L	4	6063091
41-2	Spring washer M8 ODx13.6 ODx1.8T	4	6063092
42	Speed change knob	1	6063093
43	Rubber washer	1	6063094
44	Plug	1	6063095
45	Baffle	1	6063096
46	Bearing 6201LLU	1	6063097
47	Armature	1	6063098
48	Bearing 6200ZZ	1	6063099
49	Filling ring 6200	1	6063100
50	O-ring	1	6063101
51	Field	1	6063102
52	Round head phillip screw - cone point M5x85	2	6063103
53	Spring washer 5MM	2	6063104
54	Flat washer 5MM	2	6063105
55	Motor house	1	6063106

PARTS LIST

CB700

#	ITEM	QTY	PART NO.
56	Brush tube	2	6063107
56-1	Brush tube screw M5x10	2	6063108
57	Carbon brushes (2)	2	6063109
58	Brush cover	2	6063110
59	Socket head cap screw M6x1.0x45	4	6063111
60	Spring washer M6 ODx10.5 ODx1.5T	4	6063112
61	Washer 1/4x13x1	4	6063113
62	Electric power	1	2704063
63	Cable cover	1	6063115
64	Switch box with LED indicator	1	6063116
65	Switch	1	2704059
66	Switch cover	1	2704060
67	Switch plate	1	2704061
68	Flat head phillip screw - cone point M3x4 (1/8x1/4)	2	2704062
69	Seal 47.5x36x2	1	6063121
70	Cable 24cm	1	6063122
71	Cable 8cm	1	6063123
72	Earth cable	1	6063124
73	Round head phillip screw - flat point M4x0.7x6L	1 1	6063125
74	Spanner 36	1	2704103
75	Spanner 48	1	2704104
76	Cooper screw 1/4 pipe thread	4	6063126
77	T-shape key 10x10x105	1	6063127
78	Spacer block 15mm	1	6063128
79	Socket head cap screw M8x20	4	6063129

Please call us if for any reason you are having difficulty that cannot be resolved with the troubleshooting guide included in this manual. We would like to help.

Give us a call at
1-800-321-5336
or e-mail us at
dp@diamondproducts.com

To better service our customers as expediently as possible, please make sure that you have the manufacturing serial number at hand before contacting us.



333 Prospect Street • Elyria, OHIO 44035 • USA