

DIAMOND
PRODUCTS

CONCRETE SAW
PARTS LIST

MODEL
CC6500

(Revised 6-1-2001)

⚠ WARNING: Do not exceed blade speed (RPM) shown for each blade size. Excessive blade speed could result in blade breakage and serious personal injury!

CC6565 RPM CHART

BLADE SIZE	BLADE RPM	BLADESHAFT SHEAVE	ENGINE SHEAVE	ENGINE RPM	GOVERNOR HOLE	BELT SIZE	FLANGE SIZE	MAX CUT DEPTH
14"	2,900	4.12"	4.00"	3,000	10	3VX560	4-1/2"	4-5/8"
20"	2,450	4.50"	4.00"	2,750	9	3VX560	4-1/2"	7-5/8"
26"	1,950	4.50"	4.00"	2,200	6	3VX560	4-1/2"	10-5/8"
30"	1,575	5.60"	4.00"	2,200	6	3VX560	6-1/4"	11-3/4"
36"	1,425	5.60"	4.00"	2,000	5	3VX560	6-1/4"	14-3/4"
42" *	1,050	7.60"	3.65"	2,200	6	3VX710	8"	16-3/4"
48" *	960	7.60"	3.65"	2,000	5	3VX710	8"	19-3/4"

CC6560 RPM CHART

BLADE SIZE	BLADE RPM	BLADESHAFT SHEAVE	ENGINE SHEAVE	ENGINE RPM	BELT SIZE	FLANGE SIZE	MAX CUT DEPTH
20"	2,425	4.50"	3.65"	3,000	3VX500	4-1/2"	7-5/8"
26"	2,025	4.50"	3.65"	2,500	3VX500	4-1/2"	10-5/8"
30"	1,650	5.60"	4.00"	2,300	3VX530	6-1/4"	11-3/4"
36"	1,425	5.60"	4.00"	2,000	3VX530	6-1/4"	14-3/4"

CC6530E / CC6540E RPM CHART

BLADE SIZE	BLADE RPM	BLADESHAFT SHEAVE	MOTOR SHEAVE	MOTOR RPM	BELT SIZE	FLANGE SIZE	MAX CUT DEPTH
20"	2,450	4.12"	5.60"	1,800	3VX560	4-1/2"	7-5/8"
26"	2,000	4.50"	5.00"	1,800	3VX560	4-1/2"	10-5/8"
30"	1,700	5.00"	4.75"	1,800	3VX560	6-1/4"	11-3/4"
36"	1,400	5.30"	4.12"	1,800	3VX560	6-1/4"	14-3/4"
42" *	1,075	6.90"	4.12"	1,800	3VX710	8"	16-3/4"
48" *	1,075	6.90"	4.12"	1,800	3VX710	8"	19-3/4"

* For Reference Only (Must have Frame Extension Kit to Convert)

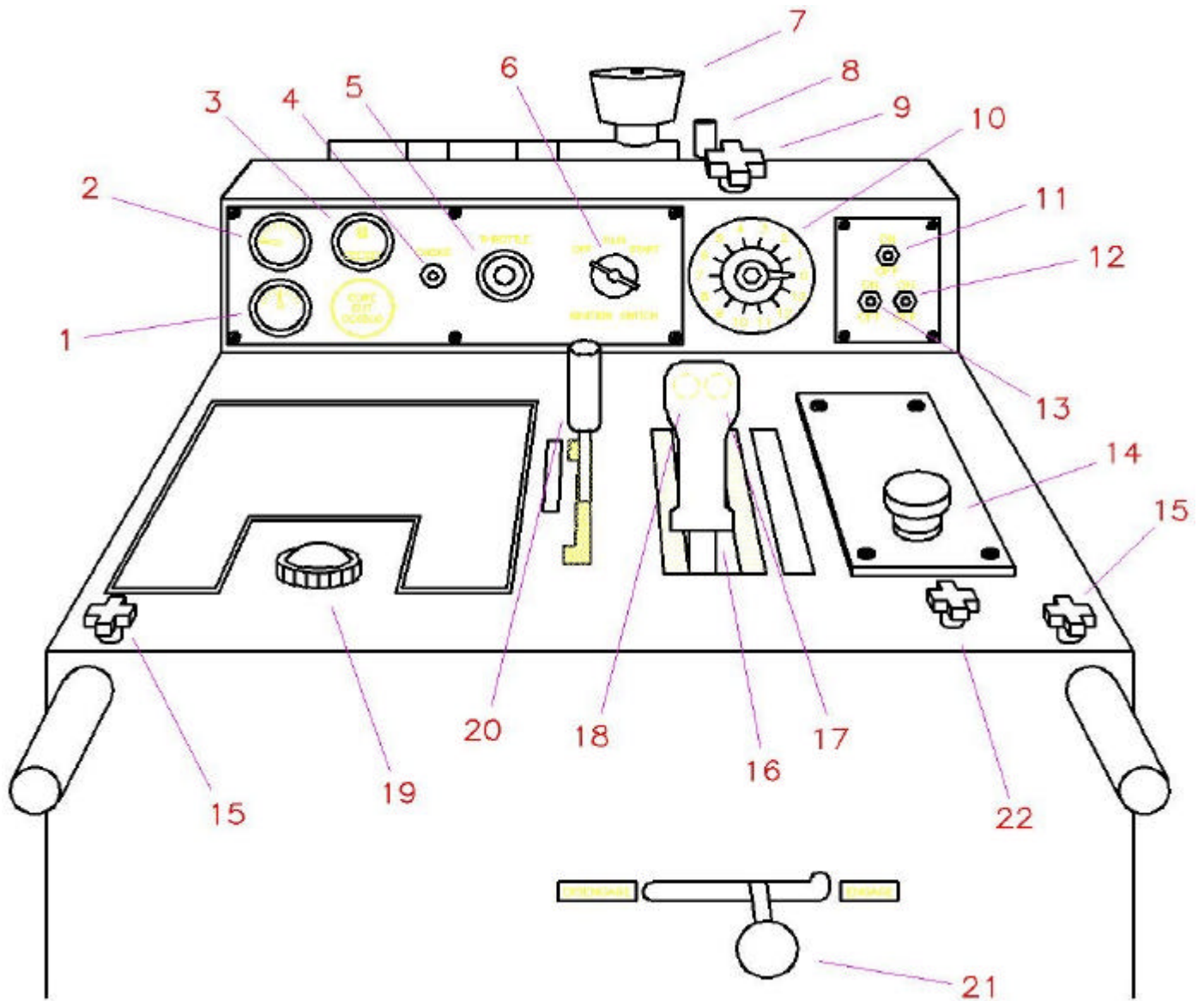

CC6565 Gas Saw Controls Legend

- | | | | |
|----|-----------------------------------|----|--|
| 1 | Volt Meter | 12 | Spotlight Switch (Optional) |
| 2 | Oil Pressure Gauge | 13 | Water Pump Switch (Optional) |
| 3 | Hour Meter | 14 | Emergency Stop Button |
| 4 | Choke Control | 15 | Handle Lock Knobs |
| 5 | Vernier Throttle Control | 16 | Speed Control Lever |
| 6 | Ignition Switch | 17 | Lower Pushbutton |
| 7 | Pre-Cleaner | 18 | Raise Pushbutton |
| 8 | Air Cleaner Restriction Indicator | 19 | Fuel Tank Cap |
| 9 | Depth Stop Knob | 20 | Transmission Engagement Lever * |
| 10 | Cutting Depth Indicator | 21 | Transmission Engagement Lever ** |
| 11 | Water Safety Switch (Optional) | 22 | Lowering Speed Metering Valve (Optional) |
- * For Eaton Transmission Only
 ** Optional for Sundstrand Transmission Only

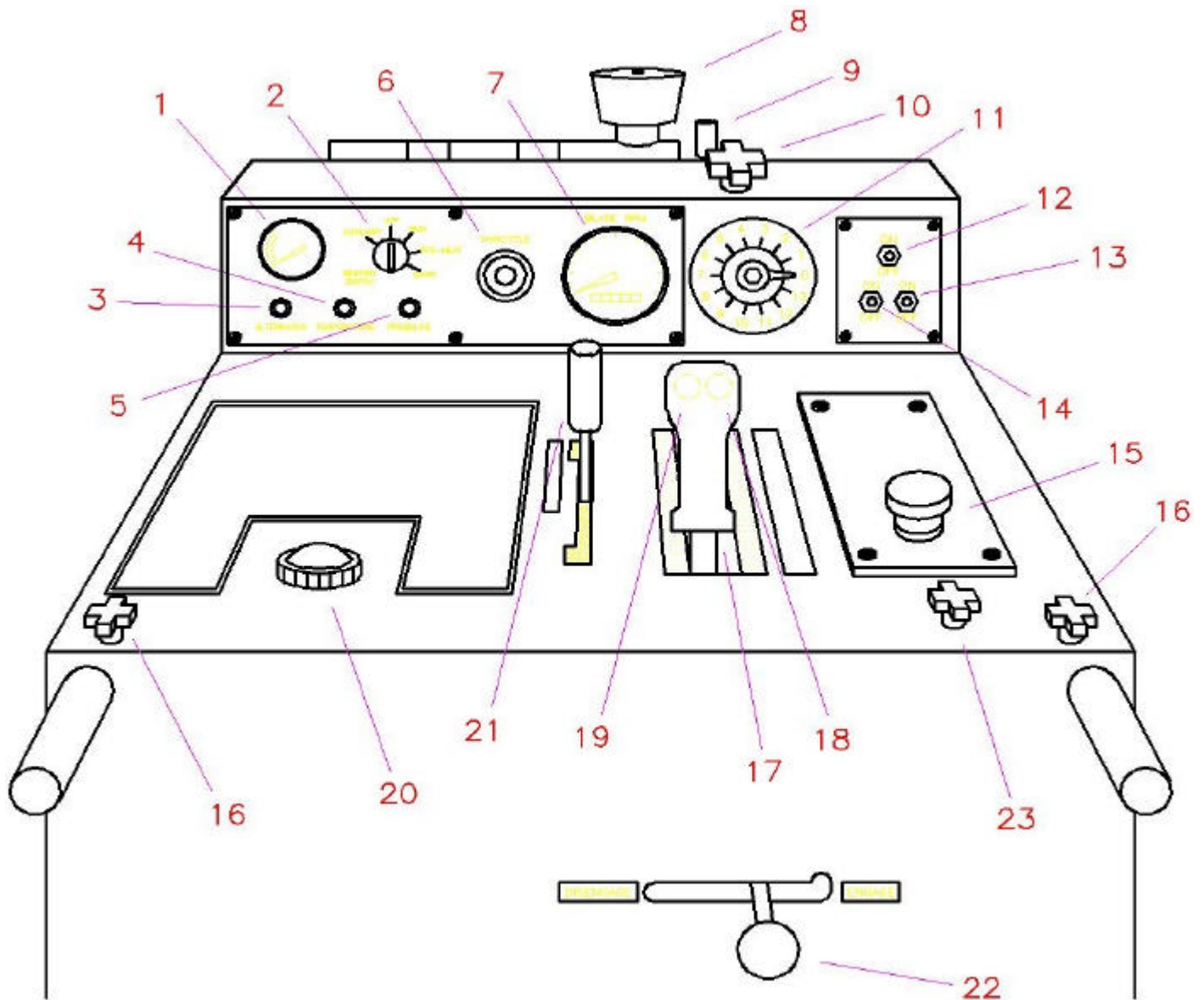

CC6560 Diesel Saw Controls Legend

- | | | | |
|----|-----------------------------------|----|--|
| 1 | Engine Temperature Gauge | 13 | Spotlight Switch (Optional) |
| 2 | Ignition Switch | 14 | Water Pump Switch (Optional) |
| 3 | Alternator Light (Orange) | 15 | Emergency Stop Button |
| 4 | Oil Temperature Light (Red) | 16 | Handle Lock Knobs |
| 5 | Oil Pressure Light (Green) | 17 | Speed Control Lever |
| 6 | Vernier Throttle Control | 18 | Lower Pushbutton |
| 7 | Blade Tachometer / Hour Meter | 19 | Raise Pushbutton |
| 8 | Pre-Cleaner | 20 | Fuel Tank Cap |
| 9 | Air Cleaner Restriction Indicator | 21 | Transmission Engagement Lever * |
| 10 | Depth Stop Knob | 22 | Transmission Engagement Lever ** |
| 11 | Cutting Depth Indicator | 23 | Lowering Speed Metering Valve (Optional) |
| 12 | Water Safety Switch (Optional) | | |
- * For Eaton Transmission Only
 ** Optional for Sundstrand Transmission Only

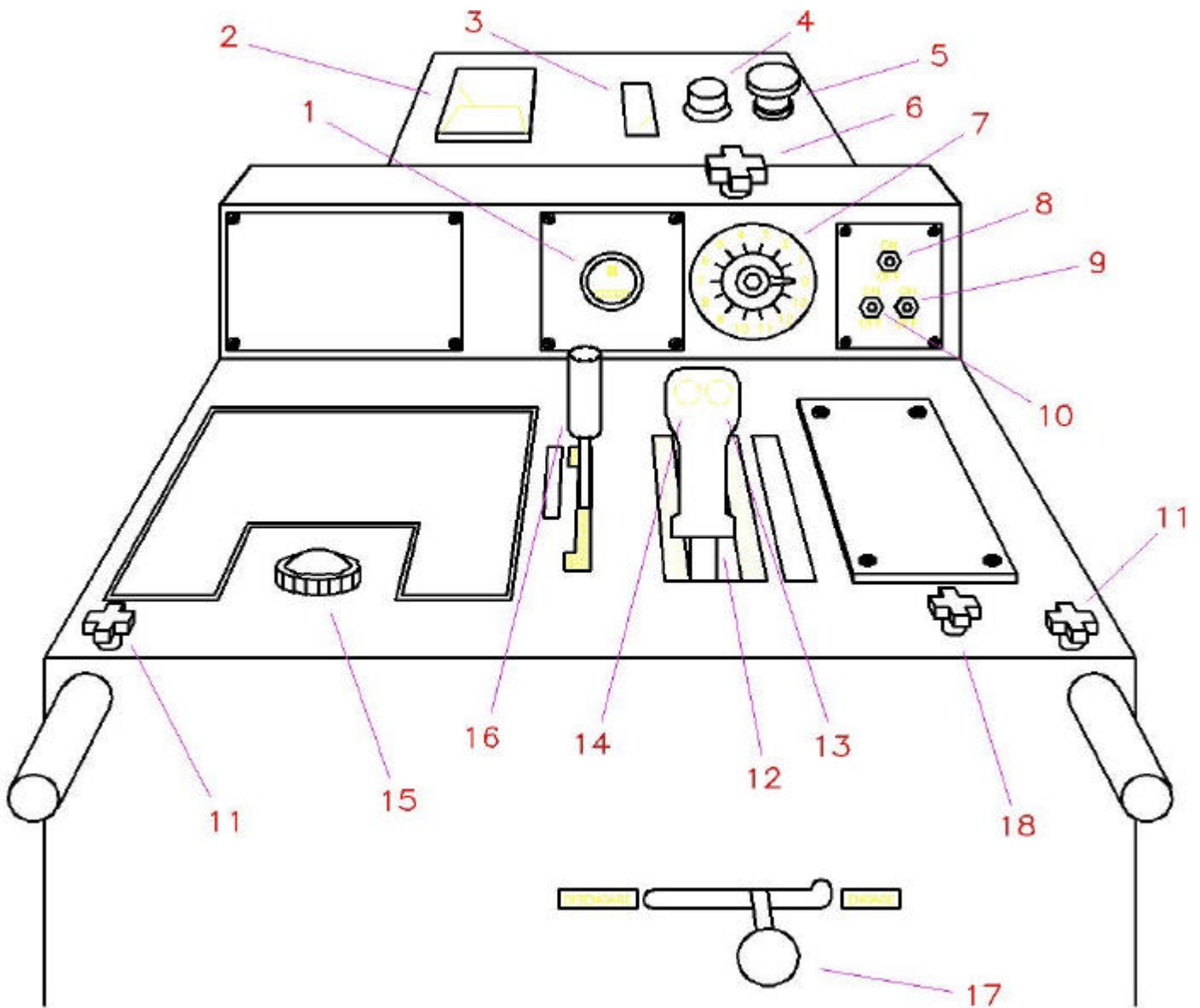

CC6500E Electric Saw Controls Legend

- | | | | |
|---|--------------------------------|----|--|
| 1 | Hour Meter | 10 | Water Pump Switch (Optional) |
| 2 | Amp Meter | 11 | Handle Lock Knobs |
| 3 | Battery Charge Meter | 12 | Speed Control Lever |
| 4 | Motor Start Button | 13 | Lower Pushbutton |
| 5 | Motor Stop Button | 14 | Raise Pushbutton |
| 6 | Depth Stop Knob | 15 | Fuel Tank Cap |
| 7 | Cutting Depth Indicator | 16 | Transmission Engagement Lever * |
| 8 | Water Safety Switch (Optional) | 17 | Transmission Engagement Lever ** |
| 9 | Spotlight Switch (Optional) | 18 | Lowering Speed Metering Valve (Optional) |
- * For Eaton Transmission Only
 ** For Sundstrand Transmission Only

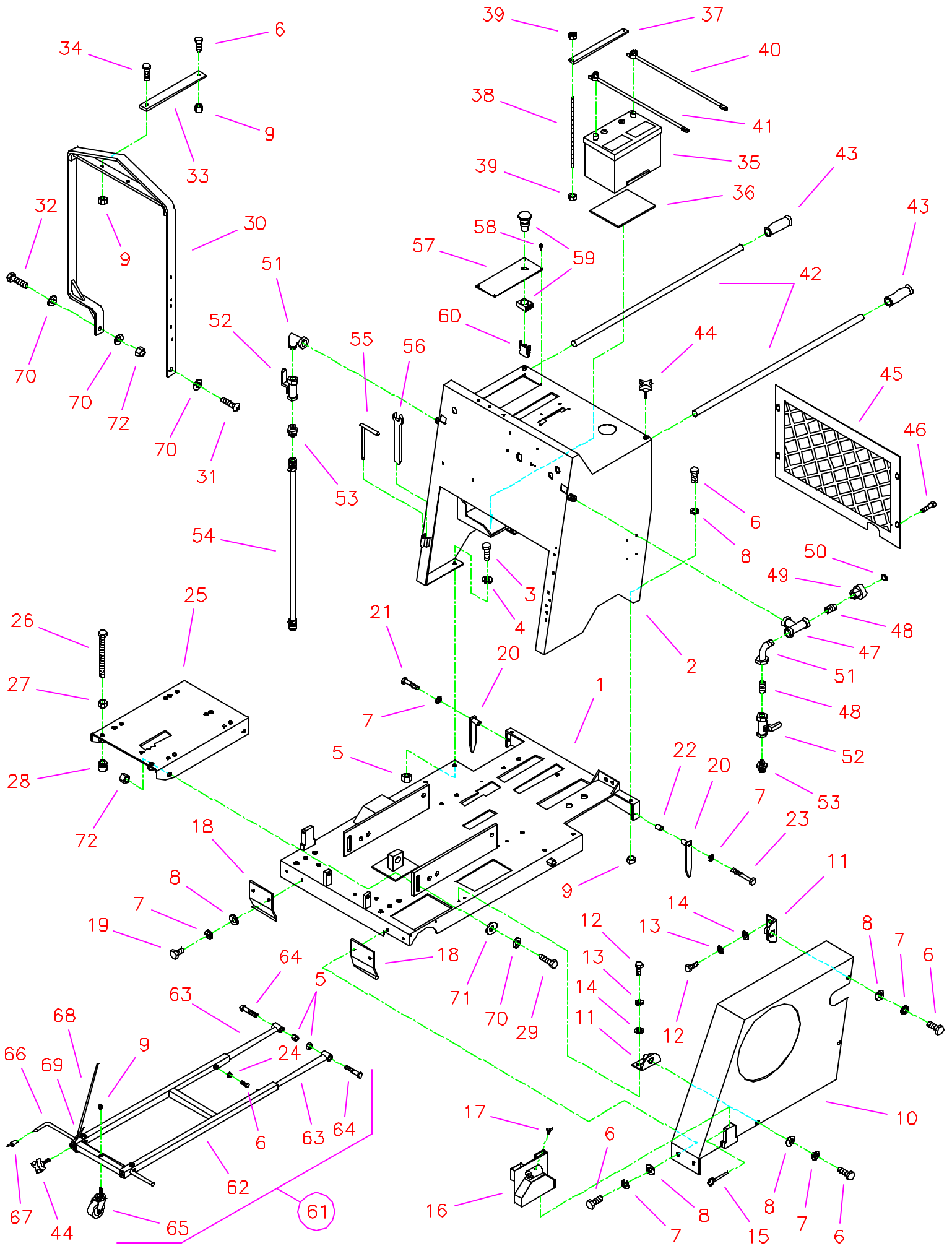

CC6500 Parts List
Drawing I
Frame Group

Diagram Number	Part No.	Qty. Req.	Description	Diagram Number	Part No.	Qty. Req.	Description
1	6010000	1	Frame Base	38	6010018	2	Rod, 1/4"-20 x 8-1/2"
2	6010001	1	Frame Upright	39	2900010	4	Lock Nut, 1/4"-20 Nylon
3	2900025	4	Capscrew, Hex Hd., 1/2"-13 x 1-1/4"	40	2800073	1	Battery Cable, Positive (Red)
4	2900058	4	Flat Washer, 1/2" SAE		2800071	1	Battery Cable, Positive (CC6500E)
5	2900026	6	Lock Nut, 1/2"-13 Nylon	41	2800072	1	Battery Cable, Negative (Black)
6	2900005	10	Capscrew, Hex Hd., 3/8"-16 x 1"	42	6010014	2	Handle Bar
7	2900006	9	Lock Washer, 3/8" Split	43	2500636	2	Handle Grip
8	2900014	9	Flat Washer, 3/8" SAE	44	2900234	4	Hand Lock Knob, 3/8"-16
9	2900018	5	Lock Nut, 3/8"-16 Nylon	45	6010015	1	Rear Cover Screen
10	6010002	1	Belt Guard without Hole	46	2900180	4	Machine Screw, Hex Washer Hd., 1/4"-20 x 1"
	6010003	1	Belt Guard with Hole				
11	6011110	3	Guard Mounting Tab	47	3200045	1	Pipe Tee, 1/2" NPT
12	2900019	6	Capscrew, Hex Hd., 5/16"-18 x 3/4"	48	3200008	2	Close Nipple, 1/2" NPT
13	2900031	6	Lock Washer, 5/16" Split	49	3200022	1	Fitting, 1/2" Female Pipe to 3/4" Female Garden Hose
14	2900022	6	Flat Washer, 5/16" SAE				
15	2900156	1	Lock Pin	50	3200025	1	Filter Hose Washer
16	6011046	1	Shaft/Flange Guard, Narrow	51	3200013	2	Street Elbow, 1/2" NPT
	6011187	1	Shaft/Flange Guard, Wide	52	3200027	2	Water Valve
17	2900307	1	Wing Screw, M6 x 16mm	53	3200155	2	Fitting, 1/2" Male Pipe to 3/4" Male Garden Hose
18	6010006	2	Skid Plate for 4-1/2" Dia. Flanges				
	6010007	2	Skid Plate for 6-1/4" Dia. Flanges	54	6010021	1	Hose Assembly, 42" Long
19	2900196	2	Capscrew, Hex Hd., 3/8"-16 x 3/4"	55	2900154	1	Bladeshift Lock-Pin
20	6010022	2	Rear Pointer	56	2500211	1	Bladeshift Wrench, 15/16"
21	2900047	1	Capscrew, Hex Hd., 3/8"-16 x 1-3/4"	57	6010019	1	Hydraulic Pump Cover Plate
22	6010515	1	Spacer, 7/8" Long	58	2900021	4	Tapscrew, Pan Hd., #10-24 x 3/8"
23	2900028	1	Capscrew, Hex Hd., 3/8"-16 x 2-3/4"	59	2800213	1	Emergency Stop Button
24	2900033	2	Hex Nut, 3/8"-16	60	2800229	1	Contact Block N.C.
25	6010011	1	Engine Base		2800214	1	Contact Block N.O. (Older Models)
26	2900104	2	Tap Bolt, Hex Hd., 5/8"-11 x 6"	61	6011200	1	Front Pointer Assembly
27	2900112	2	Hex Nut, 5/8"-11	62	6011201	1	Front Pointer Frame
28	2900446	2	Swivel Pad Nut, 5/8"-11	63	6011152	2	Front Pointer Arm
29	2900147	2	Capscrew, Hex Hd., 5/8"-11 x 1-3/4"	64	2900105	2	Capscrew, Hex Hd., 1/2"-13 x 2-3/4"
30	6010012	1	Frame Lift	65	2501199	1	Caster, Threaded Stem
31	2900286	1	Capscrew, Button Hd., 5/8"-11 x 2"	66	6010009	1	Front Pointer Rod
32	2900136	1	Capscrew, Hex Hd., 5/8"-11 x 2"	67	2500740	1	Pointer Cap
33	6010013	1	Frame Lift Brace	68	6010010	1	Pointer Cable
34	2900013	1	Capscrew, Hex Hd., 3/8"-16 x 1-1/4"	69	3200221	3	Cable Clamp
35	2700208	1	Battery, 12 Volt	70	2900002	6	Flat Washer, 5/8" SAE
36	6010016	1	Battery Pad	71	2900128	2	Flat Washer, 5/8" USS
37	6010017	1	Battery Top Brace	72	2900135	4	Lock Nut, 5/8"-11 Nylon

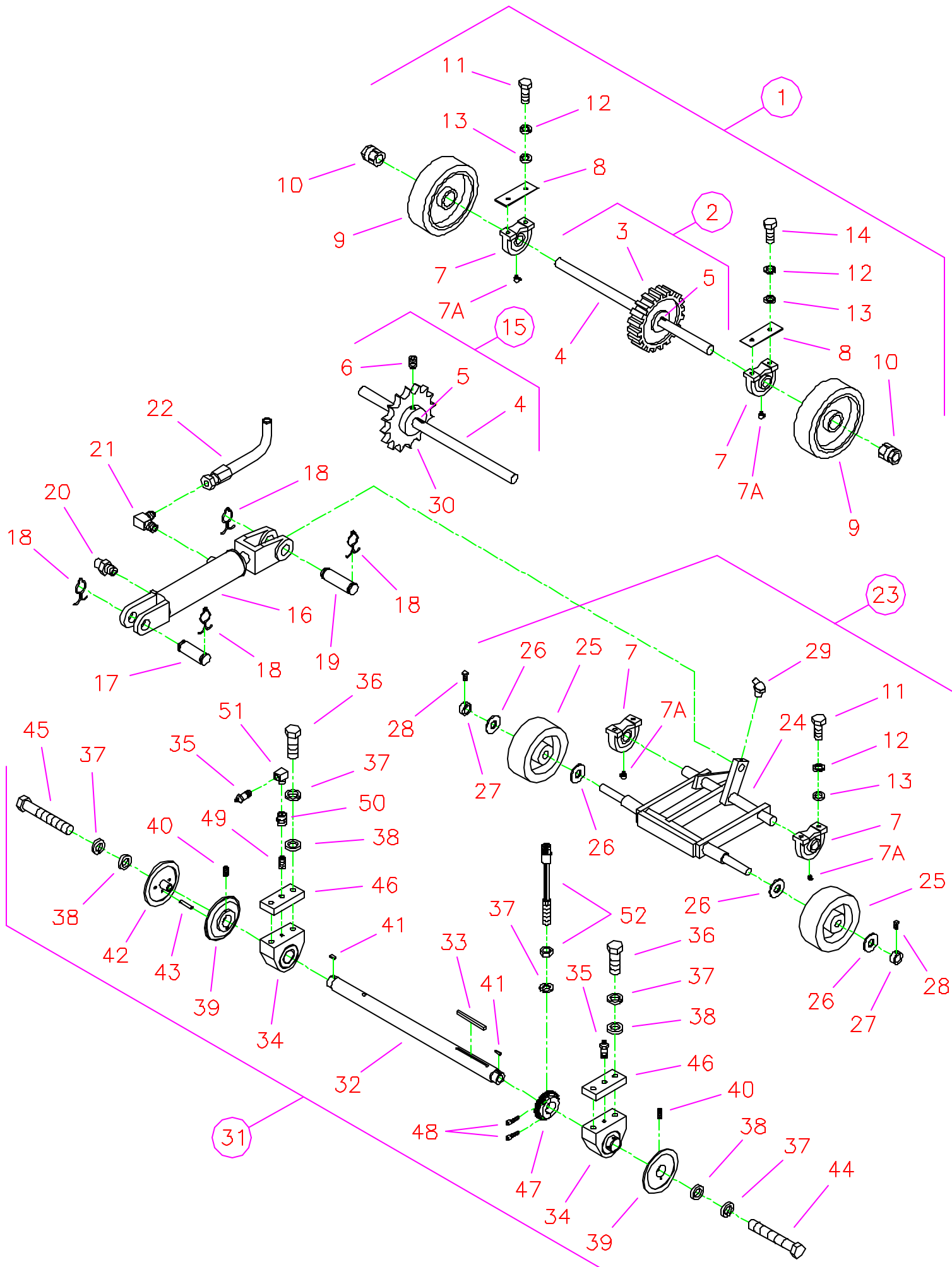

CC6500 Parts List
Drawing II
Blade Shaft and Axles Group

Diagram Number	Part No.	Qty. Req.	Description	Diagram Number	Part No.	Qty. Req.	Description
1	6010280	1	Rear Axle Assembly with 68 Tooth Gear (Includes #2 - #14)	30	2500267	1	Wheel Drive Sprocket, 35 Tooth
	6010282	1	Rear Axle Assembly with Chain Sprocket (Includes #4 - #15)	31	6010132	1	Blade Shaft Assembly with 4-1/2" Diameter Flanges for Gas/Electric Saws (Includes #32 - #46)
2	6010279	1	Rear Axle Weldment with 68 Tooth Gear (Includes #3 - #5)	6010133	1	Blade Shaft Assembly with 6-1/4" Diameter Flanges for Gas/Electric Saws (Includes #32 - #46)	
3	6010284	1	Wheel Drive Gear, 68 Tooth (New Models)	6010520	1	Blade Shaft Assembly with 4-1/2" Diameter Flanges for Diesel Saw CC6560 (Includes #32 - #51)	
	2500146	1	Wheel Drive Gear, 84 Tooth (Old Models)	6010521	1	Blade Shaft Assembly with 6-1/4" Diameter Flanges for Diesel Saw CC6560 (Includes #32 - #51)	
4	6010278	1	Rear Axle				
5	6010169	1	Key, 1/4" Sq. x 1-1/4"				
6	2900142	2	Setscrew, Soc. Hd., 5/16"-18 x 3/8"				
7	2500158	4	Pillow Block Bearing 1-1/4"	32	6010033	1	Blade Shaft for Gas/Electric Saws
7A	2900061	4	Grease Fitting, 1/4"-28 x 90°	6010504	1	Blade Shaft for Diesel Saw CC6560	
8	6010024	2	Rear Axle Bearing Spacer, 1/8"	33	6010034	1	Key, 3/8" Sq. x 5" for Gas/Electric Saws
9	2500873	2	Wheel, 10" Rear with 2" Bore	6012065	1	Key, 3/8" Sq. x 3-1/2" for Diesel Saw CC6560	
10	2500874	2	Trantorque Bushing, 1-1/4"	34	2500151	2	Blade Shaft Bearing, 1-3/4" (Includes #35)
11	2900025	6	Capscrew, Hex Hd., 1/2"-13 x 1-1/4"	35	2900198	2	Grease Fitting, 1/8" NPT
12	2900084	8	Lock Washer, 1/2" Split	36	2900147	4	Capscrew, Hex Hd., 5/8"-11 x 1-3/4"
13	2900058	8	Flat Washer, 1/2" SAE	37	2900113	7	Lock Washer, 5/8" Split
14	2900139	2	Capscrew, Hex Hd., 1/2"-13 x 1-3/4"	38	2900002	6	Flat Washer, 5/8" SAE
15	6010281	1	Rear Axle Weldment with Chain Sprocket (Includes #4 - #6, #30)	39	6010036	2	Inner Flange, 4-1/2" for 14" - 26" Blade Guards
16	2500178	1	Hydraulic Cylinder for Gas/Electric Saws	6010038	2	Inner Flange, 6-1/4" for 30" & 36" Blade Guards	
	2500177	1	Hydraulic Cylinder for Diesel Saw CC6560				
	2500278	1	(Seal Kit)	40	2900418	2	Setscrew, Soc. Hd., 5/16"-18 x 5/8"
17	6010031	1	Cylinder Pin, 3"	41	6010040	2	Key, 1/4" Sq. x 13/16"
18	2900064	4	Hair Pin Cotter, 3/4"	42	6010037	1	Outer Flange, 4-1/2" with Drive Pin for 14" - 26" Blade Guards
19	6010119	1	Cylinder Pin, 3-1/2"	6010039	1	Outer Flange, 6-1/4" with Drive Pin for 30" & 36" Blade Guards	
20	3200067	1	Cylinder Breather, 1/4" NPT				
21	3200057	1	Elbow, 1/4" Male Pipe to 1/4" Male JIC	43	2900197	1	Drive Pin, 3/8" Dia. x 2"
22	3200054	1	Hydraulic Hose Assembly, 32" Long	44	2900146	1	Capscrew, Hex Hd., 5/8"-11 x 4" Right Hand
23	6010195	1	Front Axle Assembly (Includes #7, #11 - #13, #24 - #29)	45	2900130	1	Capscrew, Hex Hd., 5/8"-11 x 4" Left Hand
24	6010032	1	Front Axle Weldment	46	6010035	2	Blade Shaft Bearing Spacer, 5/8"
25	2500182	2	Wheel, 8" Front	47	6010230	1	Shaft Tach Gear, Split
	2500673	2	(Roller Bearing and Seals Kit)	48	2900089	2	Capscrew, Soc. Hd., 1/4"-28 x 1"
26	2900145	4	Flat Washer, 1" USS	49	3200117	1	Close Nipple, 1/8" NPT for CC6560 Only
27	2500009	2	Set Collar, 1"	50	3200066	1	Hex Coupling, 1/8" NPT for CC6560 Only
28	2900431	2	Setscrew, Sq. Hd., 5/16"-18 x 1/2"	51	3200156	1	Street Elbow, 1/8" NPT for CC6560 Only
29	2900184	1	Grease Fitting, 1/4"-28 x 45°	52	2800169	1	Magnetic Sensor with Wire Connector and Hex Nut

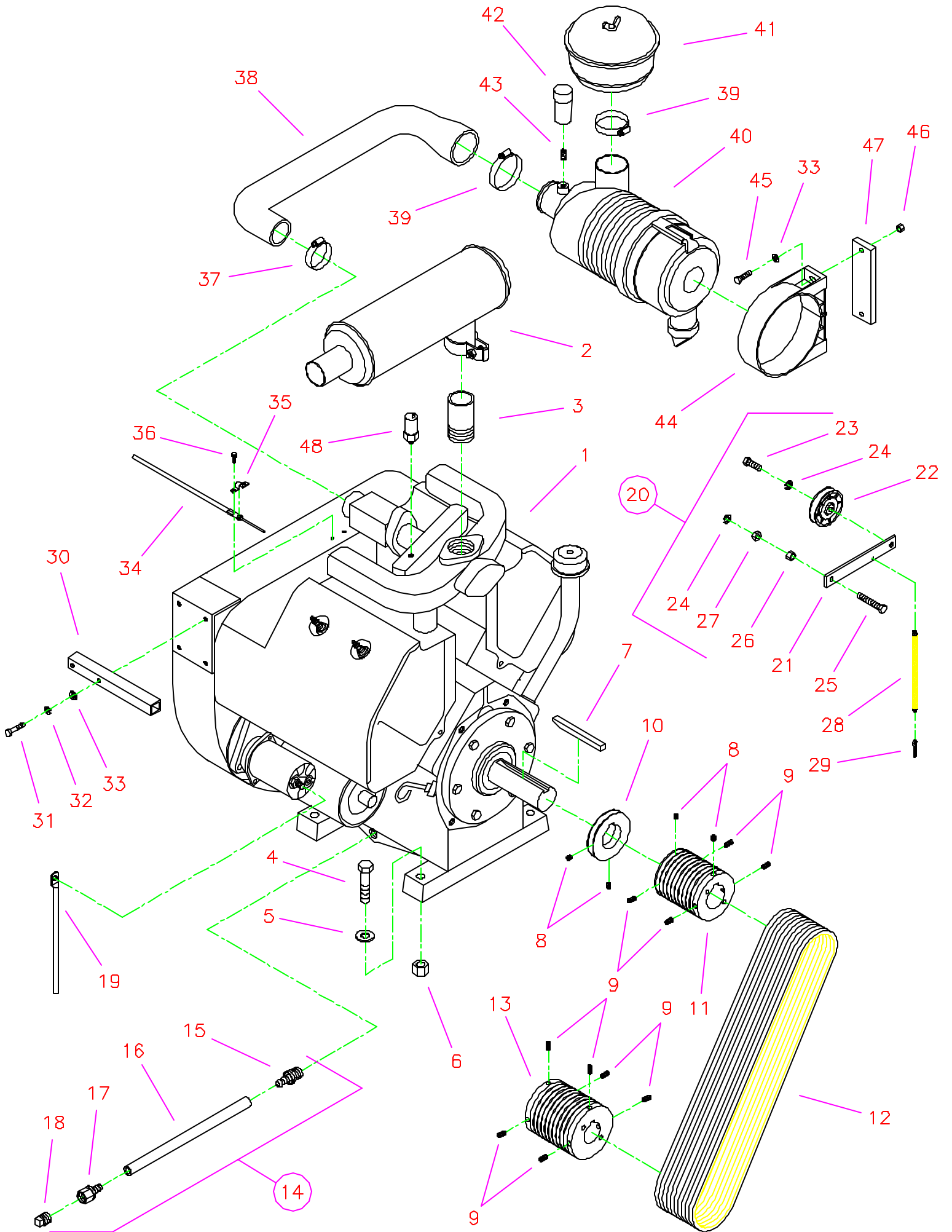

CC6500 Parts List
Drawing III
Engine Group

Diagram Number	Part No.	Qty. Req.	Description	Diagram Number	Part No.	Qty. Req.	Description
1	2600191	1	Engine, 65 Hp Wisconsin Model V465D1 (Includes #2 and #3)	26	2900018	1	Lock Nut, 3/8"-16 Nylon
				27	2900033	1	Hex Nut, 3/8"-16
2	2700179	1	Muffler, Horizontal with Clamp	28	2500195	1	Idler Spring, 3/8" x 7-3/4"
	2700600	1	Muffler, Vertical	29	2900055	1	Cotter Pin, 3/16" x 1"
	2700608	1	Rain Cap, 2-1/2" (not shown)	30	6010050	1	Pointer Stop
	2700609	1	Muffler Clamp, 2-1/2" (not shown)	31	2900508	2	Capscrew, Hex Hd., 5/16"-18 x 1-1/2"
3	3200051	1	Pipe Nipple	32	2900031	2	Lock Washer, 5/16" Split
4	2900195	4	Capscrew, Hex Hd., 5/8"-11 x 3"	33	2900022	4	Flat Washer, 5/16" SAE
5	2900002	4	Flat Washer, 5/8" SAE	34	2500376	1	Vernier Throttle Cable
6	2900135	4	Lock Nut, 5/8"-11 Nylon	35	2500940	1	Throttle Cable Clamp
7	6010042	1	Bevel End Key, 1/2" Sq. x 5-1/4" Long	36	2900411	2	Tapscrew, Hex Washer Hd., #10 x 3/4"
8	2900142	4	Setscrew, Soc. Hd., 5/16"-18 x 3/8"	37	3200095	1	Hose Clamp, #32
9	2900418	10	Setscrew, Soc. Hd., 5/16"-18 x 5/8"	38	2500470	1	Air Intake Hose
10	6010041	1	Accessory Drive Pulley, 4" O.D.	39	3200096	2	Hose Clamp, #40
11	6010153	1	Sheave, 4.00-10 Groove x 2" Bore	40	2501328	1	Air Cleaner, Plastic Style for Newer Saws
12	2500188	10	V-Belt, 3VX560		2500180	1	Air Cleaner, Metal Style for Older Saws
	2500262	2	Banded Belt, 3VX560 - 5 Strand		2501288	1	(Outer Primary Element for Plastic Air Cleaner)
13	6010155	1	Sheave, 4.12-10 Groove x 1-3/4" Bore for 14" Blade Guard		2500237	1	(Outer Primary Element for Metal Air Cleaner)
	6010157	1	Sheave, 4.50-10 Groove x 1-3/4" Bore for 20" and 26" Blade Guards		2501289	1	(Inner Safety Element for Plastic Air Cleaner)
	6010113	1	Sheave, 5.60-10 Groove with 1-3/4" QD Bushing for 30" and 36" Blade Guards		2500238	1	(Inner Safety Element for Metal Air Cleaner)
	2500209	1	(Sheave Only, 5.60-10 Groove)		2501185	1	(Rubber Dust Ejector Boot for Newer Plastic Style Air Cleaner)
	2500176	1	(Bushing Only, 1-3/4" QD with Capscrews)		2500239	1	(Rubber Dust Ejector Boot for Older Metal Style Air Cleaner)
14	6010177	1	Oil Drain Hose Assembly (Includes #15 - #18)	41	2500105	1	Pre-Cleaner with Clamp
					2500493	1	(Clear Plastic Bowl Only)
15	3200162	1	Fitting, 3/4" Male Pipe to 1/2" Push Lock	42	2500423	1	Restriction Indicator
16	6010245	1	Oil Drain Hose, 13" Long	43	3200117	1	Close Nipple, 1/8" NPT
17	3200163	1	Fitting, 1/2" Female Pipe to 1/2" Push Lock	44	2501329	1	Mounting Band for Newer Plastic Air Cleaner
18	3200160	1	Plug, 1/2" NPT		2500107	2	Mounting Strap for Older Metal Air Cleaner
19	2800073	1	Battery Cable, Positive (Red)	45	2900538	2	Capscrew, Hex Hd., 5/16"-18 x 1-3/4" for Newer Plastic Style Air Cleaner
20	6010194	1	Idler Assembly (Includes #21 - #29)		2900019	4	Capscrew, Hex Hd., 5/16"-18 x 3/4" for Older Metal Style Air Cleaner
21	6048218	1	Idler Arm				
22	2500074	1	Idler Pulley	46	2900039	2	Lock Nut, 5/16"-18 Nylon
23	2900013	1	Capscrew, Hex Hd., 3/8"-16 x 1-1/4"	47	6010519	1	Air Cleaner Spacer for Newer Plastic Style Air Cleaner Only
24	2900006	2	Lock Washer, 3/8" Split				
25	2900521	1	Tap Bolt, Hex Hd., 3/8"-16 x 2-1/2"	48	2800386	1	Vacuum Switch

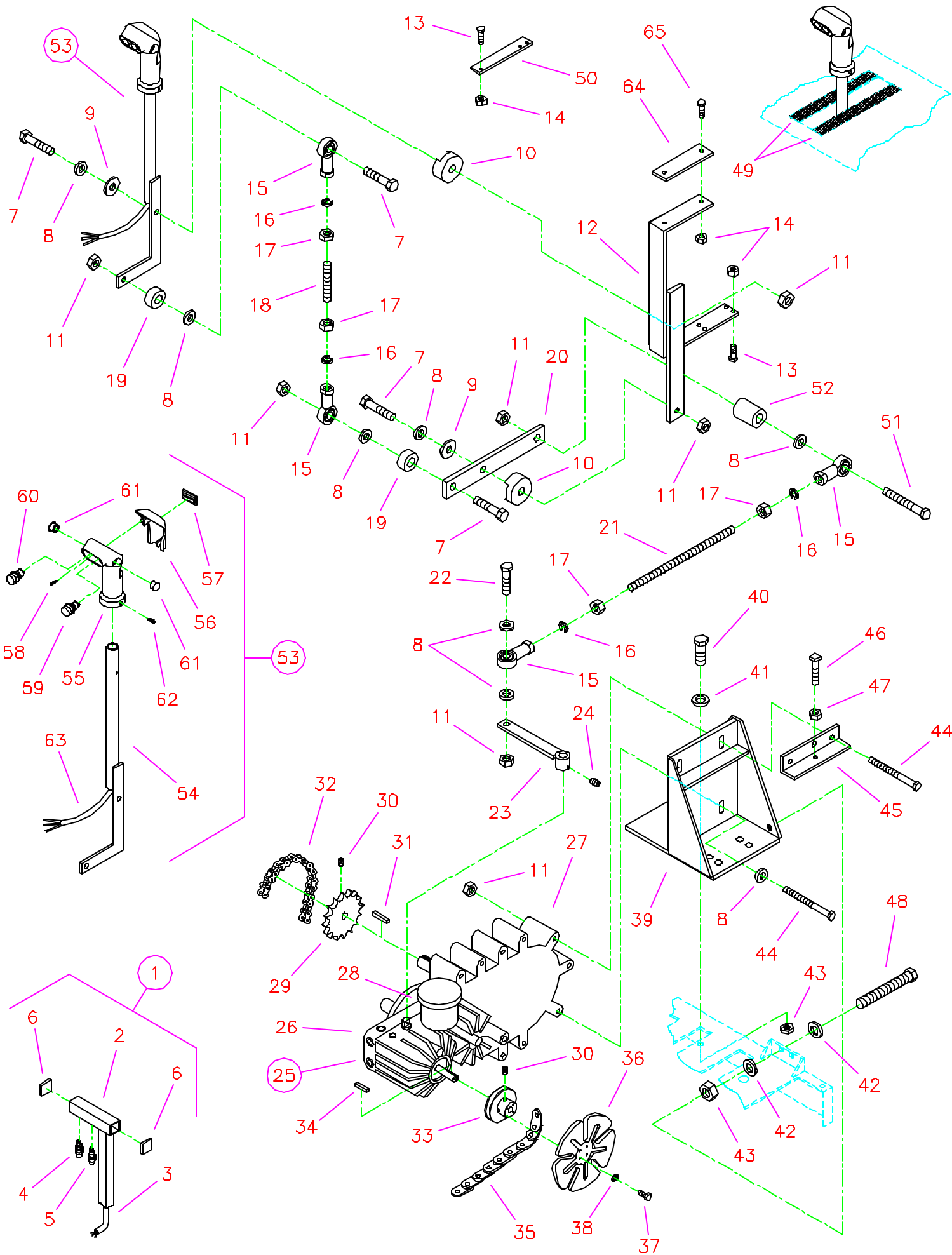

CC6500 Parts List
Drawing IV
Sundstrand Transmission Group

Diagram Number	Part No.	Qty. Req.	Description	Diagram Number	Part No.	Qty. Req.	Description
1	6010212	1	Speed Control Lever Assembly for Older Saws (Includes #2 - #6)	35	6010117	1	Link Belt
					2500169	1	(Link Belt Assembly Tool)
2	6010121	1	Speed Control Lever Only	36	2500519	1	Cooling Fan, 7"
3	6010108	1	Raise/Lower Wiring Harness	37	2900448	4	Machine Screw, Hex Hd., #10-32 x 1/2"
4	2800167	1	Push Button Switch, Lower				
5	2800166	1	Push Button Switch, Raise	38	2900038	4	Lock Washer, #10 Split
6	2500206	2	End Plug	39	6010118	1	Transmission Platform Weldment
7	2900047	4	Capscrew, Hex Hd., 3/8"-16 x 1-3/4"	40	2900139	1	Capscrew, Hex Hd., 1/2"-13 x 1-3/4"
8	2900014	9	Flat Washer, 3/8" SAE	41	2900127	1	Flat Washer, 1/2" USS
9	2900153	2	Friction Washer, 3/8"	42	2900058	2	Flat Washer, 1/2" SAE
10	6010055	2	Friction Spacer	43	2900026	2	Lock Nut, 1/2"-13 Nylon
11	2900018	10	Lock Nut, 3/8"-16 Nylon	44	2900160	4	Capscrew, Hex Hd., 3/8"-16 x 4"
12	6010122	1	Lever Support Weldment	45	6010120	1	Chain Tensioning Bracket
13	2900144	6	Capscrew, Hex Hd., 1/4"-20 x 3/4"	46	2900140	1	Setscrew, Sq. Hd., 5/16"-18 x 1-1/2"
14	2900010	8	Lock Nut, 1/4"-20 Nylon	47	2900141	1	Hex Nut, 5/16"-18
15	2500152	4	Rod End, 3/8"-24	48	2900542	1	Tap Bolt, Hex Hd., 1/2"-13 x 3-1/2"
16	2900006	4	Lock Washer, 3/8" Split	49	6010101	2	Edge Trim
17	2900148	4	Hex Nut, 3/8"-24	50	6010166	2	Gate Cover Bar
18	6010167	1	Rod, 3/8"-24 x 2-1/4"	51	2900028	1	Capscrew, Hex Hd., 3/8"-16 x 2-3/4"
19	2500007	2	Set Collar, 1/2"	52	6010141	1	Linkage Spacer, 1-3/8"
20	6010123	1	Linkage Lever	53	6010317	1	Speed Control Lever Assembly for Newer Saws (Includes #54 - #63)
21	6010168	1	Rod, 3/8"-24 x 10"				
22	2900029	1	Capscrew, Hex Hd., 3/8"-16 x 1-1/2"	54	6010315	1	Speed Control Lever Only
23	6010129	1	Shift Lever	55	2501280	1	Control Grip Body
24	2900429	1	Setscrew, Soc. Hd., 5/16"-24 x 1/2"	56	2501281	1	Control Grip Cover
25	2600021	1	Hydrostatic Transaxle Assembly (Includes #26 - #28)	57	2500644	1	Plug, Rectangular
				58	2900452	1	Screw, Oval Head, #4 x 5/8"
26	2600033	1	Hydrostatic Transmission Only	59	2800372	1	Pushbutton Switch, Raise
27	2600085	1	Transaxle Gearbox Only	60	2800373	1	Pushbutton Switch, Lower
28	2700357	1	Oil Reservoir Only	61	2500694	2	Plug, 5/8" Hole
29	6010127	1	Transmission Sprocket, 19 Tooth	62	2900453	1	Setscrew, Soc. Hd., M5 x 12mm
30	2900142	4	Setscrew, Soc. Hd., 5/16"-18 x 3/8"	63	2800393	1	Wiring Harness, Hydraulic Pump
31	6010169	1	Key, 1/4" Sq. x 1-1/4"	64	2501339	1	Rubber Support Mount for Diesel Saw CC6560 Only
32	6010130	1	#50 Chain, 50 Pitch				
33	6011037	1	Transmission Pulley	65	2900144	2	Capscrew, Hex Hd., 1/4"-20 x 3/4"
34	6010170	1	Key, 3/16" Sq. x 1"				
					2900008	2	Capscrew, Hex Hd., 1/4"-20 x 1" for Support without Rubber Item #64
							for Support with Rubber Item #64

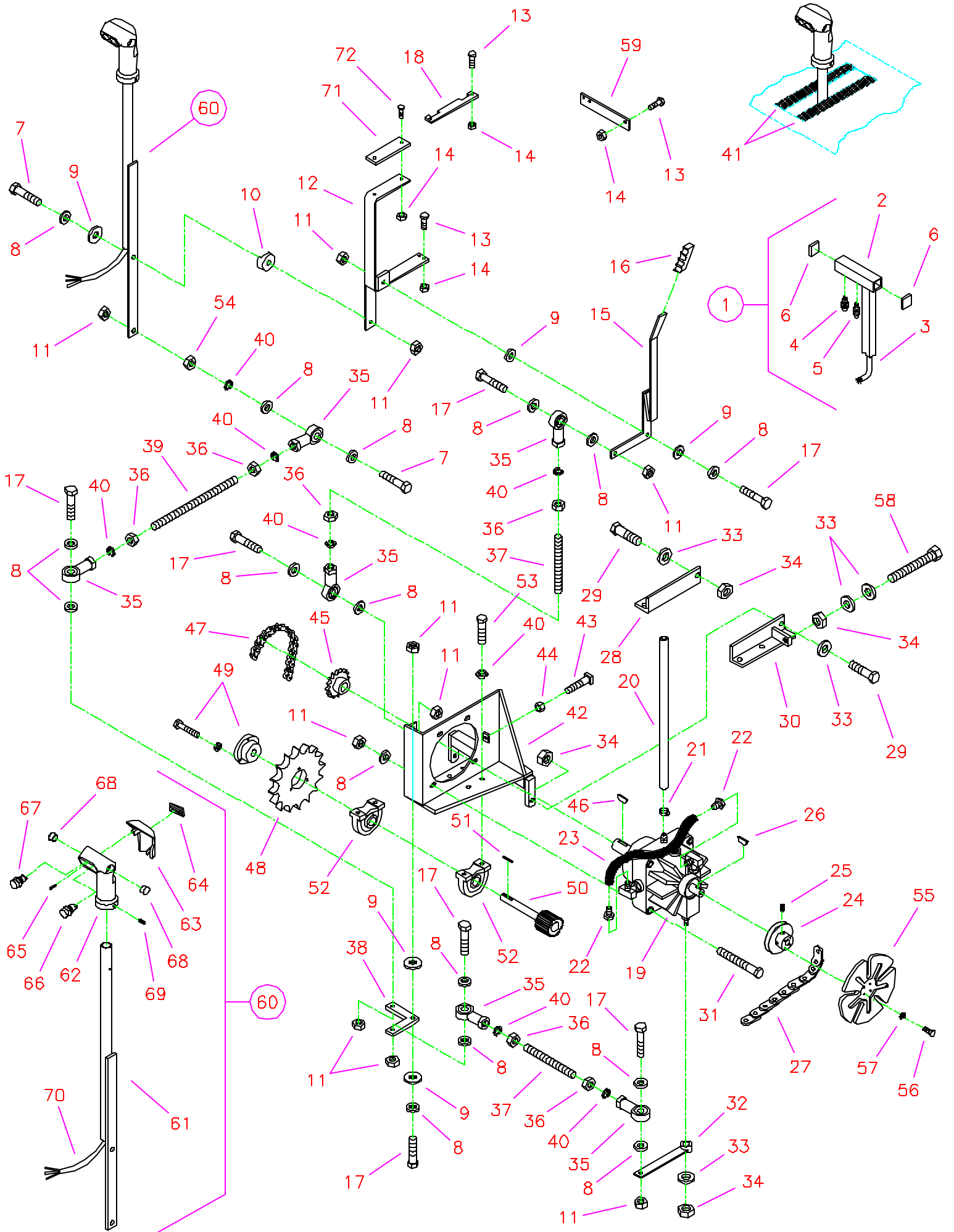

CC6500 Parts List
Drawing V
Eaton Transmission Group

Diagram Number	Part No.	Qty. Req.	Description	Diagram Number	Part No.	Qty. Req.	Description
1	6010192	1	Speed Control Lever Assembly for Older Saws (Includes #2 - #6)	40	2900006	11	Lock Washer, 3/8" Split
				41	6010101	2	Edge Trim
2	6010054	1	Speed Control Lever Only	42	6010068	1	Transmission Platform Weldment
3	6010108	1	Raise/Lower Wiring Harness	43	2900140	1	Setscrew, Sq. Hd., 5/16"-18 x 1-1/2"
4	2800167	1	Push Button Switch, Lower	44	2900141	1	Hex Nut, 5/16"-18
5	2800166	1	Push Button Switch, Raise	45	2500150	1	Sprocket, 11 Tooth with Setscrew
6	2500206	2	End Plug	46	2900063	1	Woodruff Key #5, 1/8" Wide x 5/8" Dia.
7	2900047	2	Capscrew, Hex Hd., 3/8"-16 x 1-3/4"	47	6010069	1	#40 Chain, 56 Pitch
8	2900014	19	Flat Washer, 3/8" SAE	48	2500148	1	Sprocket, 45 Tooth
9	2900153	5	Friction Washer, 3/8"	49	2500149	1	Sprocket Bushing with Fasteners
10	6010055	1	Friction Spacer	50	6013101	1	Transmission Jackshaft, 11 Tooth (New Models)
11	2900018	13	Lock Nut, 3/8"-16 Nylon				
12	6010056	1	Lever Support Weldment		6010080	1	Transmission Jackshaft, 15 Tooth (Old Models)
13	2900144	6	Capscrew, Hex Hd., 1/4"-20 x 3/4"				
14	2900010	8	Lock Nut, 1/4"-20 Nylon	51	6048229	1	Key, 3/16" Sq. x 1-1/4"
15	6010057	1	Engagement Lever Weldment	52	2500159	2	Pillow Block Bearing, 3/4"
16	2500002	1	Hand Grip	53	2900005	4	Capscrew, Hex Hd., 3/8"-16 x 1"
17	2900029	7	Capscrew, Hex Hd., 3/8"-16 x 1-1/2"	54	2900033	1	Hex Nut, 3/8"-16
18	6010058	1	Gate Plate	55	2500519	1	Cooling Fan, 7"
19	2600068	1	Hydrostatic Transmission	56	2900448	4	Machine Screw, Hex Hd. #10-32 x 1/2"
20	6010059	1	Return Hose, 3/8" I.D. x 19" Long				
21	3200062	1	Hose Clamp #4	57	2900038	4	Lock Washer, #10 Split
22	3200046	2	Fitting, 3/8 Female JIC to 3/8" Push Lock	58	2900542	1	Tap Bolt, Hex Hd., 1/2"-13 x 3-1/2"
23	6010060	1	Oil Recirculation Hose, 3/8" I.D. x 9"	59	6010166	1	Gate Cover Bar
24	6010061	1	Transmission Pulley	60	6010316	1	Speed Control Lever Assembly for Newer Saws (Includes #61 - #70)
25	2900142	2	Setscrew, Soc. Hd., 5/16"-18 x 3/8"				
26	2900143	1	Woodruff Key #61, 3/16" Wide x 5/8" Dia.	61	6010314	1	Speed Control Lever Only
27	6010063	1	Link Belt	62	2501280	1	Control Grip Body
	2500169	1	(Link Belt Assembly Tool)	63	2501281	1	Control Grip Cover
28	6010027	1	Mount Foot, Right Hand	64	2500644	1	Plug, Rectangular
29	2900139	2	Capscrew, Hex Hd., 1/2"-13 x 1-3/4"	65	2900452	1	Screw, Oval Head, #4 x 5/8"
30	6010028	1	Mount Foot, Left Hand	66	2800372	1	Pushbutton Switch, Raise
31	2900035	4	Capscrew, Hex Hd., 3/8"-16 x 3"	67	2800373	1	Pushbutton Switch, Lower
32	6010064	1	Shift Lever	68	2500694	2	Plug, 5/8" Hole
33	2900058	5	Flat Washer, 1/2" SAE	69	2900453	1	Setscrew, Soc. Hd., M5 x 12mm
34	2900026	4	Lock Nut, 1/2"-13 Nylon	70	2800393	1	Wiring Harness, Hydraulic Pump
35	2500152	6	Rod End, 3/8"-24	71	2501339	1	Rubber Support Mount for Diesel Saw CC6560 Only
36	2900148	6	Hex Nut, 3/8"-24				
37	6010065	2	Rod, 3/8"-24 x 3-1/2"	72	2900144	2	Capscrew, Hex Hd., 1/4"-20 x 3/4" for Support without Rubber Item #71
38	6010067	1	Bell Crank				
39	6010066	1	Rod, 3/8"-24 x 7"		2900008	2	Capscrew, Hex Hd., 1/4"-20 x 1" for Support with Rubber Item #71

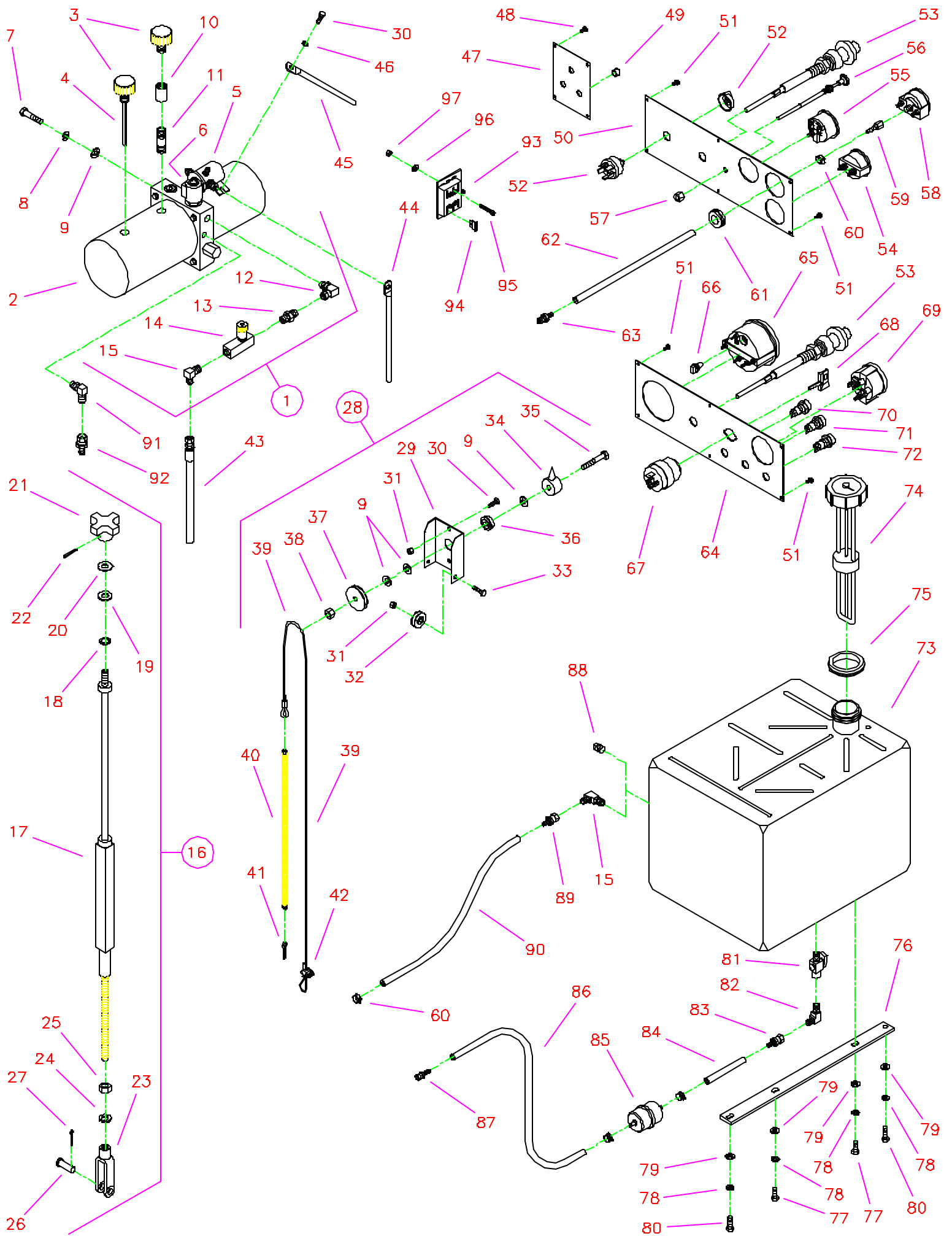

CC6500 Parts List
Drawing VI
Controls Group

Diagram Number	Part No.	Qty. Req.	Description	Diagram Number	Part No.	Qty. Req.	Description
1	6010213	1	Hydraulic Pump Assy. (Includes #2 - #15)	53	2500376	1	Vernier Throttle Cable
2	2600070	1	Hydraulic Pump Unit (Includes #3 - #6)	54	2800271	1	Volt Meter (Gas Engine)
3	2700321	2	Breather Cap, 3/8" NPT		2800059	1	Amp Meter (Older Models)
4	2701815	1	Dipstick	55	2800064	1	Hour Meter (Gas Engine)
5	2700169	1	Solenoid, Motor	56	2500186	1	Choke Cable (Gas Engine)
6	2700243	1	Valve Coil	57	2900148	1	Hex Nut, 3/8"-24
	2700244	1	Valve Stem	58	2500179	1	Oil Pressure Gauge (Gas Engine)
7	2900047	2	Capscrew, Hex Hd., 3/8"-16 x 1-3/4"	59	3200188	1	Fitting, 1/8" Female Pipe to 1/4" Hose Barb
8	2900006	2	Lock Washer, 3/8" Split	60	3200062	2	Hose Clamp #4
9	2900014	5	Flat Washer, 3/8" SAE	61	2500203	2	Grommet
10	3200120	1	Pipe Coupling, 3/8" NPT	62	6010100	1	Oil Pressure Line Hose, 1/4" I.D. x 32"
11	3200123	1	Pipe Nipple, 3/8" NPT x 2"	63	3200064	1	Fitting, 1/4" Male SAE to 1/4" Push Lock
12	3200115	1	Elbow, 3/8" O-Ring to 1/4" Female Pipe	64	6013093	1	Gauge Panel for Diesel Saw Only
13	3200060	1	Hex Nipple, 1/4" NPT	65	2800168	1	Blade Shaft Tach/Hour Meter
14	3200056	1	Flow Control Valve, 1/4" NPT	66	2800267	1	Light, Wedge Base
15	3200057	2	Elbow, 1/4" Male Pipe to 1/4" Male JIC	67	2700783	1	Ignition Switch with Key (Diesel Engine)
16	6010215	1	Depth Stop Assembly (Includes #17 - #27)	68	2701261	1	Ignition Key Only
17	6010097	1	Depth Stop Weldment	69	2700784	1	Engine Temperature Gauge (Diesel Engine)
18	2900133	1	Wave Washer		2701736	1	(Bulb Only)
19	2900058	1	Flat Washer, 1/2" SAE	70	2700786	1	Oil Pressure Light (Green)
20	2900239	1	Friction Washer, 1/2"		2700923	1	(Bulb Only)
21	6010095	1	Depth Stop Knob	71	2700787	1	Oil Temperature Light (Red)
22	2900132	1	Roll Pin, 3/16" x 1-1/4"		2700923	1	(Bulb Only)
23	2900158	1	Yoke, 1/2"-13	72	2700785	1	Alternator Light (Orange)
24	2900084	1	Lock Washer, 1/2" Split		2700923	1	(Bulb Only)
25	2900037	1	Hex Nut, 1/2"-13	73	2500650	1	Fuel Tank, 9 Gallon
26	2900007	1	Clevis Pin, 1/2" Dia. x 1-3/8"	74	2500649	1	Fuel Tank Cap with Gauge
27	2900004	1	Cotter Pin, 1/8" x 1"	75	2500205	1	Fuel Tank Grommet
28	6010214	1	Depth Indicator Assembly (Includes #9, #29 - #42)	76	6010257	2	Fuel Tank Mount Bar
29	6010092	1	Depth Indicator Mount Bracket	77	2900019	4	Capscrew, Hex Hd., 5/16"-18 x 3/4"
30	2900144	3	Capscrew, Hex Hd., 1/4"-20 x 3/4"	78	2900031	8	Lock Washer, 5/16" Split
31	2900010	4	Lock Nut, 1/4"-20 Nylon	79	2900022	8	Flat Washer, 5/16" SAE
32	2500155	2	Cable Pulley, 1-1/4"	80	2900138	4	Capscrew, Hex Hd., 5/16"-18 x 1"
33	2900008	2	Capscrew, Hex Hd., 1/4"-20 x 1"	81	3200108	1	Fuel Shut-off Valve
34	6010091	1	Depth Indicator Pointer	82	3200057	1	Elbow, 1/4" Male Pipe to 1/4" Male JIC (Gas)
35	2900079	1	Capscrew, Hex Hd., 3/8"-16 x 2-1/4"		3200012	1	Street Elbow, 1/4" NPT (Diesel)
36	2500145	1	Flange Bearing, 3/8"	83	3200091	1	Fitting, 1/4" Female JIC to 1/4" Push Lock (Gas)
37	6010093	1	Cable Pulley, 2"		3200202	1	Fitting, 1/4" Male Pipe to 5/16" Push Lock (Diesel)
38	2900018	1	Lock Nut, 3/8"-16 Nylon	84	6010218	1	Fuel Line Hose, 1/4" I.D. x 4" Long (Gas)
39	6010094	1	Depth Indicator Cable with Crimp, 48"		6013095	1	Fuel Line Hose, 5/16" I.D. x 4" Long (Diesel)
40	2500196	1	Spring, 3/8" x 15"	85	2500201	1	Fuel Filter, 1/4" with Clamps (Gas)
41	2900055	1	Cotter Pin, 3/16" x 1"		2500474	1	Fuel Filter, 5/16" with Clamps (Diesel)
42	2500214	1	Cable Clamp	86	6010103	1	Fuel Line Hose, 1/4" I.D. x 28" Long (Gas)
43	3200054	1	Hydraulic Hose Assembly, 32" Long		6013096	1	Fuel Line Hose, 5/16" I.D. x 28" Long (Diesel)
44	2800095	1	Solenoid Cable (Red)	87	3200065	1	Fitting, 1/8" Male Pipe to 1/4" Push Lock (Gas)
	2800071	1	Battery Cable, Positive (CC6500E)		3200062	1	Hose Clamp #4 (Diesel)
45	2800182	1	Negative Ground Cable (Black)	88	3200206	1	Pipe Plug, 1/4" NPT (Gas)
46	2900024	1	Lock Washer, 1/4" Split	89	3200091	1	Fitting, 1/4" Female JIC to 1/4" Push Lock (Diesel)
47	6010098	1	Switch Plate	90	6010103	1	Fuel Line Hose, 1/4" I.D. x 28" Long (Diesel)
48	2900445	6	Tapscrew, Flat Hd., #10-24 x 1/2"	91	3200116	1	Elbow, 1/4" O-Ring to 3/8" Male JIC
49	2500204	3	Plug, 1/2" Hole	92	3200046	1	Fitting, 3/8" Female JIC to 3/8" Push Lock
50	6010238	1	Gauge Panel for Gas Saw Only	93	2800388	1	Fuse Panel, 6 Circuit
51	2900021	4	Tapscrew, Pan Hd., #10-24 x 3/8"	94	2800389	6	Fuse, 10 Amp Red ATO/ATC
52	2500220	1	Ignition Switch (Gas Engine)	95	2900451	2	Capscrew, Soc. Hd., #10-24 x 1-1/4"
				96	2900016	2	Flat Washer, #10 USS
				97	2900017	2	Lock Nut, #10-24 Nylon

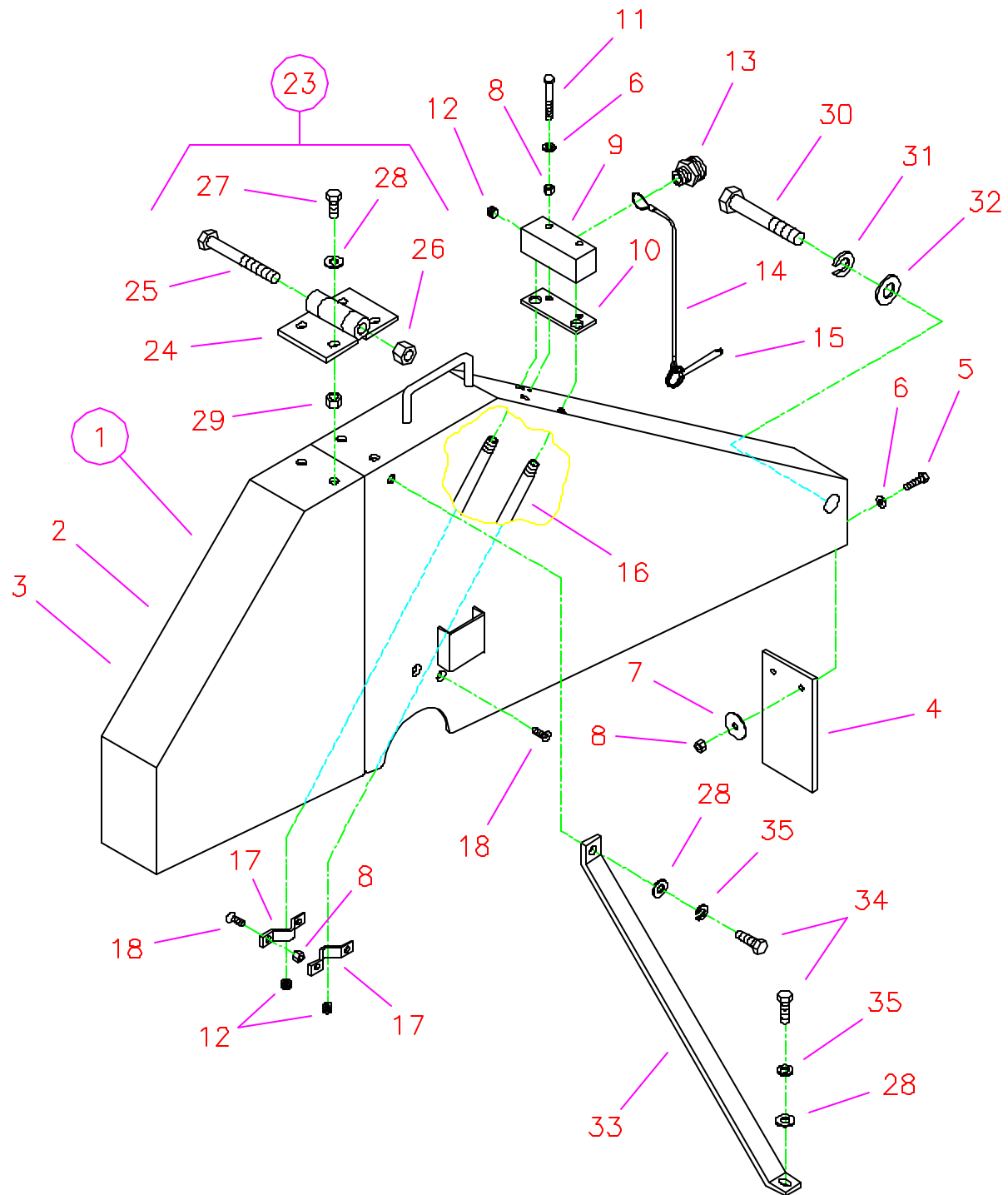
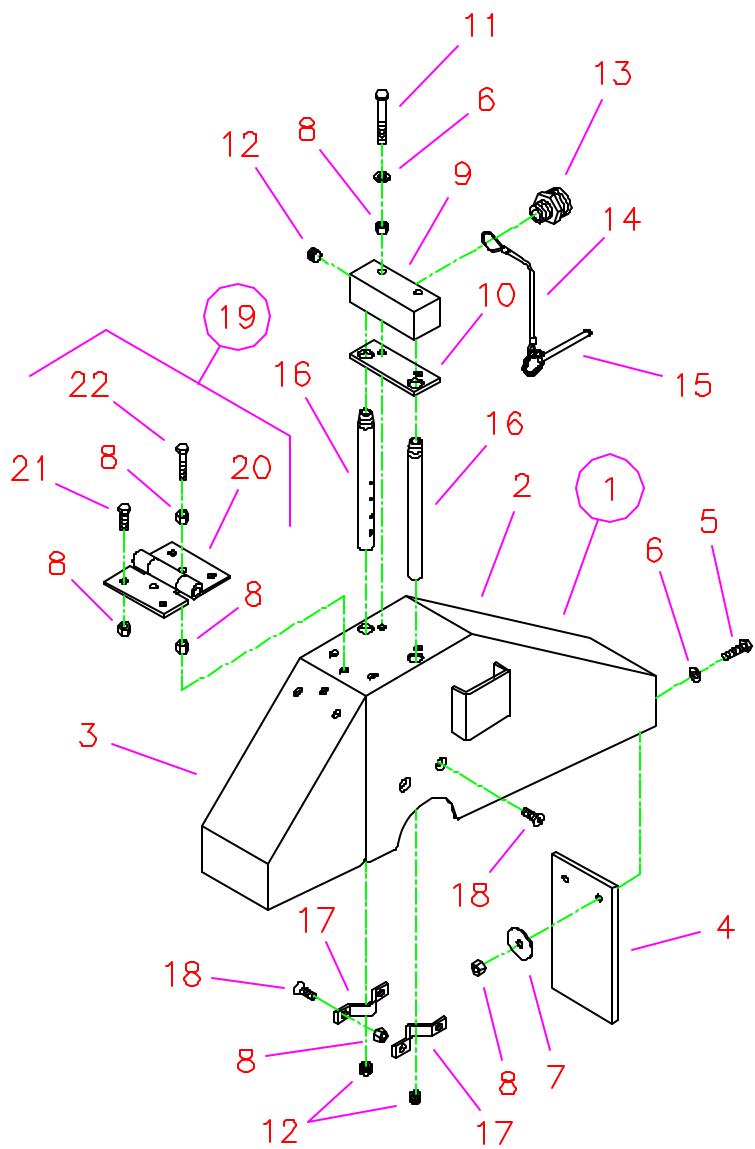

CC6500 Parts List
Drawing VII
Blade Guard Assembly

Diagram Number	Part No.	Qty. Req.	Description	Diagram Number	Part No.	Qty. Req.	Description
1	6010070	1	14" Blade Guard Assembly (Includes #2 - #22)	15	2900156	1	Lock Pin Only
	6010072	1	20" Blade Guard Assembly (Includes #2 - #21)	16	6048283	2	Water Tube for 14" Blade Guard
	6010074	1	26" Blade Guard Assembly (Includes #2 - #18, #23)		6010085	2	Water Tube for 20" Blade Guard
	6010076	1	30" Blade Guard Assembly (Includes #2 - #18, #23)		6010086	2	Water Tube for 26" Blade Guard
	6010078	1	36" Blade Guard Assembly (Includes #2 - #18, #23 - #32)		6010087	2	Water Tube for 30" Blade Guard
					6010088	2	Water Tube for 36" Blade Guard
2	6010071	1	14" Blade Guard Front & Rear Only	17	6048155	2	Water Tube Clamp
	6010073	1	20" Blade Guard Front & Rear Only	18	2900020	4	Capscrew, Flat Hd., 1/4"-20 x 3/4"
	6010075	1	26" Blade Guard Front & Rear Only	19	6048150	1	Hinge Assembly for 14" Blade Guard (Includes #8, #20 - #22)
	6010077	1	30" Blade Guard Front & Rear Only		6010251	1	Hinge Assembly for 20" Blade Guard (Includes #8, #20, #21)
	6010079	1	36" Blade Guard Front & Rear Only	20	2500270	1	Hinge Only
3	6010304	1	14" Blade Guard Front Only	21	2900144	6	Capscrew, Hex Hd., 1/4"-20 x 3/4"
	6010305	1	20" Blade Guard Front Only	22	2900052	1	Capscrew, Hex Hd., 1/4"-20 x 1-1/4"
	6010306	1	26" Blade Guard Front Only	23	6010263	1	Hinge Assembly for 26"-36" Blade Guards (Includes #24 - #29)
	6010307	1	30" Blade Guard Front Only	24	6010125	1	Hinge Only
	6010308	1	36" Blade Guard Front Only	25	2900509	1	Capscrew, Hex Hd., 1/2"-13 x 4"
4	6010081	1	Splash Flap	26	2900026	1	Lock Nut, 1/2"-13 Nylon
5	2900008	2	Capscrew, Hex Hd., 1/4"-20 x 1"	27	2900013	4	Capscrew, Hex Hd., 3/8"-16 x 1-1/4"
6	2900009	4	Flat Washer, 1/4" SAE	28	2900014	6	Flat Washer, 3/8" SAE
7	2900083	2	Fender Washer, 1/4" x 1-1/4"	29	2900018	4	Lock Nut, 3/8"-16 Nylon
8	2900010	15	Lock Nut, 1/4"-20 Nylon	30	2900291	1	Capscrew, Hex Hd., 5/8"-18 x 4"
9	6010261	1	Manifold for 14" - 30" Blade Guards	31	2900113	1	Lock Washer, 5/8" Split
	6010264	1	Manifold for 36" Blade Guard	32	2900002	1	Flat Washer, 5/8" SAE
10	2500830	1	Manifold Gasket	33	6010134	1	Blade Guard Brace for 30" & 36" Blade Guards on Gas/Electric Saws
11	2900294	2	Capscrew, Hex Hd., 1/4"-20 x 2"		6010511	1	Blade Guard Brace for 30" & 36" Blade Guards on Diesel Saw CC6560
12	3200001	3	Pipe Plug, 1/8" NPT				
13	3200002	1	Fitting, 3/4" Male Garden Hose to 3/8" Male Pipe	34	2900005	2	Capscrew, Hex Hd., 3/8"-16 x 1"
				35	2900006	2	Lock Washer, 3/8" Split
14	2900278	1	Lanyard with Lock Pin for 14" & 20" Blade Guards				
	2900279	1	Lanyard with Lock Pin for 26" & 30" Blade Guards				
	2900280	1	Lanyard with Lock Pin for 36" Blade Guard				

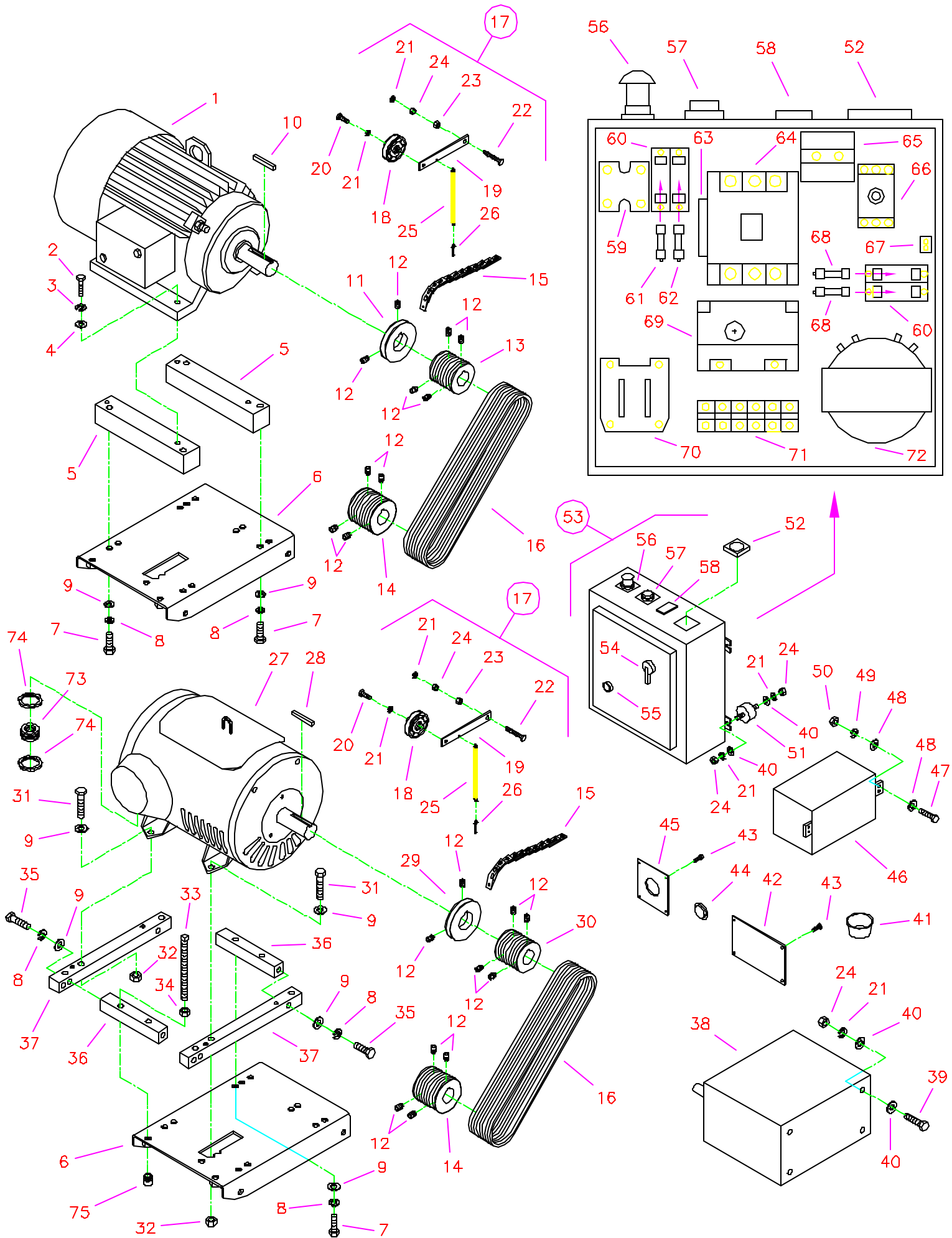

CC6500E Parts List
Drawing VIII
Motor and Starter Group

Diagram Number	Part No.	Qty. Req.	Description	Diagram Number	Part No.	Qty. Req.	Description
1	2600110	1	Motor, 30 Hp Baldor	34	2900112	2	Hex Nut, 5/8"-11
2	2900106	4	Capscrew, Hex Hd., 1/2"-13 x 2"	35	2900527	4	Capscrew, Hex Hd., 5/8"-11 x 2-1/2"
3	2900084	4	Lock Washer, 1/2" Split	36	6012035	2	Motor Connect Spacer
4	2900058	4	Flat Washer, 1/2" SAE	37	6012034	2	Motor Spacer
5	6010171	2	Motor Spacer	38	2700812	1	Soft Start Control Box
6	6010011	1	Motor Base	39	2900005	4	Capscrew, Hex Hd., 3/8"-16 x 1"
7	2900512	4	Capscrew, Hex Hd., 5/8"-11 x 1-1/4"	40	2900014	16	Flat Washer, 3/8" SAE
8	2900113	5	Lock Washer, 5/8" Split	41	2500381	1	Plug, 2-5/8" Hole
9	2900002	9	Flat Washer, 5/8" SAE	42	6010242	1	Dash Cover Panel
10	6010161	1	Bevel End Key, 1/2" Sq. x 4" Long	43	2900021	8	Tapscrew, Pan Hd., #10-24 x 3/8"
11	6012019	1	Accessory Drive Pulley, 1-7/8" Bore	44	2500554	1	Plug, 1-1/2" Hole
12	2900142	14	Setscrew, Soc. Hd., 5/16"-18 x 3/8"	45	6010240	1	Meter Panel (Hour)
13	6010290	1	Sheave, 5.60-8 Groove with 1-7/8" QD	6010241	1	Meter Panel (Tach/Hour)	
			Bushing for 20" Blade Guard	46	2701488	1	Transformer (For 575V Motor)
	6010292	1	Sheave, 5.00-8 Groove with 1-7/8" Taper	2800293	1	Transformer (For 50HZ Motor)	
			Bushing for 26" Blade Guard	47	2900008	4	Capscrew, Hex Hd., 1/4"-20 x 1"
	6010294	1	Sheave, 4.75-8 Groove with 1-7/8" Taper	48	2900009	8	Flat Washer, 1/4" SAE
			Bushing for 30" Blade Guard	49	2900024	4	Lock Washer, 1/4" Split
	6010236	1	Sheave, 4.12-8 Groove x 1-7/8" Bore	50	2900125	4	Hex Nut, 1/4"-20
			for 36" Blade Guard	51	2500678	4	Vibration Isolator, 3/8"-16
14	6010147	1	Sheave, 4.12-8 Groove x 1-3/4" Bore	52	2800203	1	Amp Meter, 30HP 0-100 AC
			for 20" Blade Guard	2800141	1	Amp Meter, 40HP 0-100 AC	
	6010149	1	Sheave, 4.50-8 Groove x 1-3/4" Bore	53	2800215	1	Starter Box Assembly (Includes #54 - #72)
			for 26" Blade Guard	54	2701870	1	Disconnect Handle (Red / Black)
	6012062	1	Sheave, 5.00-8 Groove with 1-3/4" Taper	2701871	1	Handle Shaft Only	
			Bushing for 30" Blade Guard	55	2800245	1	Reset Button
	6012053	1	Sheave, 5.30-8 Groove with 1-3/4" QD	56	6011096	1	Stop Button Assembly
			Bushing for 36" Blade Guard	2800199	1	(Stop Button Body Only)	
15	6010117	1	Link Belt for Sundstrand Transmission	2800201	1	(Red Mushroom Cap)	
	6010063	1	Link Belt for Eaton Transmission	2800200	1	(Contact Block N.C.)	
	2500169	1	(Link Belt Assembly Tool)	57	6011097	1	Start Button Assembly
16	2500188	8	V-Belt, 3VX560	2701390	1	(Start Button Body Only)	
	2500589	2	Banded Belt, 3VX560-4 Strand	2800317	1	(Green Cap)	
17	6010194	1	Idler Assembly (Includes #18 - #26)	2800222	1	(Clear Protective Boot)	
18	2500074	1	Idler Pulley	2701392	1	(Contact Block N.O.)	
19	6048218	1	Idler Arm	58	2800224	1	Battery Charge Amp Meter, 12V-DC
20	2900013	1	Capscrew, Hex Hd., 3/8"-16 x 1-1/4"	59	2701274	1	Rectifier Bridge
21	2900006	14	Lock Washer, 3/8" Split	60	2800299	2	Dual Fuse Holder, 30A-600V
22	2900521	1	Tap Bolt, Hex Hd., 3/8"-16 x 2-1/2"	61	2701066	1	Fuse ATQR 10A (For Control Circuit)
23	2900018	1	Lock Nut, 3/8"-16 Nylon	62	2701307	1	Fuse ATMR 25A (For Battery Charger)
24	2900033	13	Hex Nut, 3/8"-16	63	2800400	1	Auxiliary Contact, N.O. (Siemens)
25	2500195	1	Idler Spring, 3/8" x 7-3/4"	2800235	1	Auxiliary Contact, N.O. (Furnas)	
26	2900055	1	Cotter Pin, 3/16" x 1"	64	2800401	1	Motor Contactor (Siemens)
27	2600185	1	Motor, 40 Hp Lincoln	2800402	1	Coil, 24V-AC (Siemens)	
28	6010161	1	Bevel End Key, 1/2" Sq. x 4" Long	2701084	1	Motor Contactor (Furnas)	
29	6010182	1	Accessory Drive Pulley, 2-1/8" Bore	2701294	1	Coil, 24V-AC (Furnas)	
30	6010291	1	Sheave, 5.60-8 Groove with 2-1/8" QD	65	2800248	1	Current Transformer (For AC Amp Meter)
			Bushing for 20" Blade Guard	66	2701267	1	Disconnect Block 80A
	6010293	1	Sheave, 5.00-8 Groove with 2-1/8" Taper	67	2800315	1	Grounding Lug
			Bushing for 26" Blade Guard	68	2701273	2	Fuse ATQR 4A (For Transformer)
	6010295	1	Sheave, 4.75-8 Groove with 2-1/8" Taper	69	2800403	1	Overload Relay, Range 25-100A (Siemens)
			Bushing for 30" Blade Guard	2701068	1	Overload Relay, Range 30-60A (Furnas)	
	6010237	1	Sheave, 4.12-8 Groove x 2-1/8" Bore	70	2701295	1	Power Relay, 12V-DC
			for 36" Blade Guard	71	6011098	1	Terminal Block Assembly
31	2900137	4	Capscrew, Hex Hd., 5/8"-11 x 3-1/4"	72	2701299	1	Transformer, 500VA
32	2900135	4	Lock Nut, 5/8"-11 Nylon	73	2800279	1	Reducer Bushing
33	2900385	2	Setscrew, Sq. Hd., 5/8"-11 x 8"	74	2800280	2	Lock Nut, 2" Sealing
				75	2900446	2	Swivel Pan Nut, 5/8"-11

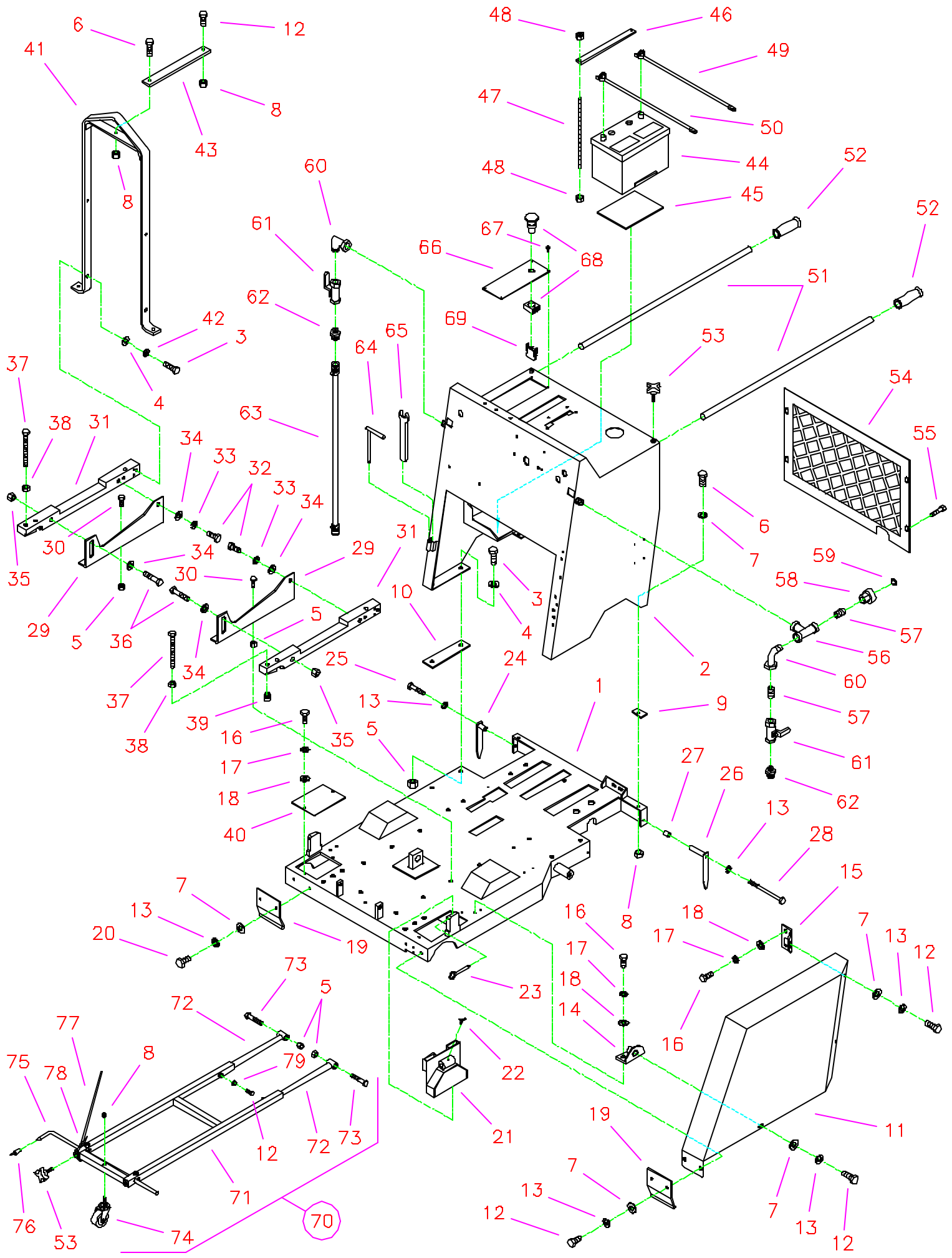

CC6560 Parts List
Drawing IX
Frame Group

Diagram Number	Part No.	Qty. Req.	Description	Diagram Number	Part No.	Qty. Req.	Description
1	6010500	1	Frame Base	41	6047952	1	Frame Lift
2	6010001	1	Frame Upright	42	2900084	2	Lock Washer, 1/2" Split
3	2900139	6	Capscrew, Hex Hd., 1/2"-13 x 1-3/4"	43	6010013	1	Frame Lift Brace
4	2900058	6	Flat Washer, 1/2" SAE	44	2700208	1	Battery, 12 Volt
5	2900026	12	Lock Nut, 1/2"-13 Nylon	45	6010016	1	Battery Pad
6	2900013	3	Capscrew, Hex Hd., 3/8"-16 x 1-1/4"	46	6010017	1	Battery Top Brace
7	2900014	9	Flat Washer, 3/8" SAE	47	6010018	2	Rod, 1/4"-20 x 8-1/2"
8	2900018	5	Lock Nut, 3/8"-16 Nylon	48	2900010	4	Lock Nut, 1/4"-20 Nylon
9	2501337	2	Rubber Frame Mount, Rear	49	2800073	1	Battery Cable, Positive (Red)
10	2501338	2	Rubber Frame Mount, Front	50	2800072	1	Battery Cable, Negative (Black)
11	6010507	1	Belt Guard	51	6010014	2	Handle Bar
12	2900005	8	Capscrew, Hex Hd., 3/8"-16 x 1"	52	2500636	2	Handle Grip
13	2900006	9	Lock Washer, 3/8" Split	53	2900234	4	Hand Lock Knob, 3/8"-16
14	6011110	1	Guard Mounting Tab 90°	54	6010015	1	Rear Cover Screen
15	6014019	2	Guard Mounting Tab 60°	55	2900180	4	Machine Screw, Hex Washer Hd., 1/4"-20 x 1"
16	2900019	8	Capscrew, Hex Hd., 5/16"-18 x 3/4"				
17	2900031	8	Lock Washer, 5/16" Split	56	3200045	1	Pipe Tee, 1/2" NPT
18	2900022	8	Flat Washer, 5/16" SAE	57	3200008	2	Close Nipple, 1/2" NPT
19	6010006	2	Skid Plate for 4-1/2" Dia. Flanges	58	3200022	1	Fitting, 1/2" Female Pipe to 3/4" Female Garden Hose
	6010007	2	Skid Plate for 6-1/4" Dia. Flanges				
20	2900196	2	Capscrew, Hex Hd., 3/8"-16 x 3/4"	59	3200025	1	Filter Hose Washer
21	6011046	1	Shaft/Flange Guard, Narrow	60	3200013	2	Street Elbow, 1/2" NPT
	6011187	1	Shaft/Flange Guard, Wide	61	3200027	2	Water Valve
22	2900307	1	Wing Screw, M6 x 16mm	62	3200155	2	Fitting, 1/2" Male Pipe to 3/4" Male Garden Hose
23	2900156	1	Lock Pin				
24	6010022	1	Rear Pointer, Right Side	63	6010021	1	Hose Assembly, 42" Long
25	2900047	1	Capscrew, Hex Hd., 3/8"-16 x 1-3/4"	64	2900154	1	Bladeshift Lock-Pin
26	6010514	1	Rear Pointer, Left Side	65	2500211	1	Bladeshift Wrench, 15/16"
27	6010515	1	Spacer, 7/8" Long	66	6010019	1	Hydraulic Pump Cover Plate
28	2900375	1	Capscrew, Hex Hd., 3/8"-16 x 4-1/2"	67	2900021	4	Tapscrew, Pan Hd., #10-24 x 3/8"
29	6010501	2	Engine Mount	68	2800213	1	Emergency Stop Button
30	2900025	6	Capscrew, Hex Hd., 1/2"-13 x 1-1/4"	69	2800229	1	Contact Block N.C.
31	6013008	2	Engine Support Leg	70	6011200	1	Front Pointer Assembly
32	2900147	2	Capscrew, Hex Hd., 5/8"-11 x 1-3/4"	71	6011201	1	Front Pointer Frame
33	2900113	2	Lock Washer, 5/8" Split	72	6011152	2	Front Pointer Arm
34	2900002	4	Flat Washer, 5/8" SAE	73	2900105	2	Capscrew, Hex Hd., 1/2"-13 x 2-3/4"
35	2900135	2	Lock Nut, 5/8"-11 Nylon	74	2501199	1	Caster, Threaded Stem
36	2900195	2	Capscrew, Hex Hd., 5/8"-11 x 3"	75	6010009	1	Front Pointer Rod
37	2900104	2	Tap Bolt, Hex Hd., 5/8"-11 x 6"	76	2500740	1	Pointer Cap
38	2900112	2	Hex Nut, 5/8"-11	77	6010010	1	Pointer Cable
39	2900446	1	Swivel Pad Nut, 5/8"-11	78	3200221	3	Cable Clamp
40	6014008	1	Sheave Cover Plate	79	2900033	2	Hex Nut, 3/8"-16

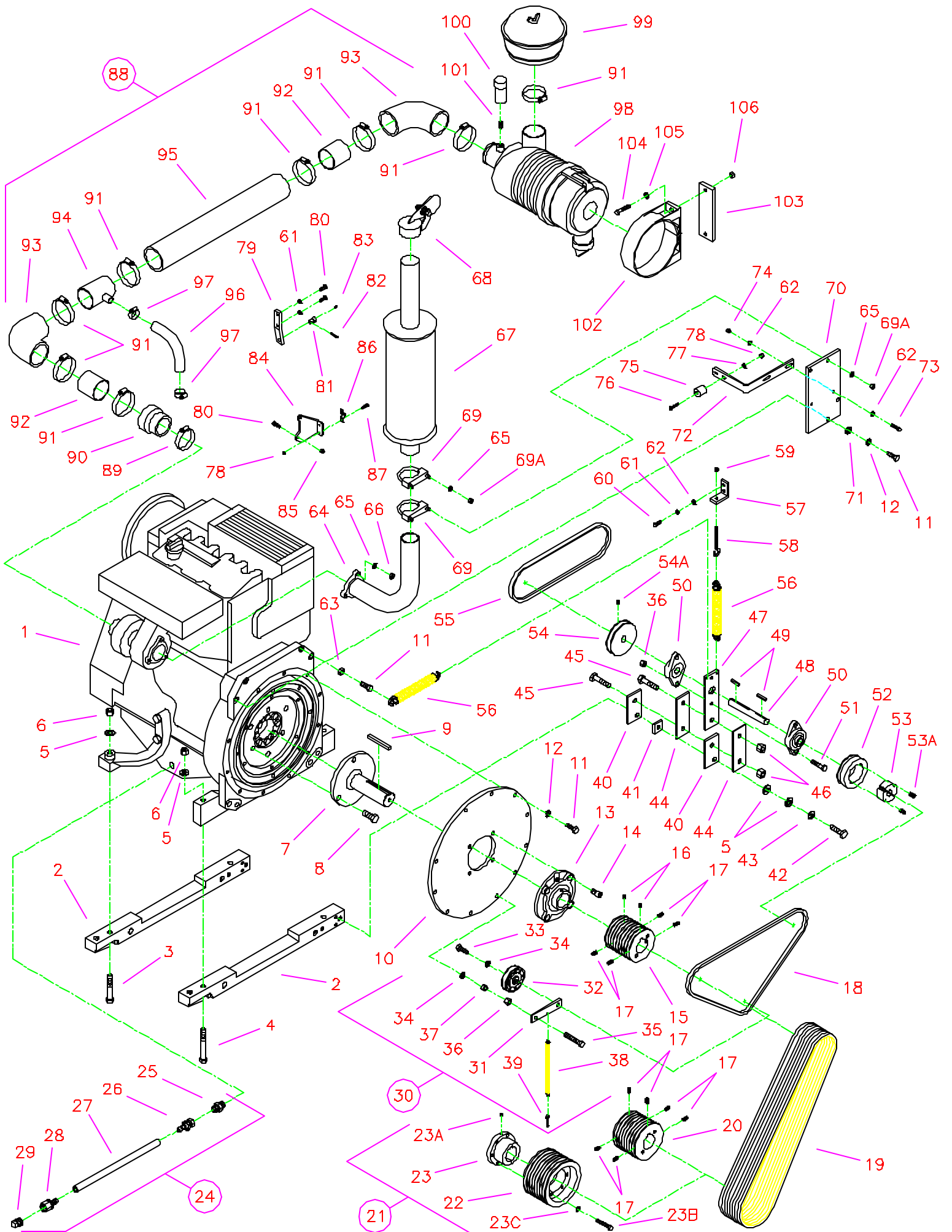

CC6560 Parts List
Drawing X
Engine Group

Diagram Number	Part No.	Qty. Req.	Description	Diagram Number	Part No.	Qty. Req.	Description
1	2600257	1	Engine, Deutz Diesel Model BF3L1011F	49	6048229	2	Key, 3/16" Sq. x 1-1/4
2	6013008	2	Engine Support Leg	50	2500202	2	Flange Block Bearing, 3/4"
3	2900346	2	Capscrew, Hex Hd., M12 x 80mm	51	2900047	2	Capscrew, Hex Hd., 3/8"-16 x 1-3/4"
4	2900347	2	Capscrew, Hex Hd., M12 x 100mm	52	2501325	1	Sheave, 3V-3.65-1 Groove
5	2900058	6	Flat Washer, 1/2" SAE	53	2501191	1	Taper Bushing, 3/4" with Setscrews
6	2900327	4	Lock Nut, M12 Nylon	53A	REF	2	Setscrew, Soc. Hd., 3/8"-16 x 5/8"
7	6012036	1	PTO Shaft	54	2500455	1	Pulley, 4" Single Groove with Setscrew
8	2900349	3	Capscrew, Hex Hd., M14 x 35mm	54A	2900142	1	Setscrew, Soc. Hd., 5/16"-18 x 3/8"
9	4600131	1	Key, 3/8 Sq. x 3"	55	2501290	1	V-Belt, 4L-290 for Sundstrand Transmission
10	6012037	1	Inner Ring Support		2501217	1	V-Belt, 4L-380 for Eaton Transmission
11	2900223	13	Capscrew, Hex Hd., M10 x 30mm	56	2500987	1	Spring, 1" Dia. x 8" Long
12	2900321	12	Lock Washer, M10 Split	57	6011160	1	Spring Tensioning Bracket (Sundstrand)
13	6010509	1	Flange Cartridge Bearing, 1-3/4"	58	2900438	1	Eye Bolt, 1/4"-20 x 3" (Sundstrand)
14	2900460	4	Capscrew, Soc. Hd., 7/16"-14 x 3/4"	59	2900125	1	Hex Nut, 1/4"-20
15	6010502	1	Sheave, 3.65-9 Groove x 1-3/4" Bore for 20" and 26" Blade Guards	60	2900144	2	Capscrew, Hex Hd., 1/4"-20 x 3/4"
	6010503	1	Sheave, 4.00-9 Groove x 1-3/4" Bore for 30" and 36" Blade Guards	61	2900024	4	Lock Washer, 1/4" Split
16	2900142	2	Setscrew, Soc. Hd., 5/16"-18 x 3/8"	62	2900009	6	Flat Washer, 1/4" SAE
17	2900418	10	Setscrew, Soc. Hd., 5/16"-18 x 5/8"	63	2900325	1	Hex Nut, M10
18	2500793	1	V-Belt, 3VX425	64	6013110	1	Exhaust Pipe Weldment
19	2500371	8	V-Belt, 3VX500 for 20" and 26" Blade Guards	65	2900031	7	Lock Washer, 5/16" Split
	2500438	8	V-Belt, 3VX530 for 30" and 36" Blade Guards	66	2900343	3	Hex Nut, M8
	2500437	2	Banded Belt, 3VX500 - 4 Strand for 20" and 26" Blade Guards	67	2700746	1	Muffler
	2501156	2	Banded Belt, 3VX530 - 4 Strand for 30" and 36" Blade Guards	68	2700747	1	Rain Cap
20	6010149	1	Sheave, 4.50-8 Groove x 1-3/4" Bore for 20" and 26" Blade Guards	69	2700748	2	Muffler Clamp with Hex Nuts
21	6010175	1	Sheave, 5.60-8 Groove with 1-3/4" QD Bushing for 30" and 36" Blade Guards (Includes #22 and #23)	69A	2900141	4	Hex Nut, 5/16"-18
22	2500172	1	Sheave Only, 5.60-8 Groove QD Style for 30" and 36" Blade Guards	70	6013102	1	Exhaust Support Plate
23	2500176	1	Bushing Only, 1-3/4" QD with Fasteners	71	2900014	2	Flat Washer, 3/8" SAE
23A	2900056	1	Setscrew, Soc. Hd., 1/4"-20 x 1/4"	72	6010513	1	Pointer Stop
23B	2900289	3	Capscrew, Hex Hd., 5/16"-18 x 2-1/4"	73	2900052	2	Capscrew, Hex Hd., 1/4"-20 x 1-1/4"
23C	2900031	3	Lock Washer, 5/16" Split	74	2900010	2	Lock Nut, 1/4"-20 Nylon
24	6010516	1	Oil Drain Hose Assembly (Includes #25 - #29)	75	2501093	1	Bumper 1"
25	3200180	1	Fitting, M18 x 1.5 Male to 1/2" Male JIC	76	2900172	1	Machine Screw, Round Hd., #10-24 x 1-1/4"
26	3200181	1	Fitting, 1/2" Female JIC to 1/2" Push Lock	77	2900016	1	Flat Washer, #10 USS
27	6010245	1	Oil Drain Hose, 13" Long	78	2900017	3	Lock Nut, #10-24 Nylon
28	3200163	1	Fitting, 1/2" Female Pipe to 1/2" Push Lock	79	6013029	1	Throttle Arm
29	3200160	1	Plug, 1/2" NPT	80	2900310	4	Capscrew, Hex Hd., M6 x 20mm
30	6011076	1	Idler Assembly (Includes #31 - #39)	81	6048212	1	Pivot Pin
31	6011028	1	Idler Arm	82	2900034	1	Cotter Pin, 3/32" x 3/4"
32	2500074	1	Idler Pulley	83	2900059	1	Setscrew, Soc. Hd., #10-32 x 1/4"
33	2900013	1	Capscrew, Hex Hd., 3/8"-16 x 1-1/4"	84	6010523	1	Throttle Bracket
34	2900006	2	Lock Washer, 3/8" Split	85	2900302	2	Lock Nut, M6 Nylon
35	2900520	1	Tap Bolt, Hex Hd., 3/8"-16 x 3"	86	2500940	1	Throttle Cable Clamp
36	2900018	3	Lock Nut, 3/8"-16 Nylon	87	2900015	2	Machine Screw, Hex Hd., #10-24 x 3/4"
37	2900033	1	Hex Nut, 3/8"-16	88	6010517	1	Air Intake Hose Assembly (Includes #89 - #97)
38	2500195	1	Idler Spring, 3/8" x 7-3/4"	89	3200095	1	Hose Clamp #32
39	2900055	1	Cotter Pin, 3/16" x 1"	90	2500229	1	Hose Reducer, 2-1/2" to 2"
40	6011164	2	Jackshaft Brace Plate	91	3200096	8	Hose Clamp #40
41	6011156	1	Jackshaft Spacer	92	6010052	2	Connector Tube, 2-1/2" O.D.
42	2900139	1	Capscrew, Hex Hd., 1/2"-13 x 1-3/4"	93	2500232	2	Hose Elbow, 2-1/2" I.D.
43	2900084	1	Lock Washer, 1/2" Split	94	6010512	1	Connector Tube with Side Port
44	6011155	2	Jackshaft Pivot Plate	95	6010525	1	Air Cleaner Hose, 2-1/2" I.D. x 22" Long
45	2900192	2	Capscrew, Hex Hd., 1/2"-13 x 2-1/4"	96	6010518	1	Intake Hose, 3/4" I.D. x 7" Long
46	2900026	2	Lock Nut, 1/2"-13 Nylon	97	3200135	2	Hose Clamp #16
47	6011154	1	Jackshaft Mount Plate	98	2501328	1	Air Cleaner, Complete
48	6013028	1	Idler Jackshaft		2501288	1	(Outer Primary Element)
					2501289	1	(Inner Safety Element)
					2501185	1	(Rubber Dust Ejector Boot)
				99	2500105	1	Pre-Cleaner with Clamp
				100	2500423	1	Restriction Indicator
				101	3200117	1	Close Nipple, 1/8" NPT
				102	2501329	1	Mounting Band
				103	6010519	1	Air Cleaner Spacer
				104	2900538	2	Capscrew, Hex Hd., 5/16"-18 x 1-3/4"
				105	2900022	2	Flat Washer, 5/16" SAE
				106	2900039	2	Lock Nut, 5/16"-18 Nylon

WIRING DIAGRAM FOR NEWER 35HP AND 65HP WISCONSIN ENGINE (AFTER 8-1-2001)

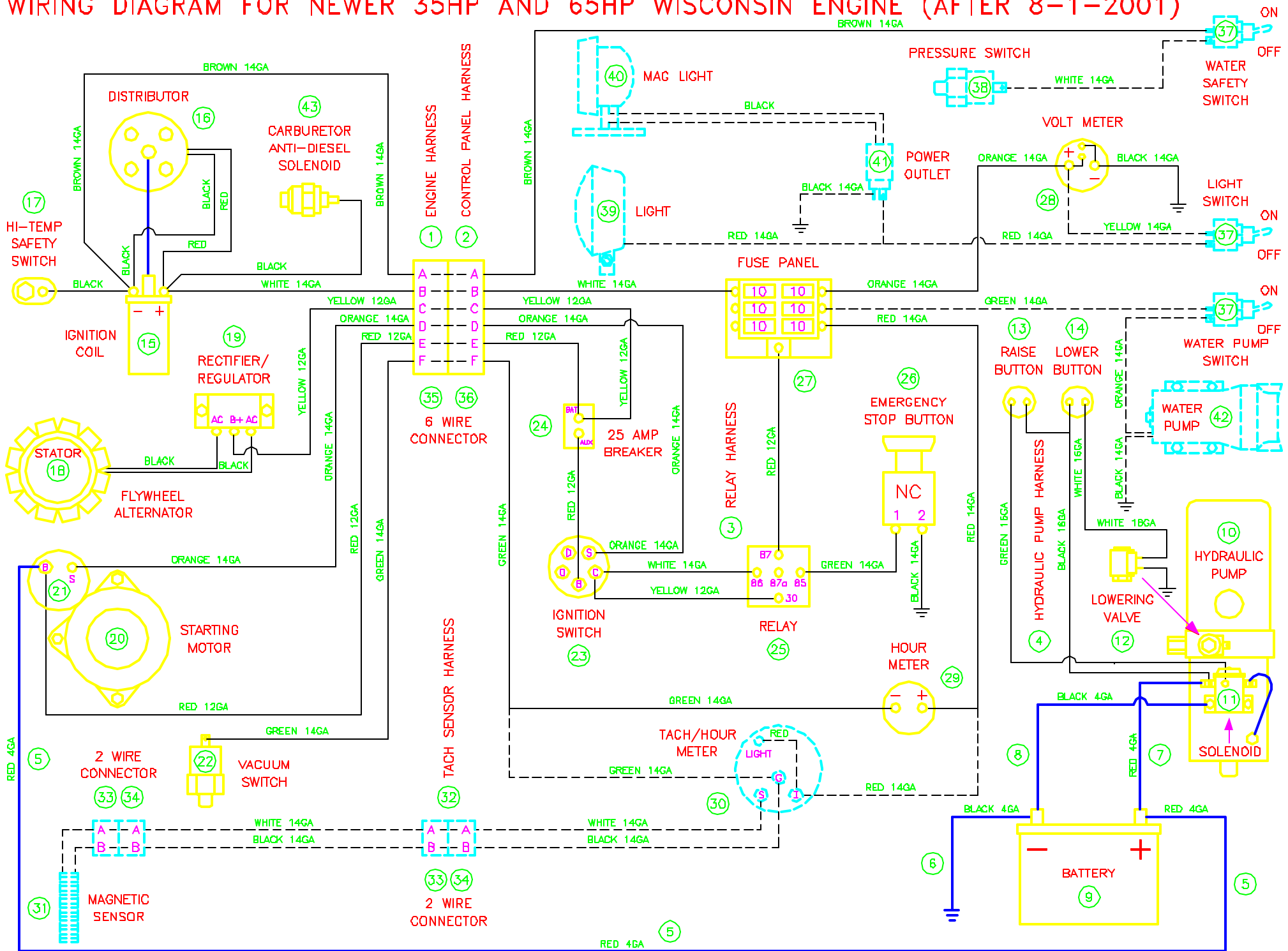

Wiring Diagram
35Hp / 65Hp Wisconsin Engine
(After 9-1-2000)

Diagram Number	Part No.	Qty. Req.	Description	Diagram Number	Part No.	Qty. Req.	Description
1	2800390	1	Engine Harness (Includes #35)	28	2800271	1	Volt Meter
2	2800391	1	Control Panel Harness (Includes #36)	29	2800064	1	Hour Meter
3	2800392	1	Relay Harness	30	2800168	1	Optional Tach/Hour Meter
4	2800393	1	Hydraulic Pump Harness		2800267	1	Light Bulb, Wedge Base
5	2800073	1	Battery Cable, Positive (Red)	31	2800169	1	Optional Magnetic Sensor (Includes #33)
6	2800072	1	Battery Cable, Negative (Black)	32	2800397	1	Optional Tach Sensor Harness (Includes #33 & #34)
7	2800095	1	Solenoid Cable, Positive (Red)				
8	2800182	1	Ground Cable, Negative (Black)	33	2800145	2	Optional Connector, 2 Wire Shroud
9	2700208	1	Battery, 12 Volt		2800114	4	Male Terminal, 14/16 Gage Wire
10	2600070	1	Hydraulic Pump Unit (Includes #11 and #12)		2800174	4	Cable Seal, Gray
11	2700169	1	Solenoid, Motor	34	2800146	2	Optional Connector, 2 Wire Tower
12	2700243	1	Valve Coil		2800115	4	Female Terminal, 14/16 Gage Wire
	2700244	1	Valve Stem		2800174	4	Cable Seal, Gray
13	2800372	1	Pushbutton Switch, Raise	35	2800110	1	Connector, 6 Wire Shroud
14	2800373	1	Pushbutton Switch, Lower		2800114	4	Male Terminal, 14/16 Gage Wire
15	2700205	1	Ignition Coil		2800112	2	Male Terminal, 12 Gage Wire
16	2701474	1	Distributor for 35HP Engine		2800174	4	Cable Seal, Gray
	2701475	1	Distributor for 65HP Engine		2800175	2	Cable Seal, Blue
17	2700299	1	High Temperature Safety Switch	36	2800111	1	Connector, 6 Wire Tower
18	2701634	1	Flywheel Alternator, 30 Amp		2800115	4	Female Terminal, 14/16 Gage Wire
19	2701023	1	Rectifier/Regulator Module		2800113	2	Female Terminal, 12 Gage Wire
20	2700247	1	Starting Motor (Includes #21)		2800174	4	Cable Seal, Gray
21	2700282	1	Solenoid Switch		2800175	2	Cable Seal, Blue
22	2800386	1	Vacuum Switch	37	2800062	3	Optional Toggle Switch
23	2500220	1	Ignition Switch		2800063	3	Switch Boot
24	2800387	1	Circuit Breaker, 25 Amp	38	2800060	1	Optional Water Pressure Safety Switch
	2800364	1	Circuit Breaker Boot, Red	39	2500194	1	Optional Spot Light, 12 Volt
25	2800144	1	Relay	40	2501087	1	Optional Magnetic Base Light, 12 Volt
	2800263	1	Relay Connector	41	2800374	1	Optional Power Outlet, 12 Volt
	2800264	4	Wire Terminal, 1/4" Push-on		2800375	1	Outlet Cap
26	2800213	1	Emergency Stop Button	42	2600200	1	Optional Water Pump, Diaphragm
	2800229	1	Contact Block N.C.	43	2701030	1	Anti-Diesel Solenoid Valve for 65HP Engine Only
27	2800388	1	Fuse Panel, 6 Circuit				
	2800389	6	Fuse, 10 Amp Red ATO/ATC				

WIRING DIAGRAM FOR OLDER 37HP & 65HP WISCONSIN ENGINE (PRIOR TO 9-1-2000)

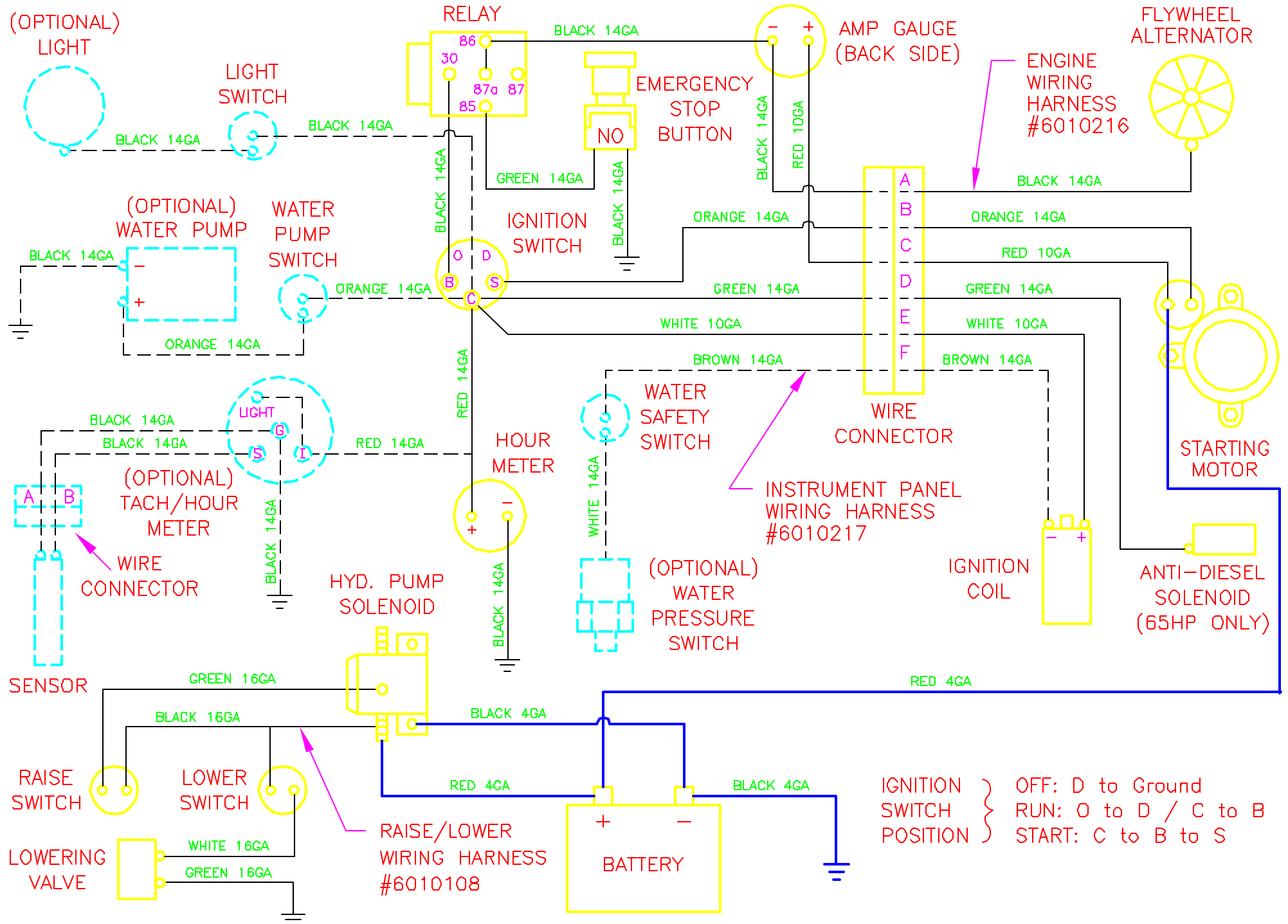

WIRING DIAGRAM FOR ELECTRIC SAW

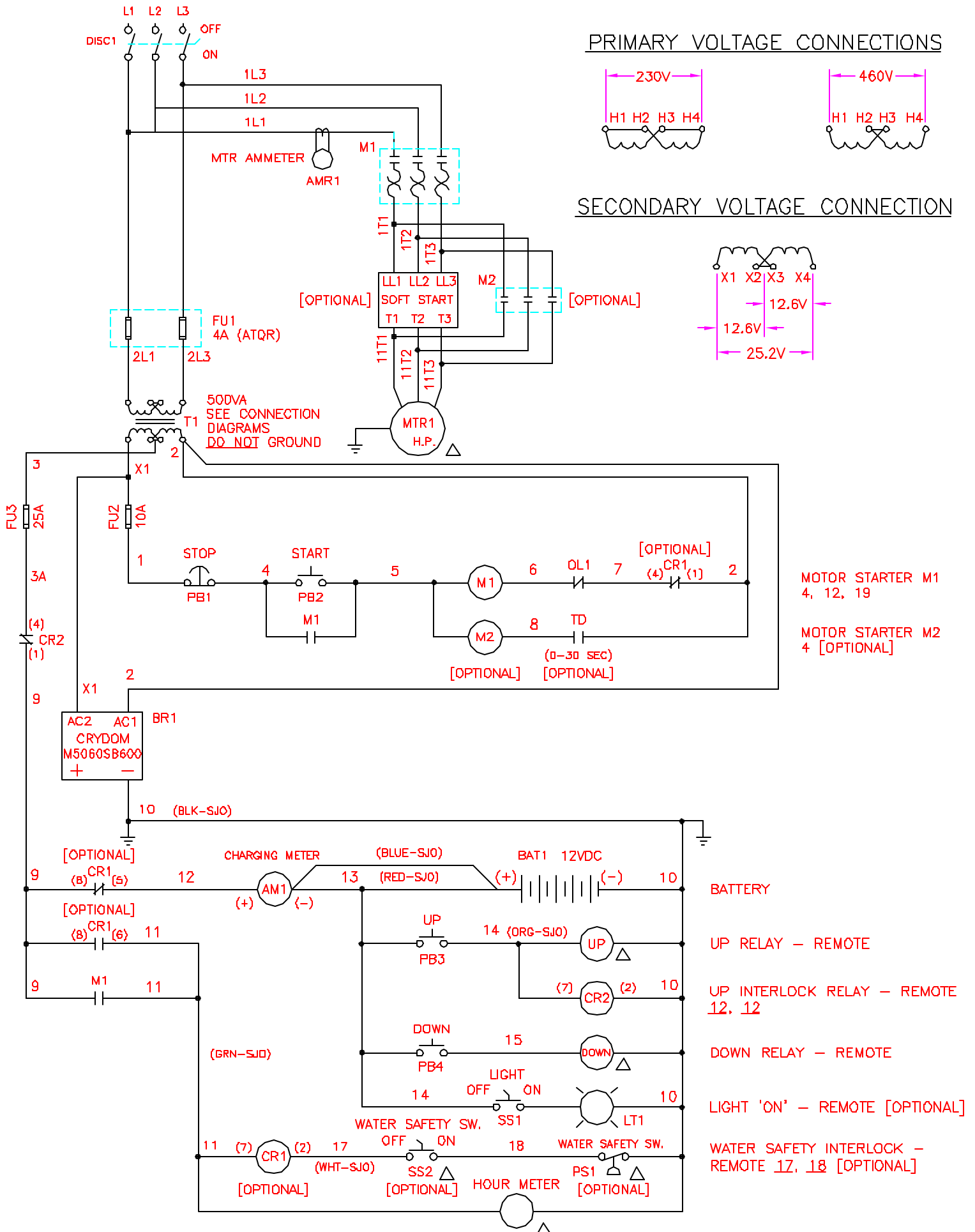

WIRING DIAGRAM FOR NEWER DEUTZ ENGINE (AFTER 9-1-2000)

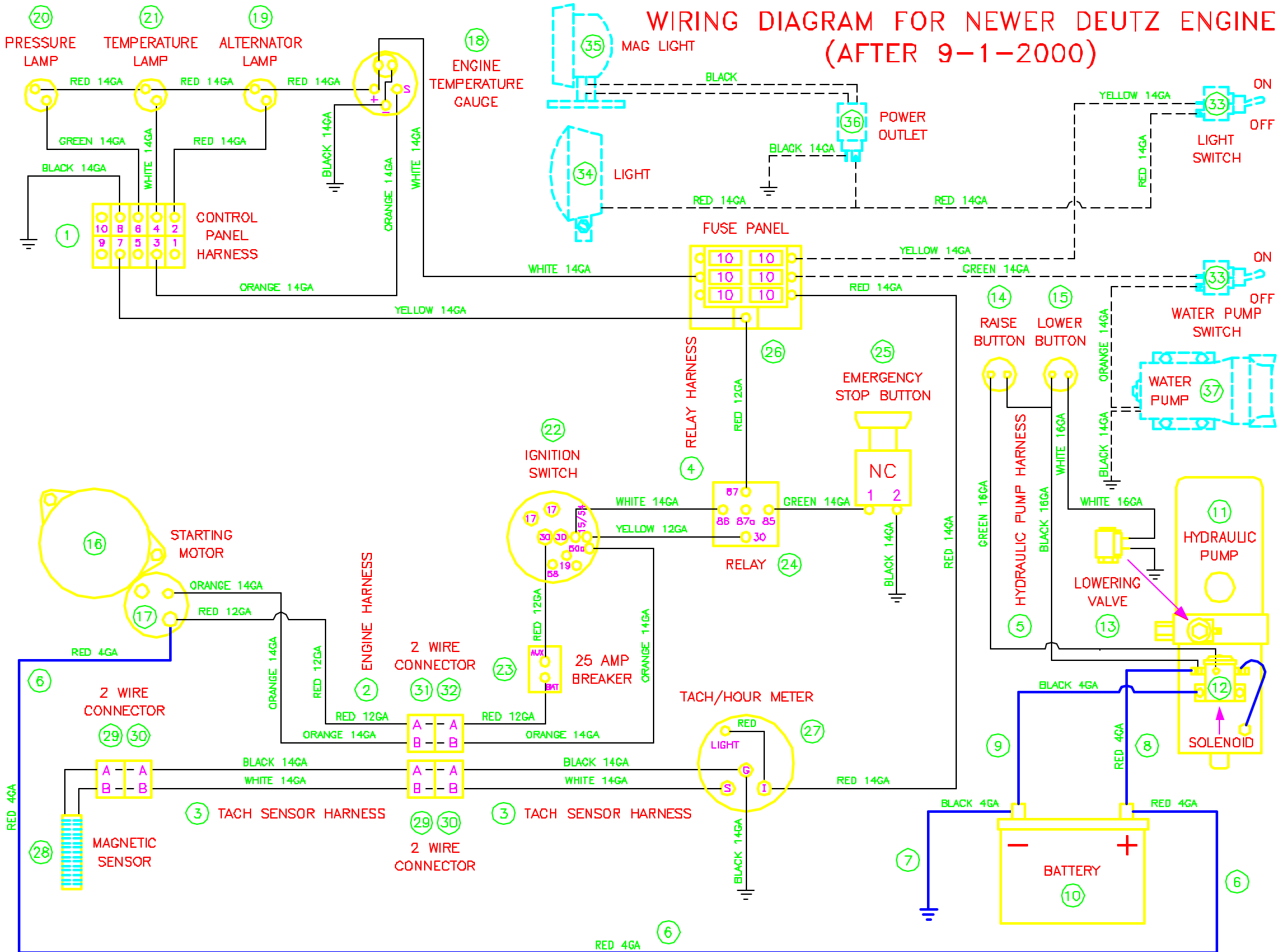

**Wiring Diagram
Deutz Diesel
(After 9-1-2000)**

Diagram Number	Part No.	Qty. Req.	Description	Diagram Number	Part No.	Qty. Req.	Description
1	2800396	1	Control Panel Harness	25	2800213	1	Emergency Stop Button
2	2800429	1	Engine Harness (Includes #31 & #32)		2800229	1	Contact Block N.C.
3	2800397	1	Tach Sensor Harness (Includes #29 & #30)	26	2800388	1	Fuse Panel, 6 Circuit
4	2800392	1	Relay Harness		2800389	6	Fuse, 10 Amp Red ATO/ATC
5	2800393	1	Hydraulic Pump Harness	27	2800168	1	Tach/Hour Meter
6	2800073	1	Battery Cable, Positive (Red)		2800267	1	Light Bulb, Wedge Base
7	2800072	1	Battery Cable, Negative (Black)	28	2800169	1	Magnetic Sensor (Includes #29)
8	2800095	1	Solenoid Cable, Positive (Red)	29	2800145	2	Connector, 2 Wire Shroud
9	2800182	1	Ground Cable, Negative (Black)		2800114	4	Male Terminal, 14/16 Gage Wire
10	2700208	1	Battery, 12 Volt		2800174	4	Cable Seal, Gray
11	2600070	1	Hydraulic Pump Unit (Includes #12 and #13)	30	2800146	2	Connector, 2 Wire Tower
12	2700169	1	Solenoid, Motor		2800115	4	Female Terminal, 14/16 Gage Wire
13	2700243	1	Valve Coil		2800174	4	Cable Seal, Gray
	2700244	1	Valve Stem	31	2800145	1	Connector, 2 Wire Shroud
14	2800372	1	Pushbutton Switch, Raise		2800114	1	Male Terminal, 14/16 Gage Wire
15	2800373	1	Pushbutton Switch, Lower		2800112	1	Male Terminal, 12 Gage Wire
16	2701821	1	Starting Motor (Includes #17)		2800174	1	Cable Seal, Gray
17	2701823	1	Solenoid Switch		2800175	1	Cable Seal, Blue
18	2700784	1	Engine Temperature Gauge	32	2800146	1	Connector, 2 Wire Tower
19	2700785	1	Alternator Light (Orange)		2800115	1	Female Terminal, 14/16 Gage Wire
	2700923	1	(Bulb Only)		2800113	1	Female Terminal, 12 Gage Wire
20	2700786	1	Oil Pressure Light (Green)		2800174	1	Cable Seal, Gray
	2700923	1	(Bulb Only)		2800175	1	Cable Seal, Blue
21	2700787	1	Oil Temperature Light (Red)	33	2800062	2	Optional Toggle Switch
	2700923	1	(Bulb Only)		2800063	2	Switch Boot
22	2700783	1	Ignition Switch with Key	34	2500194	1	Optional Spot Light, 12 Volt
	2701261	1	(Ignition Key Only)	35	2501087	1	Optional Magnetic Base Light, 12 Volt
23	2800387	1	Circuit Breaker, 25 Amp	36	2800374	1	Optional Power Outlet, 12 Volt
	2800364	1	Circuit Breaker Boot, Red		2800375	1	Outlet Cap
24	2800144	1	Relay	37	2600200	1	Optional Water Pump, Diaphragm
	2800263	1	Relay Connector				
	2800264	4	Wire Terminal, 1/4" Push-on				

GOVERNOR SETTING

Wisconsin Engine Model V-465D 65 HP

GOVERNOR ADJUSTMENT (Fig. 16, Fig. 17) —The governor rod connection to the carburetor must be very carefully adjusted for length, otherwise the governor will not function properly and cause the engine to surge badly. With the engine at rest, the governor spring will keep the flyweights *in*, and the control rod must be of such length as to hold the carburetor throttle wide open at that point.

With the *control rod* disconnected from the *governor lever*, as illustrated in Fig. 16, push the rod toward the carburetor as far as it will go. This will put the *carburetor throttle lever* in a wide open position. The governor lever should then be moved as far as possible in the same direction. Holding both parts in the above position, the rod should be screwed in or out of the *swivel block* on the carburetor, until the bent end of the rod will register with *hole* in lever, then screw rod in one more turn. The extra turn will shorten the linkage slightly and will enable the carburetor throttle lever to bounce back from the stop pin rather than jam against the pin, when a load is suddenly applied to an idling engine. This will eliminate excessive wear on the threads in the carburetor throttle swivel block.

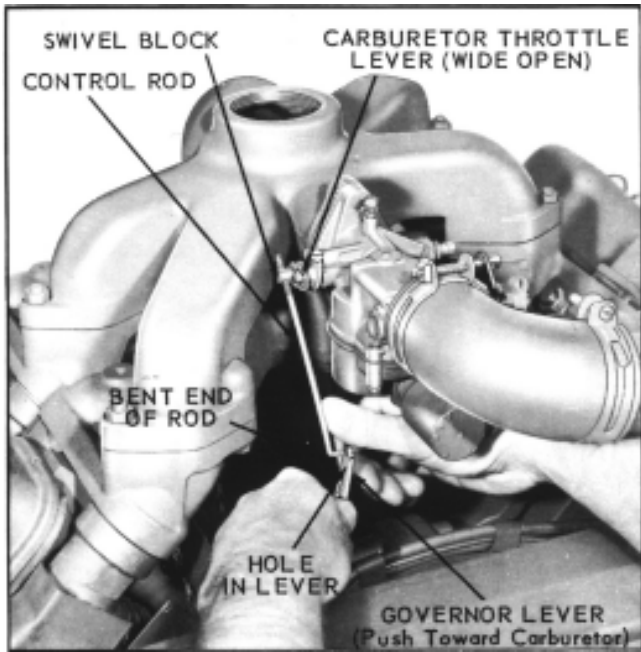

FIG. 16

Caution: Never run engine with governor disconnected.

GOVERNOR LEVER — The governor lever, Fig. 17, is furnished with 12 holes for attaching the governor spring. It is very important that the spring is hooked into the proper hole to suit the speed at which the engine is to be operated. The Governor Lever Chart shows the full load and no load speeds of the engine and the hole corresponding thereto, for either a fixed speed, a variable speed or two speed (over-center idle control) governor. Note that the *full load* speed is less than the *no load* speed and this must be taken into consideration when readjusting the governor. As an example; if the engine is to be operated at 2000 revolutions per minute under load, the spring should be hooked into the 6th hole in the governor lever and the spring tension adjusted, by means of the adjusting screw, to run 2200 R.P.M. under no load. The speed at full load will then be approximately 2000 revolutions per minute.

A tachometer or revolution counter should be used against the crankshaft to check speed while adjusting the governor spring tension. Tightening the adjusting screw locknut will give higher speeds, while loosening the locknut will lower the spring tension and reduce the R.P.M.

FULL LOAD R.P.M.	NO LOAD R.P.M.	HOLE NO.	GOVERNOR LEVER	HOLE NO.
1500	1685	3		12
1600	1825	4		11
1700	1855	4		10
1800	2000	5		9
1900	2055	5		8
2000	2200	6		7
2100	2230	6		6
2200	2375	7		5
2300	2440	7		4
2400	2545	8		3
2500	2695	9		2
2600	2745	9		1
2700	2810	9		
2800	2935	10		
2900	3065	11		
3000	3175	12		

TELEDYNE WISCONSIN MOTOR

FIG. 17

MILWAUKEE, WISCONSIN 53219

Blade / Engine Speed (RPM) Chart Model CC6565 Concrete Saw

WARNING: Do not exceed Bladeshaft speed (RPM) shown for each blade size. Excessive Blade Speed could result in blade breakage and serious personal injury.

Blade Size	Max Depth of Cut
14"	4-5/8"
20"	7-5/8"
26"	10-5/8"
30"	11-3/4"
36"	14-3/4"
42" *	16-3/4"
48" *	19-3/4"

Blade Size	Bladeshaft		Engine		Governor Setting
	No Load RPM	Sheave Size	No Load RPM	Sheave Size	
14"	2,900	4.12"	3,000	4.00"	10
20"	2,450	4.50"	2,750	4.00"	9
26"	1,950	4.50"	2,200	4.00"	6
30"	1,575	5.60"	2,200	4.00"	6
36"	1,425	5.60"	2,000	4.00"	5
42" *	1,050	7.60"	2,200	3.65"	6
48" *	960	7.60"	2,000	3.65"	5

CAUTION: When changing blade size, use chart shown below for selecting items that must be changed.

Model CC6565	14"	20"	26"	30"	36"	42" *	48" *
Blade Guard Assembly	6010070	6010072	6010074	6010076	6010078	6010143	6010145
Bladeshaft Sheave, 1-3/4" Bore (Sheave Size)	6010155 (4.12")	6010157 (4.50")	6010157 (4.50")	6010113 (5.60")	6010113 (5.60")	6010283 (7.60")	6010283 (7.60")
Inner Flanges (Flange Size)	6010036 (4.50")	6010036 (4.50")	6010036 (4.50")	6010038 (6.00")	6010038 (6.00")	6013017 (8.00")	6013017 (8.00")
Outer Flange (Flange Size)	6010037 (4.50")	6010037 (4.50")	6010037 (4.50")	6010039 (6.00")	6010039 (6.00")	6013018 (8.00")	6013018 (8.00")
Skid Plate	6010006	6010006	6010006	6010007	6010007	6013038	6013038
Engine Base Mounting Holes	Rear Set	Rear Set	Rear Set	Front Set	Front Set	Front Set	Front Set

* Note: Items shown for 42" and 48" are for reference only. Use complete conversion kit #6010274 for 42" and #6010275 for 48" when converting from 14" through 36".

Options Available:

- #6011032 Water Pump Kit - includes 12 Volt Pump, Toggle Switch, Hose and Fittings.
- #6010112 Spotlight Kit - includes 12 Volt Light, Mounting Bar and Bracket, Lock Knobs, Toggle Switch.
- #6010181 Oil Cooler Kit - includes Cooler, Oil Filter, Adapters, Hose and Fittings.
- #2700143 Vertical Muffler Kit - includes Muffler, Clamp and Rain Cap.
- #6010179 Free Wheeling Clutch Kit - includes Clutch Sprocket and Hub, Engage/Disengage Lever, Linkage.
- #6047932 Water Safety Switch Kit - includes Safety Shut-off Switch and Toggle Switch.
- #6010185 Side Plunge Kit - includes Bladeshaft, Flanges, and 20" Extra Wide Blade Guard.
- #6010110 Outboard Bearing Kit - includes Flange Bearing, Support Plates, Spacer Tubes, Shaft Extension.
- #6010226 Bladeshaft Tachometer Kit - includes Tach/Hour Meter, Magnetic Sensor, Gear, Wiring Harness.
- #6010227 Lowering Speed Metering Valve Kit - includes Metering Valve, Check Valve, Hydraulic Hose & Fittings.
- #6011170 Magnetic Spotlight Kit - includes 12 Volt Light with Magnetic Base, Power Outlet, Toggle Switch.
- #6010299/300 Catalytic Converter Kit - includes Catalytic Muffler, Air Pump, Belt, Hoses, Pulley, Hardware.
- #6010249 Extended Bladeshaft Kit (3/4" to 1-1/2") - includes 4-1/2" Extended Outer Flange, Bolt, 20" Extra Wide Blade Guard.
- #6010229 Extended Bladeshaft Kit (1-1/2" to 2-1/4") - includes Shaft Extension, 4-1/2" Outer Flange, Nut, 20" Extra Wide Blade Guard.
- #6010274 42" Blade Capacity Conversion Kit - includes Frame Base Extension, Bladeshaft Assembly, Belts & Pulleys, Belt & Blade Guards, Weights.
- #6010275 48" Blade Capacity Conversion Kit - includes Frame Base Extension, Bladeshaft Assembly, Belts & Pulleys, Belt & Blade Guards, Weights.

Blade / Engine Speed (RPM) Chart Model CC6560 Concrete Saw

WARNING: Do not exceed Bladeshaft speed (RPM) shown for each blade size. Excessive Blade Speed could result in blade breakage and serious personal injury.

Blade Size	Max Depth of Cut
20"	7-5/8"
26"	10-5/8"
30"	11-3/4"
36"	14-3/4"

Blade Size	Bladeshaft		Engine	
	No Load RPM	Sheave Size	No Load RPM	Sheave Size
20"	2,425	4.50"	3,000	3.65"
26"	2,025	4.50"	2,500	3.65"
30"	1,650	5.60"	2,300	4.00"
36"	1,425	5.60"	2,000	4.00"

CAUTION: When changing blade size, use chart shown below for selecting items that must be changed.

Model CC6560	20"	26"	30"	36"
Blade Guard Assembly	6010072	6010074	6010076	6010078
Engine Sheave, 1-3/4" Bore (Sheave Size)	6010502 (3.65")	6010502 (3.65")	6010503 (4.00")	6010503 (4.00")
Bladeshaft Sheave, 1-3/4" Bore (Sheave Size)	6010149 (4.50")	6010149 (4.50")	6010175 (5.60")	6010175 (5.60")
Engine Belts (8) (Belt Size)	2500371 (3VX500)	2500371 (3VX500)	2500438 (3VX530)	2500438 (3VX530)
Inner Flanges (Flange Size)	6010036 (4.50")	6010036 (4.50")	6010038 (6.00")	6010038 (6.00")
Outer Flange (Flange Size)	6010037 (4.50")	6010037 (4.50")	6010039 (6.00")	6010039 (6.00")
Skid Plate	6010006	6010006	6010007	6010007

Options Available:

#6011032 Water Pump Kit - includes 12 Volt Pump, Toggle Switch, Hose and Fittings.

#6010112 Spotlight Kit - includes 12 Volt Light, Mounting Bar and Bracket, Lock Knobs, Toggle Switch.

#6010522 Water Safety Switch Kit – includes Safety Shut-off Switch, Relay, and Toggle Switch.

#6010179 Free Wheeling Clutch Kit – includes Clutch Sprocket and Hub, Engage/Disengage Lever, Linkage.

#6010227 Lowering Speed Metering Valve Kit - includes Metering Valve, Check Valve, Hydraulic Hose & Fittings.

#6011170 Magnetic Spotlight Kit – includes 12 Volt Light with Magnetic Base, Power Outlet, Toggle Switch.

#6010249 Extended Bladeshaft Kit (3/4" to 1-1/2") – includes 4-1/2" Extended Outer Flange, Bolt, 20" Extra Wide Blade Guard.

#6010229 Extended Bladeshaft Kit (1-1/2" to 2-1/4") – includes Shaft Extension, 4-1/2" Outer Flange, Nut, 20" Extra Wide Blade Guard.

#2501157 Catalytic Converter Kit – includes Catalytic Muffler.

Blade / Engine Speed (RPM) Chart Model CC6530E and CC6540E Concrete Saw

WARNING: Do not exceed Bladeshift speed (RPM) shown for each blade size. Excessive Blade Speed could result in blade breakage and serious personal injury.

Blade Size	Max Depth of Cut
20"	7-5/8"
26"	10-5/8"
30"	11-3/4"
36"	14-3/4"
42" *	16-3/4"
48" *	19-3/4"

Blade Size	Bladeshift		Motor	
	No Load RPM	Sheave Size	No Load RPM	Sheave Size
20"	2,450	4.12"	1,800	5.60"
26"	2,000	4.50"	1,800	5.00"
30"	1,700	5.00"	1,800	4.75"
36"	1,400	5.30"	1,800	4.12"
42" *	1,075	6.90"	1,800	4.12"
48" *	1,075	6.90"	1,800	4.12"

CAUTION: When changing blade size, use chart shown below for selecting items that must be changed.

Model CC6530E / CC6540E	20"	26"	30"	36"	42" *	48" *
Blade Guard Assembly	6010072	6010074	6010076	6010078	6010143	6010145
30 HP Motor Sheave, 1-7/8" Bore (Sheave Size)	6010290 (5.60")	6010292 (5.00")	6010294 (4.75")	6010236 (4.12")	6010236 (4.12")	6010236 (4.12")
40 HP Motor Sheave, 2-1/8" Bore (Sheave Size)	6010291 (5.60)	6010293 (5.00)	6010295 (4.75)	6010237 (4.12)	6010237 (4.12)	6010237 (4.12)
Bladeshift Sheave, 1-3/4" Bore (Sheave Size)	6010147 (4.12)	6010149 (4.50)	6012062 (5.00)	6012053 (5.30)	6010289 (6.90)	6010289 (6.90)
Inner Flanges (Flange Size)	6010036 (4.50")	6010036 (4.50")	6010038 (6.00")	6010038 (6.00")	6013017 (8.00")	6013017 (8.00")
Outer Flange (Flange Size)	6010037 (4.50")	6010037 (4.50")	6010039 (6.00")	6010039 (6.00")	6013018 (8.00")	6013018 (8.00")
Skid Plate	6010006	6010006	6010007	6010007	6013038	6013038

* Note: Items shown for 42" and 48" are for reference only. Use complete conversion kit #6010276 for 42" and #6010277 for 48" when converting from 14" through 36".

Options Available:

- #6011032 Water Pump Kit - includes 12 Volt Pump, Toggle Switch, Hose and Fittings.
- #6010112 Spotlight Kit - includes 12 Volt Light, Mounting Bar and Bracket, Lock Knobs, Toggle Switch.
- #6047932 Water Safety Switch Kit - includes Safety Shut-off Switch and Toggle Switch.
- #6010185 Side Plunge Kit - includes Bladeshift, Flanges, and 20" Extra Wide Blade Guard.
- #6010226 Bladeshift Tachometer Kit - includes Tach/Hour Meter, Magnetic Sensor, Gear, Wiring Harness.
- #6010227 Lowering Speed Metering Valve Kit - includes Metering Valve, Check Valve, Hydraulic Hose & Fittings.
- #6010228 Soft Start Controller Kit - includes Controller Assembly Box and Wiring.
- #6011170 Magnetic Spotlight Kit - includes 12 Volt Light with Magnetic Base, Power Outlet, Toggle Switch.
- #6010249 Extended Bladeshift Kit (3/4" to 1-1/2") - includes 4-1/2" Extended Outer Flange, Bolt, 20" Extra Wide Blade Guard.
- #6010229 Extended Bladeshift Kit (1-1/2" to 2-1/4") - includes Shaft Extension, 4-1/2" Outer Flange, Nut, 20" Extra Wide Blade Guard.
- #6010276 42" Blade Capacity Conversion Kit - includes Frame Base Extension, Bladeshift Assembly, Belts & Pulleys, Belt & Blade Guards, Weights.
- #6010277 48" Blade Capacity Conversion Kit - includes Frame Base Extension, Bladeshift Assembly, Belts & Pulleys, Belt & Blade Guards, Weights.

EQUIPMENT AND PARTS WARRANTY

Diamond Products warrants all equipment manufactured by it against defects in workmanship or materials for a period of one (1) year from the date of shipment to Customer.

The responsibility of Diamond Products under this Warranty is limited to replacement or repair of defective parts at Diamond Products' Elyria, Ohio factory, or at a point designated by it, of such parts as shall appear to us upon inspection at such point, to have been defective in material or workmanship, with expense for transportation and labor borne by Customer.

In no event shall Diamond Products be liable for consequential or incidental damages arising out of the failure of any Product to operate properly.

Integral units such as engines, electric motors, batteries, transmissions, etc., are excluded from this Warranty and are subject to the prime manufacturer's warranty.

THIS WARRANTY IS IN LIEU OF ALL OTHER WARRANTIES, EXPRESSED OR IMPLIED, AND ALL SUCH OTHER WARRANTIES ARE HEREBY DISCLAIMED.



333 Prospect Street, Elyria, Ohio 44035
(440) 323-4616 • (800) 321-5336 • Fax (440) 323-8689
www.diamondproducts.com