

Spare Parts List
Ersatzteilliste
Liste de pièces détachées
Lista de piezas de repuesto

2003-01

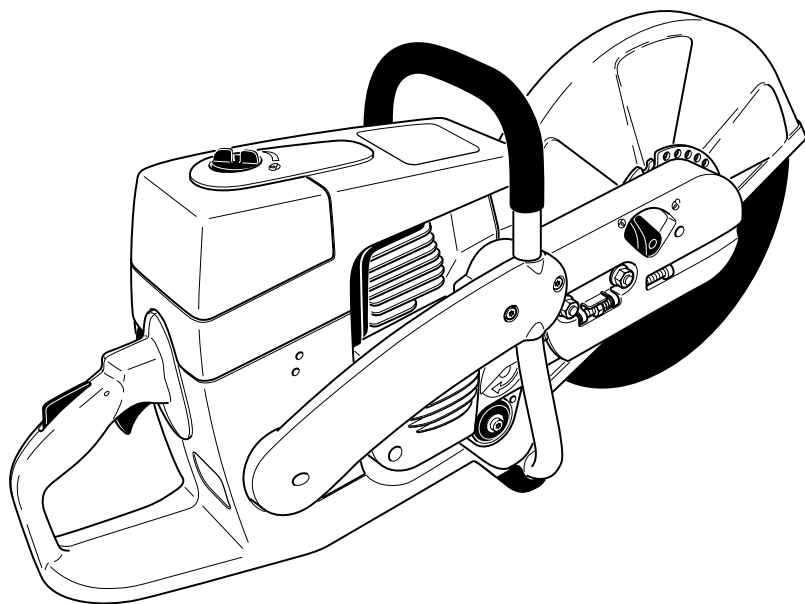

Model SC-7312 (P/N 5800468)
Model SC-7314 (P/N 5800469)



SC-7312
SC-7314

1

Tankeinheit und Handgriffe
Tank and handle grips
Réservoir et poignées
Depósito y mangos

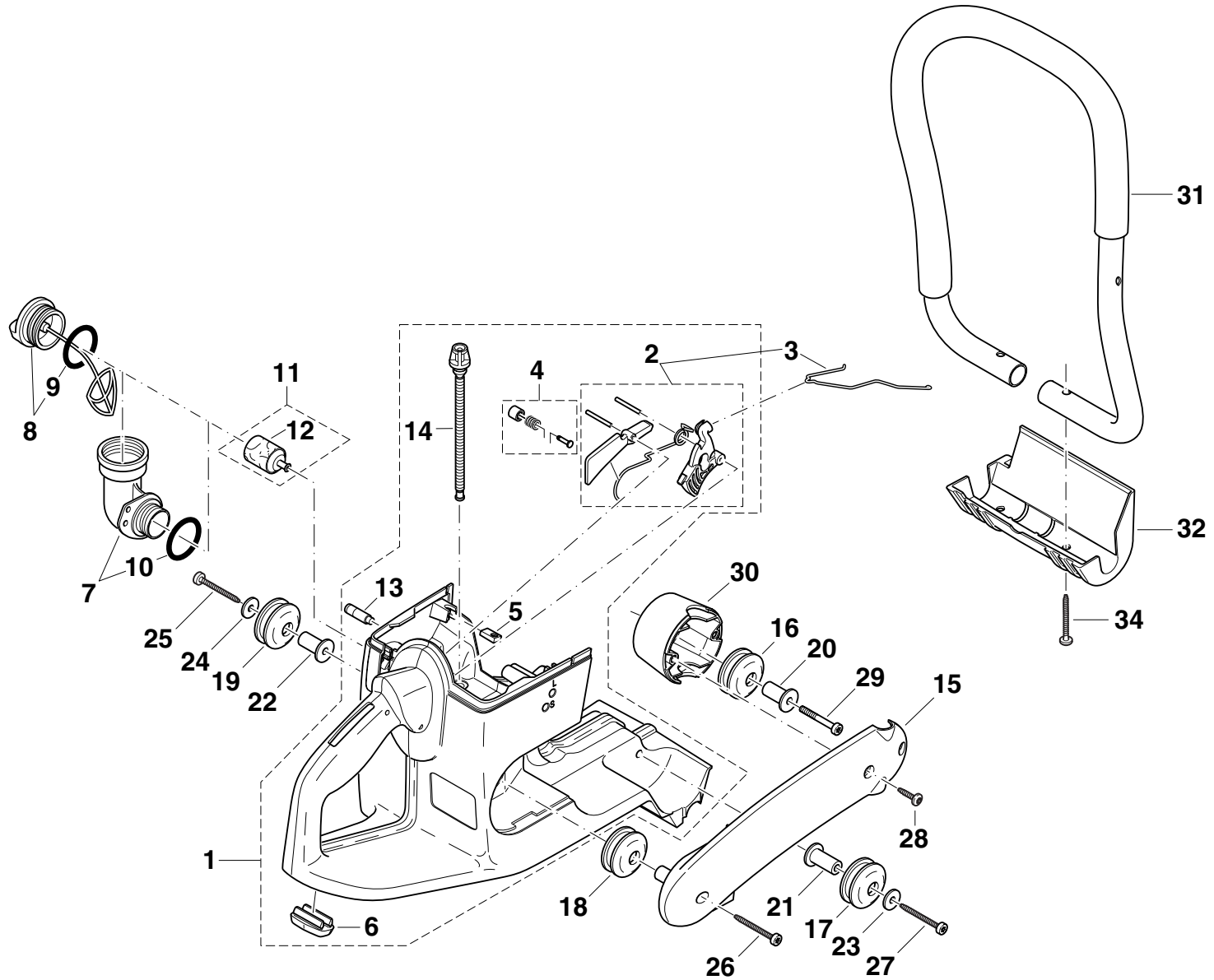

SC 7312, 7314



Seite / Page	Pos.	SC 7312	SC 7314	Speedi Cut Part No.	Hinweise Notes Renseign. Nota	Description	Spezifikation Specification	Bezeichnung	Désignation	Denominación
1	1	1	1	6060038		Tank kpl. mit Mechanik, rot		Tank cpl., red	Réservoir cpl., rouge	Depósito cpl., rojo
1	2	1	1	6060145		Gasmechanik kpl.		Throttle mechanism, cpl.	Mécanique de déclenche. cpl.	Mecanismo acelerador, cpl.
1	3	1	1	6060140		Gasgestänge		Throttle linkage	Tringle d' accélération	Varilla acelerador
1	4	1	1	6060108		Halbgasarrretierung kpl.		Half-throttle lock, cpl.	Dispos. d'arrêt demi-gaz cpl.	Bloqueo medio gas, cpl.
1	5	4	4	6060037		Schraubeinsatz		Screw plug	Embout de vissage	Alojamiento de tornillos
1	6	1	1	6060036		Gummifuß		Rubber foot	Pied, caotchouc	Pie, goma
1	7	1	1	6060137	Acc.	Winkeltankverschluß kpl.		Angular union assy.	Manchon coudé cpl.	Cierre angular cpl.
1	8	1	1	6060138		Tankdeckel kpl., Kraftstoff		Tank cap cpl., fuel	Bouchon réservoir cpl., carb.	Cierre depósito cpl., comb.
1	9	1	1	6060158		O-Ring, rot	ø30x3	O-Ring, red	Bague joint, rouge	Anillo de guarnición, rojo
1	10	1	1	6060158		O-Ring, rot	ø30x3	O-Ring, red	Bague joint, rouge	Anillo de guarnición, rojo
1	11	1	1	6060116		Saugkopf		Suction head	Tête d' aspiration	Cabeza de aspiración
1	12	1	1	6060117		Filz		Felt	Feutre	Filtro
1	13	1	1	6060139		Belüftungsventil kpl.		Air valve cpl.	Soupape d' aeration cpl.	Válvula ventilacion cpl.
1	14	1	1	6060160		Saugschlauch Kraftstoff		Fuel line	Conduite carb.	Tubo comb.
1	15	1	1	6060033		Seitenstrebe, schwarz	Speedi Cut	Bracket, black	Support, noir	Soporte, negro
1	16	1	1	6060122		Schwingungsdämpfer		Rubber buffer	Amortisseur	Amortiguador
1	17	1	1	6060122		Schwingungsdämpfer		Rubber buffer	Amortisseur	Amortiguador
1	18	1	1	6060122		Schwingungsdämpfer		Rubber buffer	Amortisseur	Amortiguador
1	19	1	1	6060122		Schwingungsdämpfer		Rubber buffer	Amortisseur	Amortiguador
1	20	1	1	6060032		Achse für Dämpfer		Axle	Axe	Eje
1	21	1	1	6060032		Achse für Dämpfer		Axle	Axe	Eje
1	22	1	1	6060032		Achse für Dämpfer		Axle	Axe	Eje
1	23	1	1	6060100		Scheibe	ø 5,5	Washer	Rondelle	Arandela
1	24	1	1	6060100		Scheibe	ø 5,5	Washer	Rondelle	Arandela
1	25	1	1	6060094		Schraube	⊕ 5,5x45	Screw	Vis	Tornillo
1	26	1	1	6060094		Schraube	⊕ 5,5x45	Screw	Vis	Tornillo
1	27	1	1	6060094		Schraube	⊕ 5,5x45	Screw	Vis	Tornillo
1	28	2	2	6060093		Schraube	⊕ 5,5x20	Screw	Vis	Tornillo
1	29	1	1	6060089		Schraube	⊕ M5x20x40	Screw	Vis	Tornillo
1	30	1	1	6060034		Aufnahmetopf für Dämpfer, schwarz		Pot, black	Capuchon, noir	Pote, negro
1	31	1	1	6060080		Rundumgriff kpl.		Wrap around handle	Poignée circulaire	Mango circular
1	32	1	1	6060035		Standfuß		Foot	Pied	Pie
1	34	2	2	6060094		Schraube	⊕ 5,5x45	Screw	Vis	Tornillo

SC-7312
SC-7314

2

Abdeckhaube, Luftfilter
Hood, air filter
Capot, filtre à air
Cubierta, filtro de aire

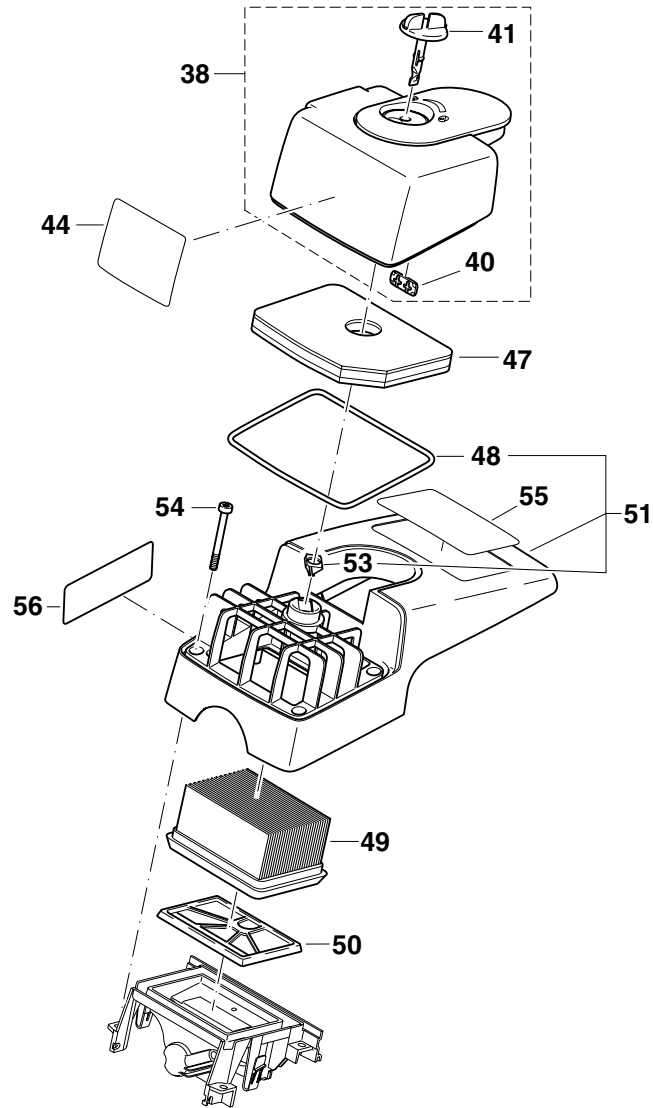

SC 7312, 7314



Seite / Page	Pos.	SC 7312	SC 7314	Speedi Cut Part No.	Hinweise Notes Renseign. Nota	Description	Spezifikation Specification	Bezeichnung	Désignation	Denominación
2	38	1	1	6060041		Filterdeckel kpl., rot		Filter cover assy., red	Capot filtre cpl., rouge	Cubierta p. filtre cpl., rojo
2	40	1	1	6060040		Einsatz Sommer/Winter, schw.		Insert, black	Pièce d'insertion, noir	Pieza de cierre, negro
2	41	1	1	6060141		Bajonettverschluß		Bayonet fixing	Fermeture à baïonnette	Cierre de bayoneta
2	44	1		6060210		Sicherheitsaufkleber	ø300/20,0mm; ø12"/.787"	Safety label	Plaque	Calcomania
2	44		1	6060133		Sicherheitsaufkleber	ø350/20,0mm; ø14"/.787"	Safety label	Plaque	Calcomania
2	47	1	1	6060065		Vorfilter		Prefilter	Prefiltre	Primer filtro
2	48	1	1	6060039		Dichtring		Packing ring	Bague-joint	Anillo de guarnición
2	49	1	1	6060064		Luftfiltereinsatz		Air filter	Filtre à air	Filtro de aire
2	50	1	1	6060164		Innenfilter		Inner filter	Filtre intérieur	Filtro de aire interior
2	51	1	1	6060142		Abdeckhaube kpl., schwarz		Hood cpl., black	Capot protection cpl., noir	Tapa protectora cpl., negro
2	53	1	1	6060249		Verschluß-Unterteil		Bayonet lock	Clip de baïonnette	Alojamiento de la bayoneta
2	54	4	4	6060090		Schraube	✳ M5x55	Screw	Vis	Tornillo
2	55	1		6060132		Schild	SC 7312	Label	Plaque	Calcomania
2	55		1	6060131		Schild	SC 7314	Label	Plaque	Calcomania
2	56	1	1	6060248		Schild	MIX	Label	Plaque	Calcomania

SC-7312
SC-7314

3

Schalldämpfer
Muffler
Pot d' échappement
Silencioso

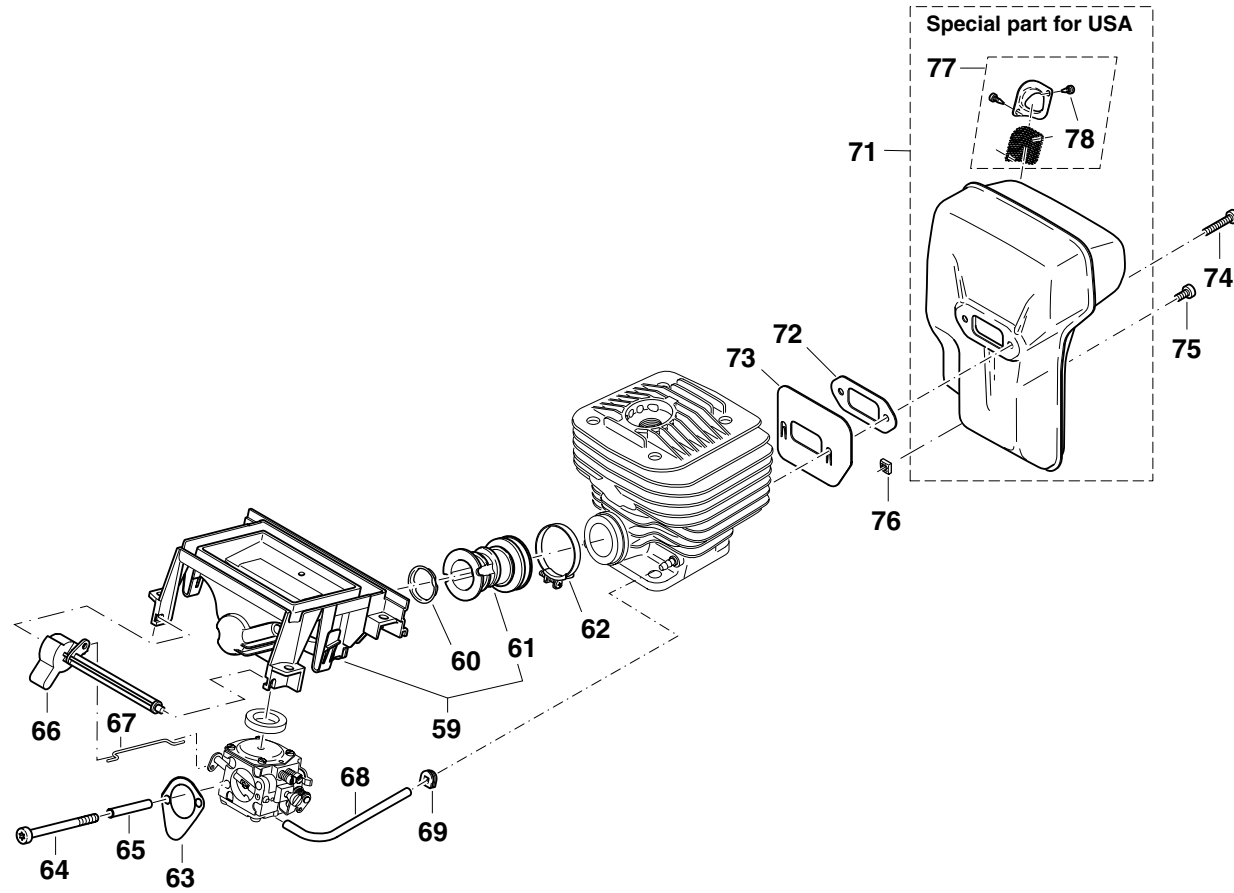

SC 7312, 7314



Seite / Page	Pos.	SC 7312	SC 7314	Speedi Cut Part No.	Hinweise Notes Renseign. Nota	Description	Spezifikation Specification	Bezeichnung	Désignation	Denominación
3	59	1	1	6060143		Ansaugkrümmer kpl.		Connecting sleeve cpl.	Manchon de jonction cpl.	Manguito de conexión cpl.
3	60	1	1	6060008		Einsatz für Ansaugschlauch		Insert for suction hose	Pièce p. tuyau d'aspiration	Suplemento p. tubo d. asp.
3	61	1	1	6060044		Ansaugschlauch		Suction line	Conduite d' aspiration	Conducto de aspiración
3	62	1	1	6060128		Schlauchschele		Hose clip	Collier de serrage	Abrazadera
3	63	1	1	6060161		Dichtung		Gasket	Joint	Junta
3	64	2	2	6060147		Schraube	⊕ M4x55	Screw	Vis	Tornillo
3	65	m	m	6060130		Schlauch	37mm; 1 1/2"	Tube	Gaine	Tubo
3	66	1	1	6060050		Chokewelle		Choke shaft	Axe pour clapet d' air	Eje para válvula de aire
3	67	1	1	6060051		Chokestange		Choke shaft	Levier pour clapet d' air	Palance de válvula de aire
3	68	m	m	6060123		Impulsschlauch	116mm; 4 1/2"	Tube	Gaine	Tubo
3	69	1	1	6060119		Gummitülle		Rubber bush	Gaine caoutchouc	Boquilla de caucho
3	71	1	1	6060066	U.S.A.	Schalldämpfer USA		Muffler	Pot d' échappement	Silencioso
3	72	1	1	6060126		Dichtung		Gasket	Joint	Junta
3	73	1	1	6060067		Abschirmblech		Cover plate	Tôle de protection	Chapa deflectorá
3	74	2	2	6060148		Schraube	⊕ M5x20	Screw	Vis	Tornillo
3	75	1	1	6060085		Schraube	⊕ M5x9	Screw	Vis	Tornillo
3	76	1	1	6060097		4kt-Mutter	M5	Square nut	Ecrou carré	Tuerca cuadr.
3	77	1	1	6060256	U.S.A.	Funkenschutzsieb		Spark arrestor screen	Tamis	Tamiz
3	78	2	2	6060148	U.S.A.	Schraube		Screw	Vis	Tornillo

SC-7312
SC-7314

4

Vergaser
Carburetor
Carburateur
Carburador

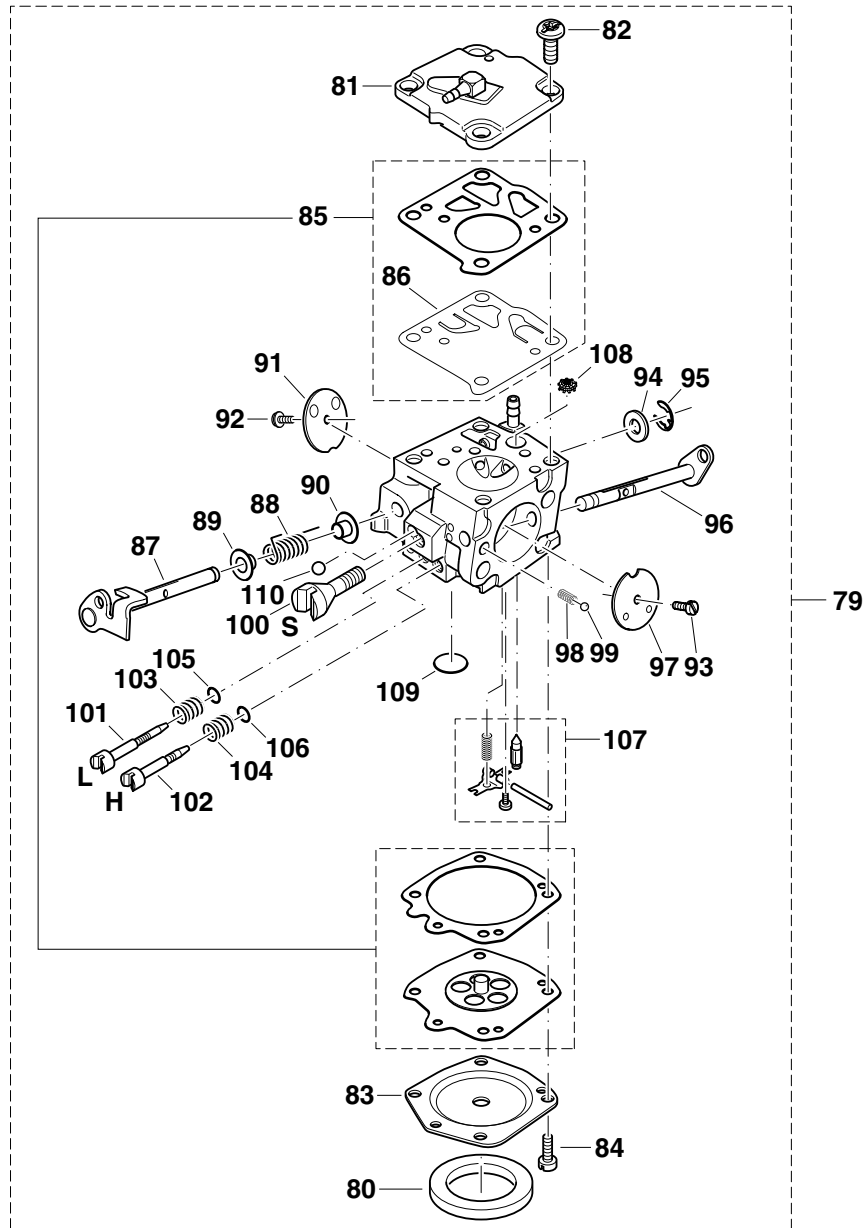

SC 7312, 7314



Seite / Page	Pos.	SC 7312	SC 7314	Speedi Cut Part No.	Hinweise Notes Renseign. Nota	Description	Spezifikation Specification	Bezeichnung	Désignation	Denominación
4	79	1	1	6060052		Vergaser mit Dichtung	HS-273 A	Carburetor with gasket	Carbureteur avec joint	Carburador con junta
4	80	1	1	6060121		Dichtung		Gasket	Joint	Junta
4	81	1	1	6060054		Pumpendeckel kpl.		Pump cover cpl.	Couvercle de pompe cpl.	Tapa de bomba cpl.
4	82	4	4	6060055		Schraube		Screw	Vis	Tornillo
4	83	1	1	6060053		Membrandeckel		Diaphragm cover	Couvercle de membrane	Tapa de membrana
4	84	4	4	6060003		Schraube		Screw	Vis	Tornillo
4	85	1	1	6060109		Membransatz Till. HS Gummi		Set diaphragm / gaskets	Jeu de membranes / joints	Juego membranas / juntas
4	86	1	1	6060016		Pumpenmembrane, Gummi		Pump diaphragm, rubber	Membr. de pompe, cautch.	Membr. d. la bomba, caucho
4	87	1	1	6060058		Drosselklappenwelle		Throttle shaft	Axe clapet d' étranglem.	Eje válvula regulador
4	88	1	1	6060059		Drehfeder		Spring	Ressort	Resorte
4	89	1	1	6060021		Buchse		Bushing	Douille	Casquillo
4	90	1	1	6060021		Buchse		Bushing	Douille	Casquillo
4	91	1	1	6060022		Drosselklappe		Throttle shutter	Clapet d' étranglement	Válvula reguladora
4	92	1	1	6060004		Schraube		Screw	Vis	Tornillo
4	93	1	1	6060004		Schraube		Screw	Vis	Tornillo
4	94	1	1	6060020		Scheibe		Disc	Disque	Disco
4	95	1	1	6060013		Sicherungsscheibe		Safety washer	Rondelle sécurité	Arandela seguridad
4	96	1	1	6060057		Chokewelle		Choke shaft	Axe pour clapet d' air	Eje para válvula de aire
4	97	1	1	6060017		Chokeklappe		Choke shutter	Clapet d' air	Válvula de aire
4	98	1	1	6060014		Arretierfeder		Locking spring	Ressort d' arrêt	Resorte de tope
4	99	1	1	6060018		Arretierkugel		Locking ball	Bille d' arrêt	Bola de tope
4	100	1	1	6060063		Leerlauf-Anschlagschraube	S	Idle stop screw	Vis de butée de ralenti	Tornillo de tope
4	101	1	1	6060060		Leerlauf-Stellschraube	L	Idle adjustment screw	Vis de régl. de ralenti	Tornillo regulador
4	102	1	1	6060062		Vollgas-Stellschraube	H	Main adjustm. screw	Vis de régl. plein gaz	Tornillo regulador
4	103	1	1	6060023		Feder		Spring	Ressort	Resorte
4	104	1	1	6060023		Feder		Spring	Ressort	Resorte
4	105	1	1	6060061		O-Ring		Packing ring	Bague-joint	Anillo de guarnición
4	106	1	1	6060061		O-Ring		Packing ring	Bague-joint	Anillo de guarnición
4	107	1	1	6060110		Satz Steuerteile		Set of control parts	Jeu de pièces de comm.	Juego piezas de mando
4	108	1	1	6060056		Sieb		Screen	Tamis	Tamiz
4	109	1	1	6060015		Verschußscheibe		Cover disc	Disque de fermeture	Disco de sierre
4	110	1	1	6060002		Arretierkugel		Locking ball	Bille d' arrêt	Bola de tope

SC-7312
SC-7314

5

Anwerfvorrichtung, Magnetzünder
Starter, ignition
Dispositif de démarrage, volant magnétique
Dispositivo arranque, volante magnético

SPEEDI CUT
DIAMOND
PRODUCTS

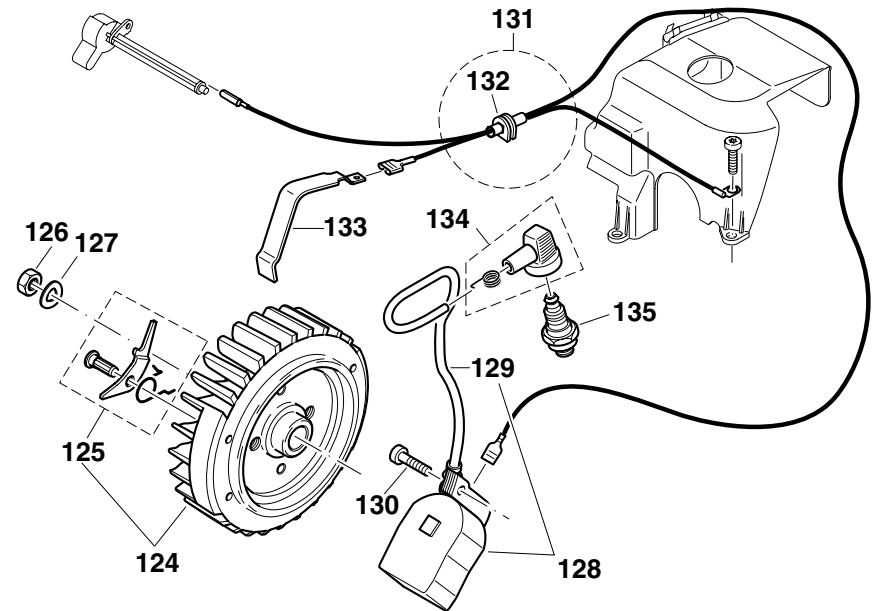
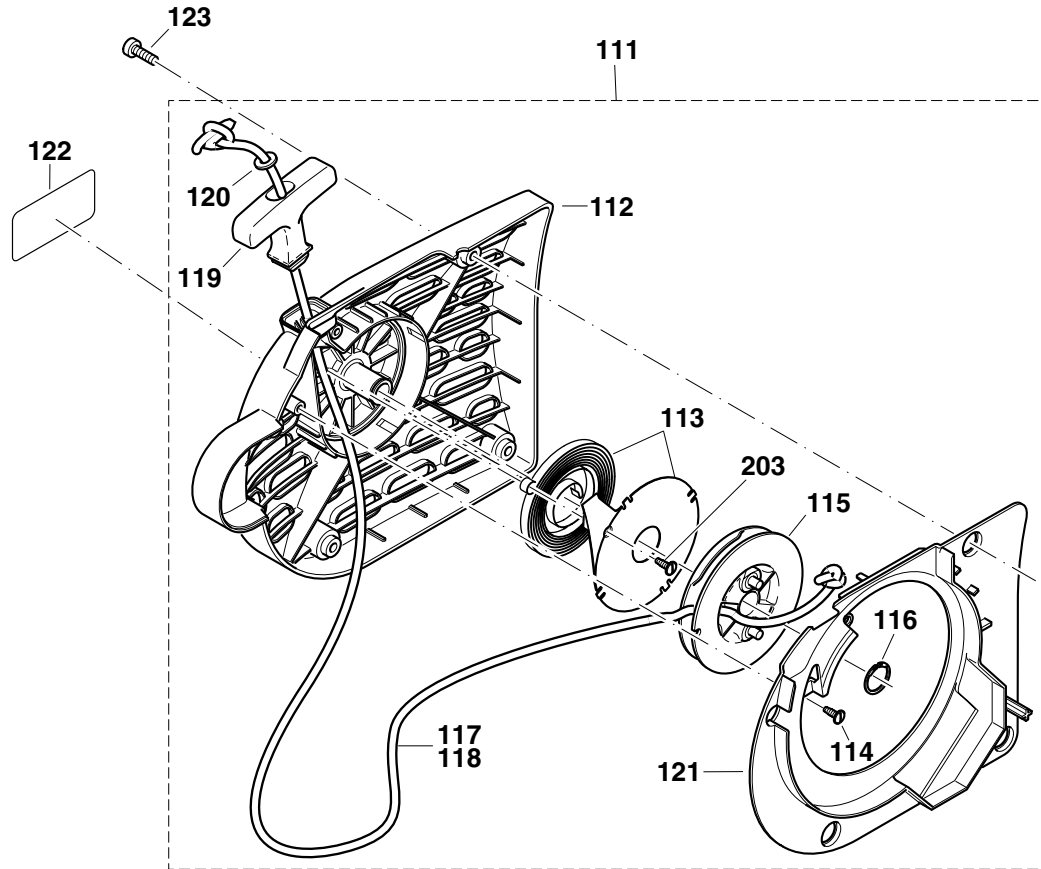

SC 7312, 7314



Seite / Page	Pos.	SC 7312	SC 7314	Speedi Cut Part No.	Hinweise Notes Renseign. Nota	Description	Spezifikation Specification	Bezeichnung	Désignation	Denominación
5	111	1	1	6060031	SI 8/01	Anwerfvorrichtung kpl., rot		Starter assy., red	Dispos. de démarrage cpl., rouge	Dispos. de arranque cpl., rojo
5	112	1	1	6060250		Startergehäuse, rot		Fan housing, red	Carter de ventilateur, rouge	Cárter de ventilador, rojo
5	113	1	1	6060007		Rückholfeder im Gehäuse		Rewind spring in housing	Ressort de rappel dans boî	Resorte retenc. en caja
5	114	2	2	6060095		Schneidschraube	3,5x9,5	Thread forming screw	Vis taraudeuse	Tornillo
5	115	1	1	6060009		Seiltrommel		Cable drum	Tambour de câble	Tambour para cordón
5	116	1	1	6060103		Sicherungsring		Snap ring	Circlip	Anillo seguridad
5	117	1	1	6060165		Anwerfseil	ø4 x 1000mm	Starter rope	Câble de démarrage	Cordón de arranque
5	118	1	1	6060120		Anwerfseil	ø4 x 100m	Starter rope	Câble de démarrage	Cordón de arranque
5	119	1	1	6063036		Anwerfgriff		Starter grip	Poignée de lancement	Tirador de arranque
5	120	1	1	6060102		Spannscheibe		Disc	Disque	Arandela
5	121	1	1	6060030		Luftführung		Air guide plate	Guide d'air	Conducto de aire
5	122	1	1	6060079		Schild Speedi Cut		Label	Plaque	Calcomania
5	123	4	4	6060086		Schraube	✚ M5x16	Screw	Vis	Tornillo
5	124	1	1	6060047		Polrad kpl.		Flywheel assy.	Roue polaire cpl.	Volante encendido
5	125	2	2	6060012		Anwerfklinke kpl.		Starter ratchet cpl.	Cliquet cpl.	Trinquete arranque cpl.
5	126	1	1	6060262		6kt-Mutter	M8x1	Hexagonal nut	Ecrou hexagonal	Tuerca hexagonal
5	127	1	1	6060101		Federscheibe		Spring washer	Rondelle à ressort	Arandela elástica
5	128	1	1	6060048		Magnetzündler		Ignition coil	Bobine d' allumage	Bobina encendido
5	129	m	m	6060129		Zündleitung	360mm; 14 ¹ / ₈ "	Ignition cable	Câble d' allumage	Cable encendido
5	130	2	2	6060092		Schlitz-Schraube	✚ M5x20	Screw	Vis	Tornillo
5	131	1	1	6060162		Kabel mit Stecker		Cable with plug	Câble avec prise	Cable con enchufe
5	132	1	1	6060119		Gummitülle		Rubber bush	Gaine caoutchouc	Boquilla de caucho
5	133	1	1	6060049		Kontaktfeder		Contact spring	Ressort de contact	Resorte de contacto
5	134	1	1	6060112		Zündkerzenstecker kpl.		Spark plug cap cpl.	Fiche de bougie, cpl.	Tapa de bujia cpl.
5	135	1	1	6060127		Zündkerze		Spark plug	Bougie	Bujia
5	203	1	1	6060095		Schneidschraube	3,5x9,5	Thread forming screw	Vis taraudeuse	Tornillo

SC-7312
SC-7314

6

Zylinder, Kurbeltrieb, Kupplung
Cylinder, crankshaft, clutch
Cylindre, vilebrequin, embrayage
Cilindro, cigüeñal, embrague

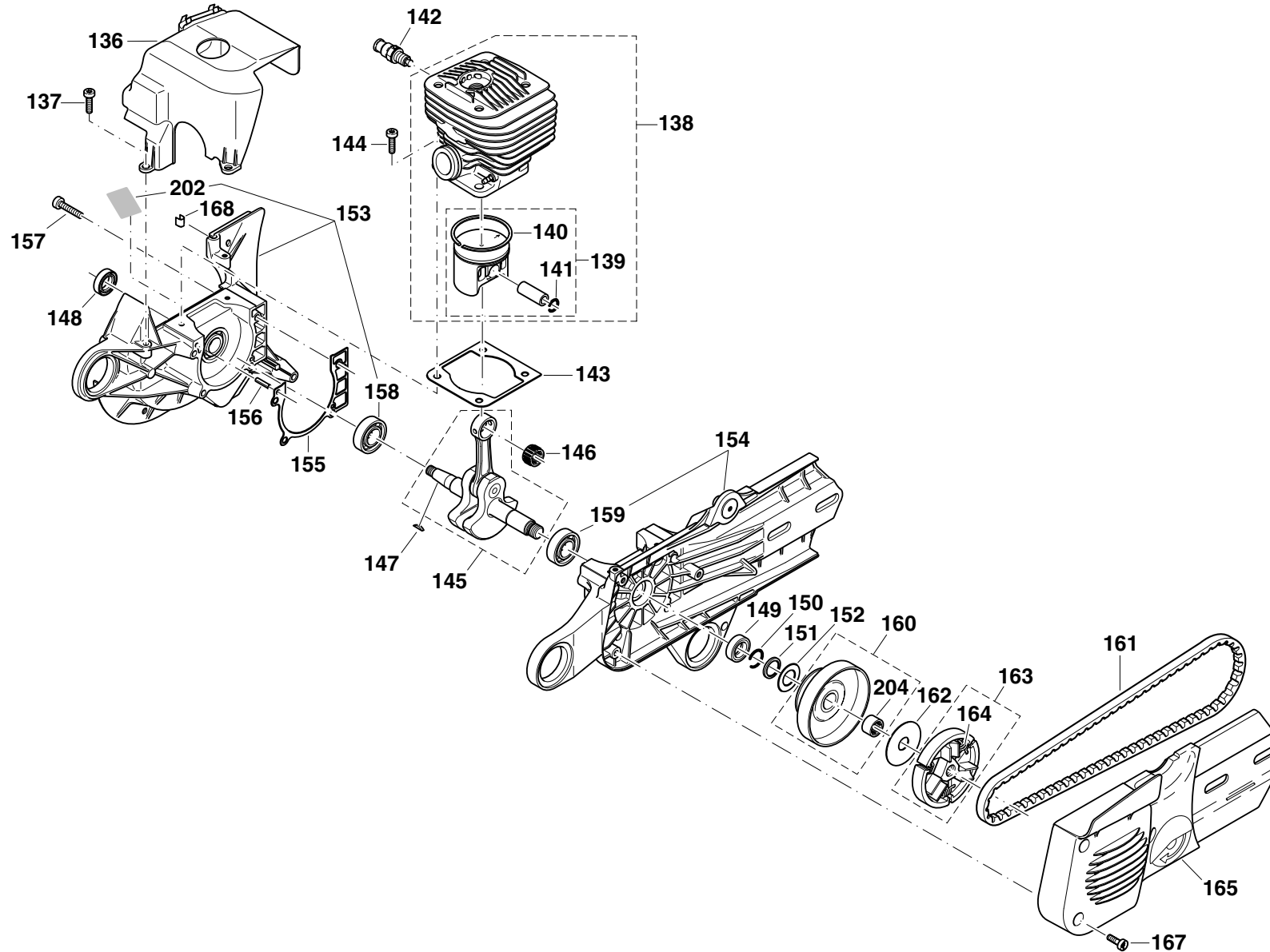

SC 7312, 7314



Seite / Page	Pos.	SC 7312	SC 7314	Speedi Cut Part No.	Hinweise Notes Renseign. Nota	Description	Spezifikation Specification	Bezeichnung	Désignation	Denominación
6	136	1	1	6060043		Kühlfluthaube, schwarz		Hood, black	Capot, noir	Cubierta, negro
6	137	3	3	6060086		Schraube	⊕ M5x16	Screw	Vis	Tornillo
6	138	1	1	6060134		Zylinder / Kolben, kpl.	∅ 50	Cylinder / piston, cpl.	Cylindre et piston, cpl.	Cilindro con pistón, cpl.
6	139	1	1	6060046		Kolben AB kpl.	∅ 50	Piston cpl.	Piston cpl.	Pistón cpl.
6	140	1	1	6060045		Kolbenring	∅ 50	Piston ring	Segment de piston	Segmento de pistón
6	141	2	2	6060019		Sprengring		Spring ring	Anneau-ressort	Anillo elástico
6	142	1	1	6060001		Dekompressionsventil		Decompression valve	Soupape de décompres.	Válvula de decompresión
6	143	1	1	6060340		Zylinderfußdichtung		Gasket	Joint	Junta
6	144	4	4	6060087		Schraube	⊕ M5x20	Screw	Vis	Tornillo
6	145	1	1	6060042		Kurbelwelle kpl.		Crankshaft cpl.	Vilebrequin cpl.	Cigüeñal cpl.
6	146	1	1	6060114		Nadelkäfig		Needle cage	Cage à aiguilles	Jaula de agujas
6	147	1	1	6060106		Scheibenfeder		Key	Clavette	Chaveta
6	148	1	1	6060115		Radialdichtring	∅15/24x7	Radial ring	Joint radial	Junta radial
6	149	1	1	6060115		Radialdichtring	∅15/24x7	Radial ring	Joint radial	Junta radial
6	150	1	1	6060104		Sprengring		Spring ring	Anneau-ressort	Anillo elástico
6	151	1	1	6060005		Anschlagring, gehärtet, verzinkt		Stop ring, hardened	Bague de butée, durcie	Anillo de deten., endurecido
6	152	1	1	6060068		Führungsscheibe		Guide disc	Disque de guidage	Disco de guía
6	153	1	1	6060028		Kurbelgehäuse kpl. MS, schwarz		Crankc., mag. side, black	Carter-coté, magn., noir	Cárter cig., lado mag., negro
6	154	1	1	6060029		Kurbelgehäuse kpl. KS, schwarz		Crankc., clutch side, black	Carter-coté, embr., noir	Cárter cig., lado embr., negro
6	155	1	1	6060124		Kurbelgehäusedichtung		Gasket	Joint	Junta
6	156	2	2	6060105		Spiralspannstift		Spiral clamping pin	Goupille	Pasador
6	157	5	5	6060088		Schraube	⊕ M5x30	Screw	Vis	Tornillo
6	158	1	1	6060113		Kugellager (einkleben)		Ball bearing (use glue)	Roulement à billes (à coller)	Rodam. de bolas (a colar)
6	159	1	1	6060113		Kugellager (einkleben)		Ball bearing (use glue)	Roulement à billes (à coller)	Rodam. de bolas (a colar)
6	160	1	1	6060075		Kupplungstrommel kpl.		Clutch drum assy.	Tambour cpl.	Tambor cpl.
6	161	1	1	6060118		Keilriemen		V-belt	Courroie trapez	Correa estrecho
6	162	1	1	6060010		Führungsscheibe		Guide disc	Disque de guidage	Disco de guía
6	163	1	1	6060006		Kupplung kpl.		Clutch assy.	Embrayage cpl.	Embrague cpl.
6	164	3	3	6060011		Zugfeder		Spring	Ressort	Resorte
6	165	1	1	6060072		Abdeckung mit Schlitz, rot		Cover, red	Couvercle, rouge	Cubierta, rojo
6	167	3	3	6060091		Schlitz-Schraube	⊕ M5x14	Screw	Vis	Tornillo
6	168	1	1	6060251		Fixiergummi, Satz = 35 Stück		Rubber plate, set=35 pcs.	Plaque de caoutch., jeu=35 piè	Plancha de cau., jue.=35pzs.
6	202	1	1	6060257		Isolationsfolie		Insulating sheet	Feuille isolante	Hoja aislante
6	204	1	1	6060263		Nadelhülse		Needle bush	Roulement à aiguilles	Jaula de agujas

SC-7312
SC-7314

7

Schneidvorsatz, Schutzhaube
Cutting device, protection hood
Dispositif de coupe, capot de protection
Dispositivo tranzadora, cubierta protectora

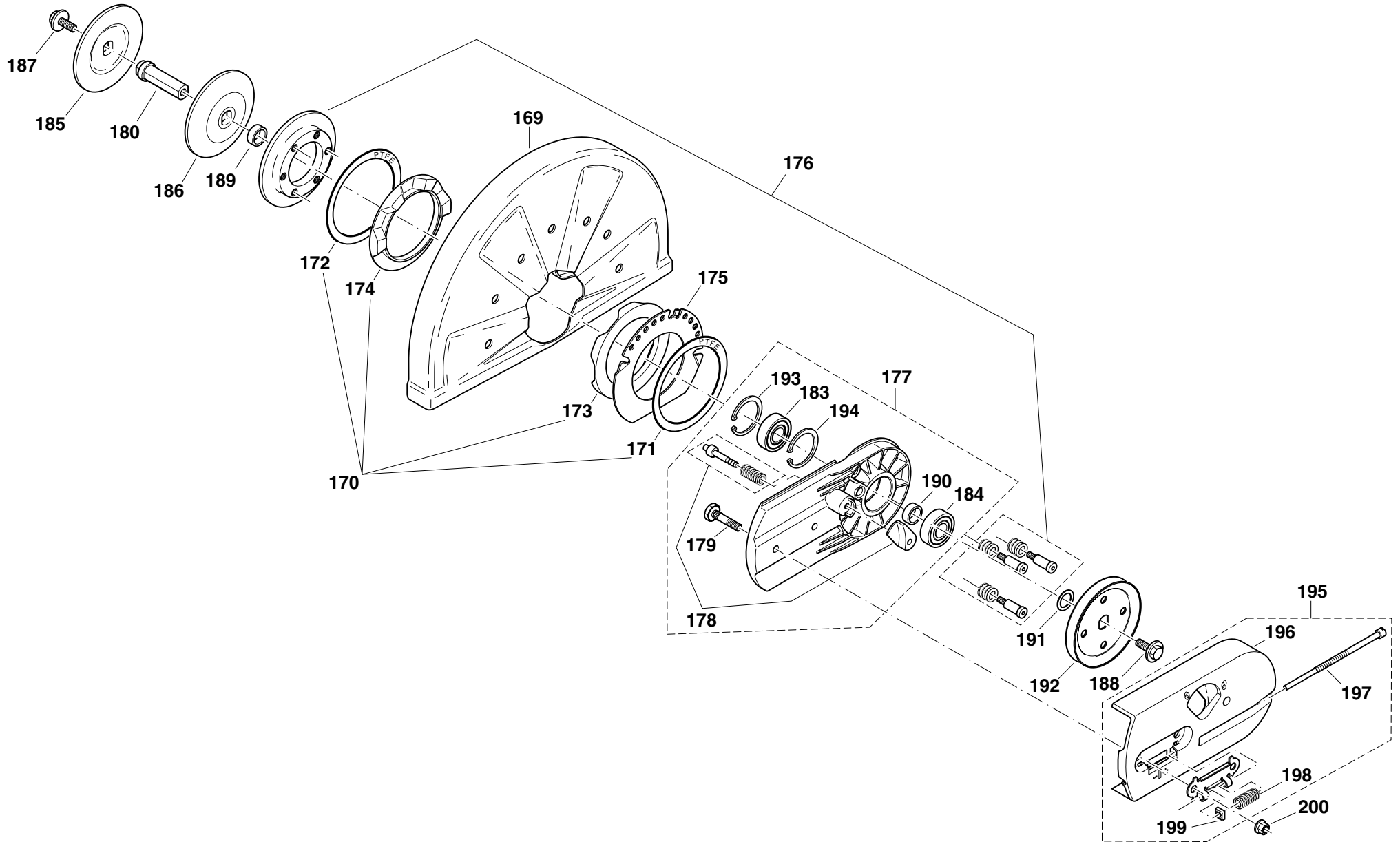

SC 7312, 7314



Seite / Page	Pos.	SC 7312	SC 7314	Speedi Cut Part No.	Hinweise Notes Renseign. Nota	Description	Spezifikation Specification	Bezeichnung	Désignation	Denominación
7	169	1		6060027		Schutzhaube, silber	ø 300mm; 12"	Prot. hood, silver	Capot de protection, d'argent	Cubierta protec., plateado
7	169		1	6060081		Schutzhaube, silber	ø 350mm; 14"	Prot. hood, silver	Capot de protection, d'argent	Cubierta protec., plateado
7	170	1	1	6060156		Aufnahme Schutzhaube kpl.		Prot. hood mounting, cpl.	Logement capot de prot. cpl.	Alojamiento cub. prot., cpl.
7	171	1	1	6060252		Gleitscheibe Teflon		Sliding disc	Disque de glissement	Arandela deslizante
7	172	1	1	6060252		Gleitscheibe Teflon		Sliding disc	Disque de glissement	Arandela deslizante
7	173	1	1	6060253		Gummiring außen		Rubber ring ext.	Bague en caoutchouc ext.	Anillo de goma exterior
7	174	1	1	6060254		Gummiring innen		Rubber ring int.	Bague en caoutchouc int.	Anillo de goma interior
7	175	1	1	6060146		Rastblech		Locking plate	Tôle d'arrêt	Chapa descanso
7	176	1	1	6060083		Druckring kpl., schwarz		Pressure ring cpl., black	Bague de pression cpl., noir	Anillo de presión cpl., negro
7	177	1	1	6060071		Schneidvorsatz kpl., schwarz		Cutting device assy., black	Dispositif de coupe cpl., noir	Dispos. tranzadora cpl., negro
7	178	1	1	6060111		Hauben-Arretierbolzen kpl.		Bolt cpl.	Boulon cpl.	Bulon cpl.
7	179	2	2	6060069		Bef.-Schraube gerändelt		Screw	Vis	Tornillo
7	180	1	1	6060078		Achse	ø 20mm	Axle	Axe	Eje
7	183	1	1	6060157		Kugellager		Ball bearing	Roulement à billes	Rodamiento de bolas
7	184	1	1	6060157		Kugellager		Ball bearing	Roulement à billes	Rodamiento de bolas
7	185	1	1	6060077		Spannflansch		Pressure disc	Disque de pression	Disco de presión
7	186	1	1	6060077		Spannflansch		Pressure disc	Disque de pression	Disco de presión
7	187	1	1	6060136		6kt-Schraube	M8x25	Hexagonal screw	Vis hexagonal	Tornillo hexagonal
7	188	1	1	6060136		6kt-Schraube	M8x25	Hexagonal screw	Vis hexagonal	Tornillo hexagonal
7	189	1	1	6060076		Distanzhülse		Spacer	Douille de distance	Casquillo separador
7	190	1	1	6060076		Distanzhülse		Spacer	Douille de distance	Casquillo separador
7	191	1	1	6060084		Paßscheibe		Disc	Disque	Arandela
7	192	1	1	6060074		Keilriemenscheibe		V-belt pulley	Poulie à gorge	Polea para correa
7	193	1	1	6060149		Sicherungsring		Snap ring	Circlip	Anillo seguridad
7	194	1	1	6060149		Sicherungsring		Snap ring	Circlip	Anillo seguridad
7	195	1	1	6060070		Abdeckung Schneidvors. kpl., rot		Cover cpl., red	Couvercle cpl., rouge	Cubierta cpl., rojo
7	196	1	1	6060255		Abdeckung Schneidvors., rot		Cover, red	Couvercle, rouge	Cubierta, rojo
7	197	1	1	6060073		Spannschraube		Tensioning screw	Vis de tension	Tornillo de tensión
7	198	1	1	6060082		Druckfeder		Spring	Ressort	Resorte
7	199	1	1	6060098		4kt-Mutter	M6	Square nut	Ecrou carré	Tuerca cuadr.
7	200	2	2	6060099		6kt-Mutter mit Bund	M8	Hexagonal nut	Ecrou hexagonal	Tuerca hexagonal

SC-7312
SC-7314

8

Werkzeug
Tools
Outils
Herramientas



300

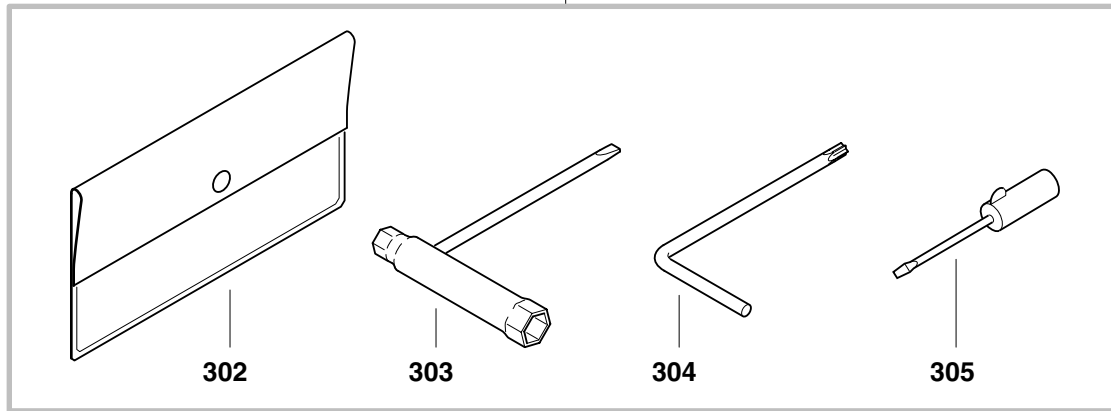

306

SC 7312, 7314



Seite / Page	Pos.	SC 7312	SC 7314	Speedi Cut Part No.	Hinweise Notes Renseign. Nota	Description	Spezifikation Specification	Bezeichnung	Désignation	Denominación
8	300	1	1	6060155		Werkzeug kpl.		Tools cpl.	Outils cpl.	Herramientas cpl.
8	302	1	1	6060154		Werkzeugtasche		Plastik bag	Pochette en plastique	Cartera herramientas
8	303	1	1	6060151		Kombischlüssel	SW 13/19	Universal wrench	Clé combinée	Llave de bujía
8	304	1	1	6060150		Winkelschraubendreher	✶	Angled screw driver	Clé angle	Llave angular
8	305	1	1	6060152		Schraubendreher		Screw driver	Tournevis	Destornillador
8	306	1	1	6060144	Acc.	Adaptring	ø 20/25,4 mm	Adapter	Adaptateur	Adaptor

SC-7312
SC-7314

9

Wasseranschluß • Nicht im Lieferumfang
Water attachment • Not included in delivery
Raccordement d'eau • Non incl. dans la livraison
Acometida de agua • No incluidos en entrega

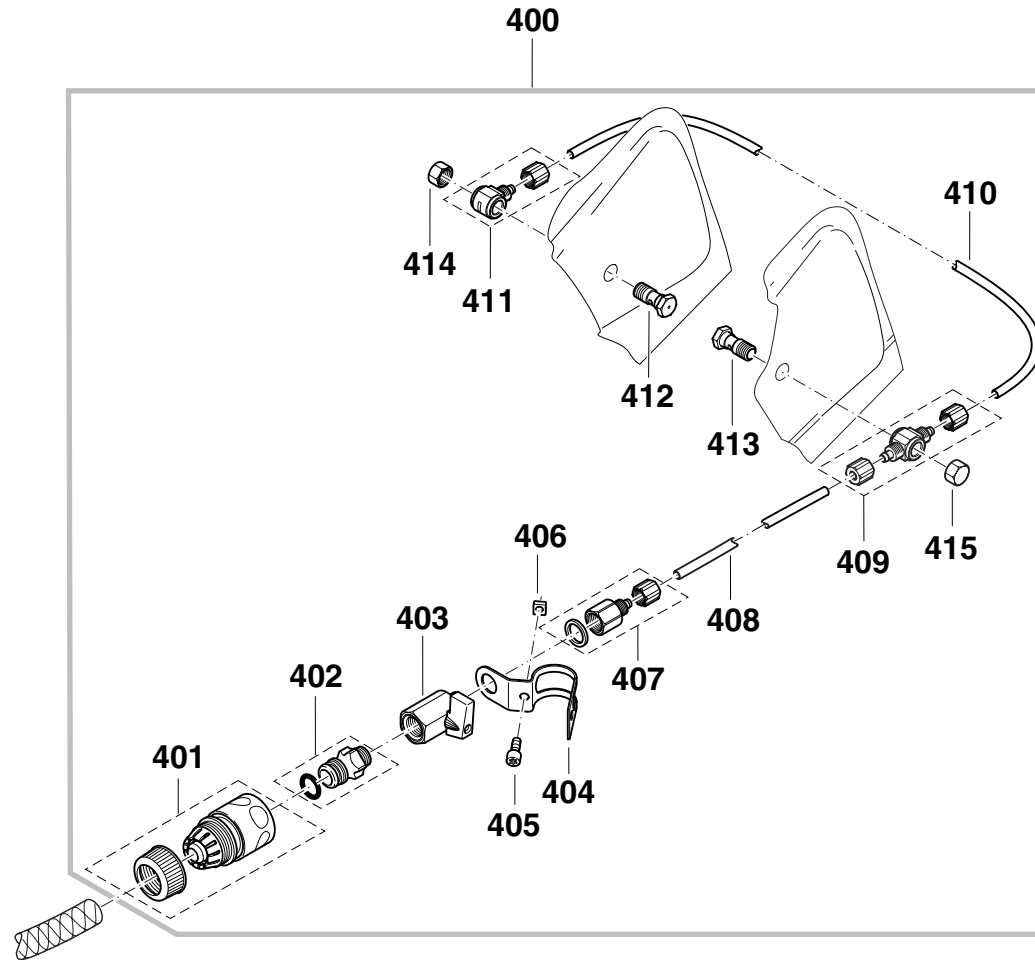

SC 7312, 7314



Seite / Page	Pos.	SC 7312	SC 7314	Speedi Cut Part No.	Hinweise Notes Renseign. Nota	Description	Spezifikation Specification	Bezeichnung	Désignation	Denominación
9	400	1	1	6060166		Druck-, Fallwasserarmatur		Water attachment kit	Jeu de raccordement d'eau	Acometida de agua
9	401	1	1	6060167		Schlauchkupplung STOP		Coupling sleeve STOP	Manchon d'accouplement	Acoplamiento p. tubos
9	402	1	1	6060168		Einschraubnippel		Hose connector	Raccord pour tuyau	Boquilla roscada
9	403	1	1	6060169		Kugelventil		Shut off cock	Robinet d'arrêt	Llave de paso
9	404	1	1	6060170		Schelle		Clamp	Bride de fixation	Abrazadera
9	405	1	1	6060159		Schraube	☛ M6x10	Screw	Vis	Tornillo
9	406	1	1	6060098		4kt-Mutter	M6	Square nut	Ecrou carré	Tuerca cuadr.
9	407	1	1	6060171		Schnellverschraubung		Connecting piece	Pièce de raccord	Pieza de unión
9	408	m	m	6060172		PU-Schlauch	405mm; 16"	Hose	Tuyau	Tubo
9	409	1	1	6060173		Schnellverschraubung T		Connecting piece T	Pièce de raccord	Pieza de unión
9	410	m		6060172		PU-Schlauch	180mm; 7"	Hose	Tuyau	Tubo
9	410		m	6060172		PU-Schlauch	210mm; 8 1/4"	Hose	Tuyau	Tubo
9	411	1	1	6060174		Schnellverschraubung L		Connecting piece L	Pièce de raccord	Pieza de unión
9	412	1	1	6060175		Hohlschraube (Düse)		Nozzle	Tuyère	Tobera
9	413	1	1	6060175		Hohlschraube (Düse)		Nozzle	Tuyère	Tobera
9	414	1	1	6060153		Hutmutter		Cap nut	Écrou borgne	Tuerca
9	415	1	1	6060153		Hutmutter		Cap nut	Écrou borgne	Tuerca

State of California Special Warning:

Warning: This product contains a chemical known to the State of California to cause cancer and/or birth defects or other reproductive harm.



333 Prospect Street
ELYRIA, OHIO 44035
(800) 323-5336
<http://www.diamondproducts.com>