



**CORE CUT
PARTS LIST MANUAL**

**CC1300XL
ELECTRIC / HYDRAULIC**

MARCH, 2023

Part #: 1801809-12

RECOMMENDED POWER CORD GAUGE

HORSE POWER	PHASE	VOLTS	AMPS	50 Ft. CORD	100 Ft. CORD	150 Ft. CORD	200 Ft. CORD
5hp	1ph	230v	23A	#10	#8	#6	#4
5hp	3ph	230v	12A	#14	#12	#10	#8
5hp	3ph	460v	6A	#14	#14	#12	#10
7.5hp	1ph	230v	33A	#8	#8	#6	#4
10hp	3ph	230v	24A	#10	#8	#6	#4
10hp	3ph	460v	12A	#14	#12	#10	#8
20hp	3ph	230v	52A	#6	#6	#4	#2
20hp	3ph	460v	26A	#10	#8	#6	#4
25hp	3ph	230v	58A	#6	#6	#4	#2
25hp	3ph	460v	29A	#10	#8	#6	#4
30hp	3ph	230v	74A	#6	#4	#2	#1
30hp	3ph	460v	37A	#8	#6	#4	#2
40hp	3ph	460v	48A	#8	#6	#4	#2
50hp	3ph	460v	62A	#4	#4	#2	#0

CAUTION: Use of a wire gauge that is too small will cause loss of power or overheating and will damage the electric motor.

GENERAL SAFETY WARNINGS AND PRECAUTIONS

PERSONAL SAFETY

- Read and understand all operating instructions before attempting to operate the saw.
- Always wear safety approved hearing, eye, head and respiratory protection.
- Always wear sturdy boots with non-slip soles to ensure proper footing. Use of steel toed safety boots is recommended.
- Due to the nature of concrete cutting, sparks may be generated therefore never wear clothing that is made of flammable material.
- Know how to stop the saw quickly in case of emergency.
- Keep all parts of your body away from the blade and all other moving parts.
- Use caution and follow all instructions when loading and unloading the saw.
- Electric Units: disconnect power cord prior to changing the blade or performing maintenance.

BLADE SAFETY

- Examine cutting blades before each use. Blade should have no cracks, nicks, or flaws. The center hole must be undamaged. Use only blades recommended for your particular model saw.
- The saw should only be used for cutting material that is specified on each cutting blade. Read the instructions provided with each blade to determine which material the blade is designed to cut.
- Use only reinforced abrasive blades or steel centered diamond blades manufactured for use on concrete saws.
- Inspect blade flanges for damage, excessive wear and cleanliness before mounting the blade. The blade must fit snugly on the clean, undamaged blade shaft.
- Observe the specified maximum speed of the blade. Never use a blade that has a lower maximum operating speed than the blade shaft speed.
- The ignition governor is designed to limit the maximum no-load engine speed. Speeds in excess of that may cause the blade to exceed the maximum blade speed. Do not operate the unit at speeds greater than the maximum blade speed.
- Always keep guards in place and never allow the blade exposure on the guard to exceed 180 degrees. Repair or replace damaged guards immediately.
- Never expose anyone to the direct line of the blade.
- Make sure that the blade does not come in contact with the ground or any other surface when transporting the saw.

GENERAL SAW SAFETY

- The saw must never be left unattended when the engine is running.
- Keep both hands on the handles when operating the saw.
- Use caution and slow speed when using the self propelled drive to move the saw up or down ramps or when loading and unloading from trucks or trailers. When going down ramps, DRIVE the saw forward slowly. When going up ramps, BACK the saw in reverse slowly. Always position yourself on the high side of the slope.
- Gas Units: never operate the saw if there is a fuel leak.

CUTTING / WORK AREA SAFETY

- Never operate the saw in any application or job in which you are not trained or supervised.
- Always ensure that the work area does not contain any buried or embedded electrical lines, gas lines or water lines. Ensure that all electric, gas and water lines that may be buried or embedded in the ground, floor, walls or ceilings are shut off prior to cutting.
- Keep bystanders and animals out of the work area.
- Do not operate the saw in areas which contain combustible material or fumes. Sparks may occur from cutting that could cause a fire or explosion.
- Gas Units: operate the saw only in well ventilated areas. Engine exhaust contains carbon monoxide which can cause loss of consciousness and death.
- Gas Units: observe all safety regulations for the safe handling of fuel. Store fuel in appropriate safety containers. Shut off the engine and allow it to cool prior to fueling. Wipe off any spilled fuel. Always move away from the fueling area prior to starting saw.

Concrete cutting as all construction work is inherently dangerous!

Failure to comply with the preceding warnings could result in serious bodily injury!

Table of Contents

<u>Description</u>	<u>Page No.</u>
Common Parts.....	6
Front Axle Assembly.....	8
Screw Feed Assembly.....	9
Motor Assembly, 5HP, 230V, 1 Phase.....	10
Motor Assembly, 5HP, 230V, 3 Phase.....	12
Motor Assembly, 5HP, 460V, 3 Phase.....	14
Motor Assembly, 10HP, 230V, 3 Phase.....	16
Motor Assembly, 10HP, 460V, 3 Phase	18
Motor Assembly, 10HP, 575V, 3 Phase	20
Starter Box Assembly, 3 Phase, 220-240V.....	22
Starter Box Assembly, 3 Phase, 415-480V.....	23
Starter Box Assembly, 3 Phase, 550-600V.....	25
Starter Box, 220-240V	26
Starter Box, 415-480V	28
Starter Box, 550-600V	30
Hydraulic Motor Options, 1.14, 1.55, 1.94 Cubic Inch	32-37
Blade Shaft Assembly.....	38
Blade Shaft Assembly (10HP, 230/460V Units)	39
Blade Shaft Assembly (10HP, 575V Units)	40
14" Blade Guard Assembly	41
18" Blade Guard Assembly	42
20" Blade Guard Assembly	43
Pointer Assembly	44
Pointer Assembly (10HP Units).....	45
Warranty.....	Rear Cover

6090147 CC1300 XL COMMON PARTS

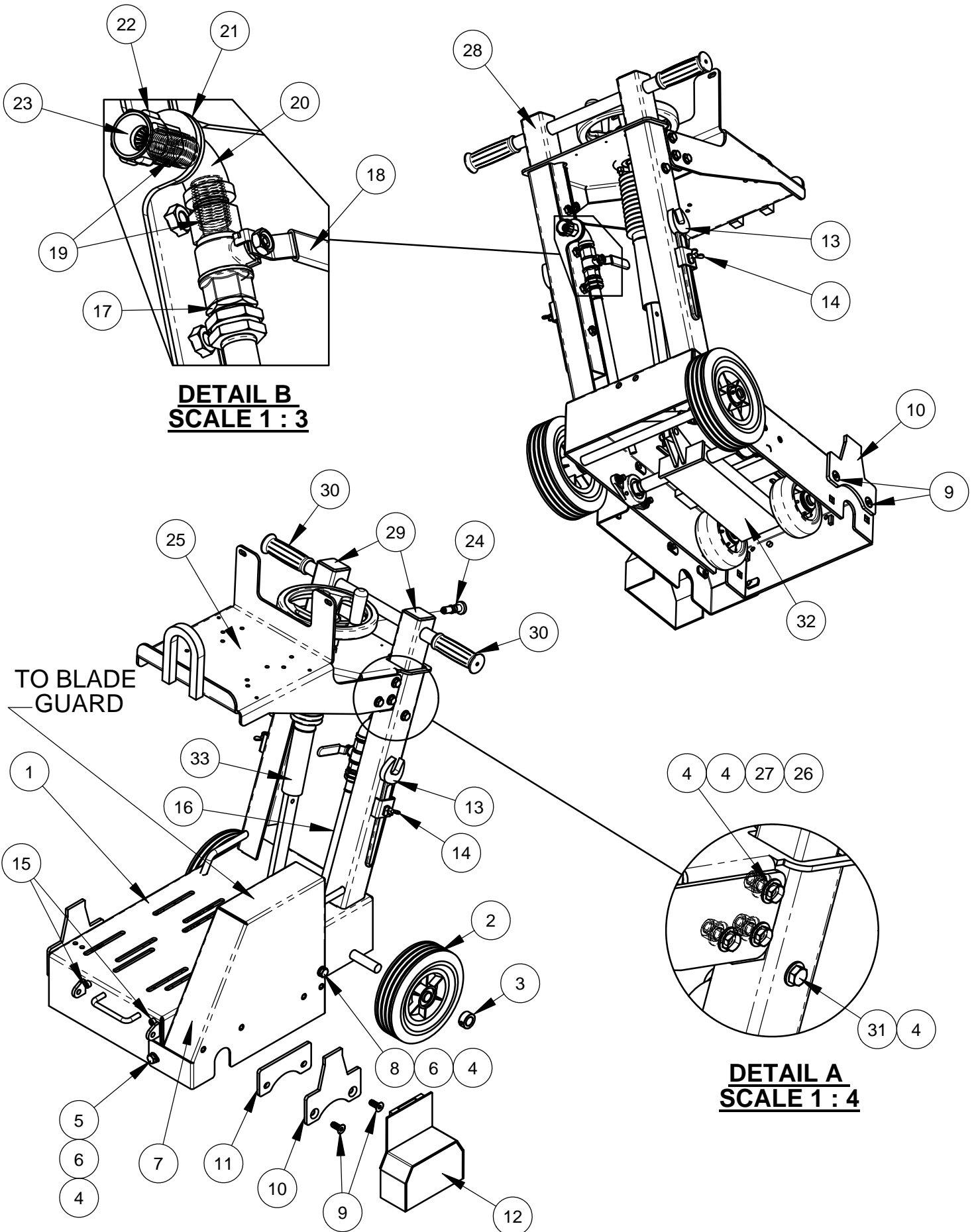

CC1300XL Common Parts - 6090147 (Regular Cut)
- 6048877 (Upcut)

ITEM	PART NO.	QTY.	DESCRIPTION
1	6048181	1	Frame Weldment (Regular Cut)
	6048269	1	Frame Weldment (Upcut)
2	2501439	2	Wheel, 8 x 2 x 3/4"
3	2400615	2	Set Collar, 3/4"
4	2900014	16	Flat Washer, 3/8" SAE
5	2900314	1	Cap Screw, Hex Hd., M10-1.5 x 20mm
6	2900321	2	Lock Washer, M10 Split
7	6048001	1	Belt Guard (Regular Cut)
	6048149	1	Belt Guard (Upcut)
8	2900320	1	Cap Screw, Hex Hd., M10-1.5 x 100mm
9	2900744	4	Capscrew, Flat Hd., M10 x 25mm
10	6049024	2	Tapered Guard Mount
11	6048915	1	Tapered Guard Mount Spacer
12	6048906	1	Shaft Guard
13	2500256	2	Wrench Head
14	2900307	2	Wing Screw, M6 x 16mm
15	2900980	2	Capscrew, Soc. Hd., M8-1.25 x 8mm
16	6011055	1	Water Hose Assembly 30"
17	3200155	1	Fitting, 1/2" M. Pipe to 3/4" M. Garden
18	3200027	1	Water Valve
19	3200008	2	Close Nipple, 1/2" NPT
20	3200209	1	Pipe Elbow, 1/2" Female
21	2900425	1	Flat Washer, 7/8" SAE
22	3200022	1	Fitting, 1/2" F. Pipe to 3/4" F. Garden
23	3200025	1	Hose Filter Washer
24	2400138	1	Indexing Plunger 1/2-13
25	6030318	1	Lift Bar Assembly
26	2900018	6	Locknut, 3/8-16, Nylon
27	2900005	6	Cap Screw, Hex Hd., 3/8-16 x 1"
28	6040213	1	Sliding Handle Weldment
29	2501441	2	Cap, 2" Sq. Tube
30	2500636	2	Handle Grip
31	2900596	2	Cap Screw, Hex Hd., 3/8-16 x 2-1/2"
32	6048184	1	Front Axle Assembly
33	6048183	1	Screw Feed Assembly

6048184 Front Axle Assembly

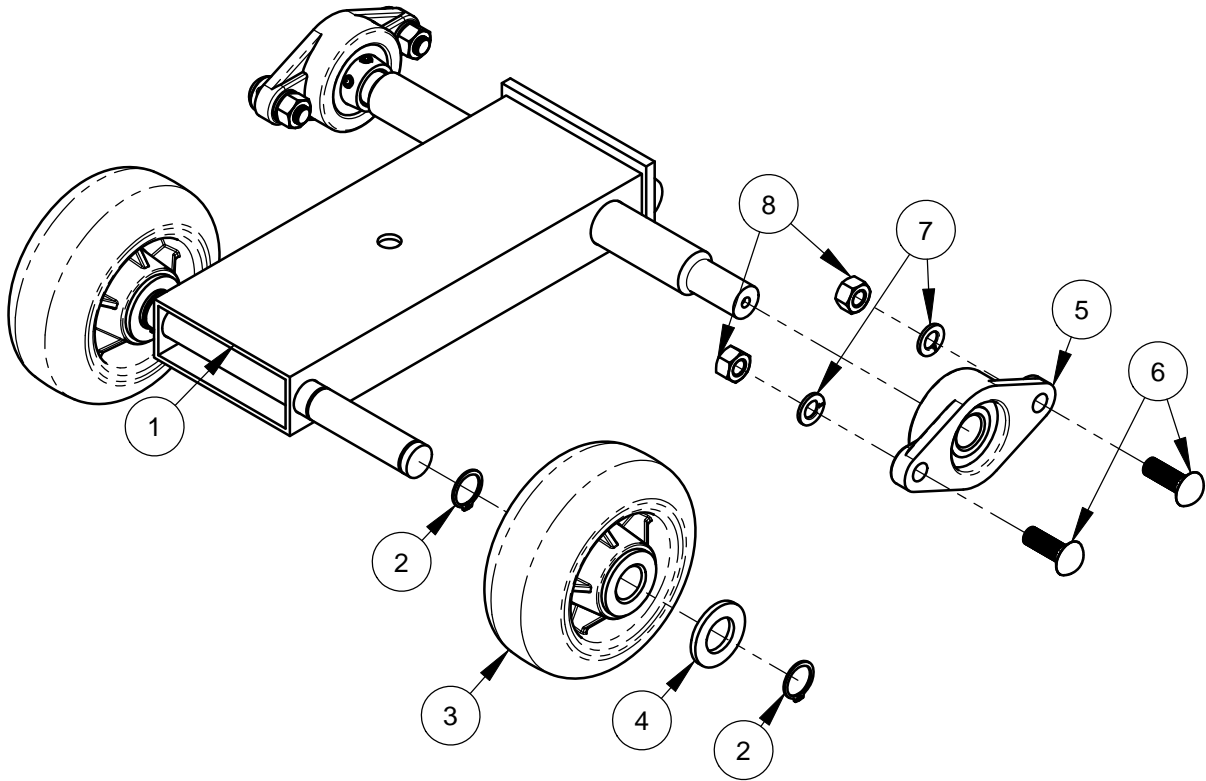

ITEM	PART NO.	QTY.	DESCRIPTION
1	6040212	1	Front Axle Weldment
2	2501186	4	Retaining Ring, External 3/4"
3	2500005	2	Wheel, 5" x 2" x 3/4"
4	2900003	2	Flat Washer, 3/4" SAE
5	2500011	2	Flg Mnt Brg 3/4" Peer UCFT204-12-90
6	2900324	4	Carriage Bolt, M10-1.75 x 30
7	2900321	4	Lock Washer, M10 Split
8	2900304	4	Lock Nut, M10-1.5 Nylon Insert

Screw Feed Assembly #6048183

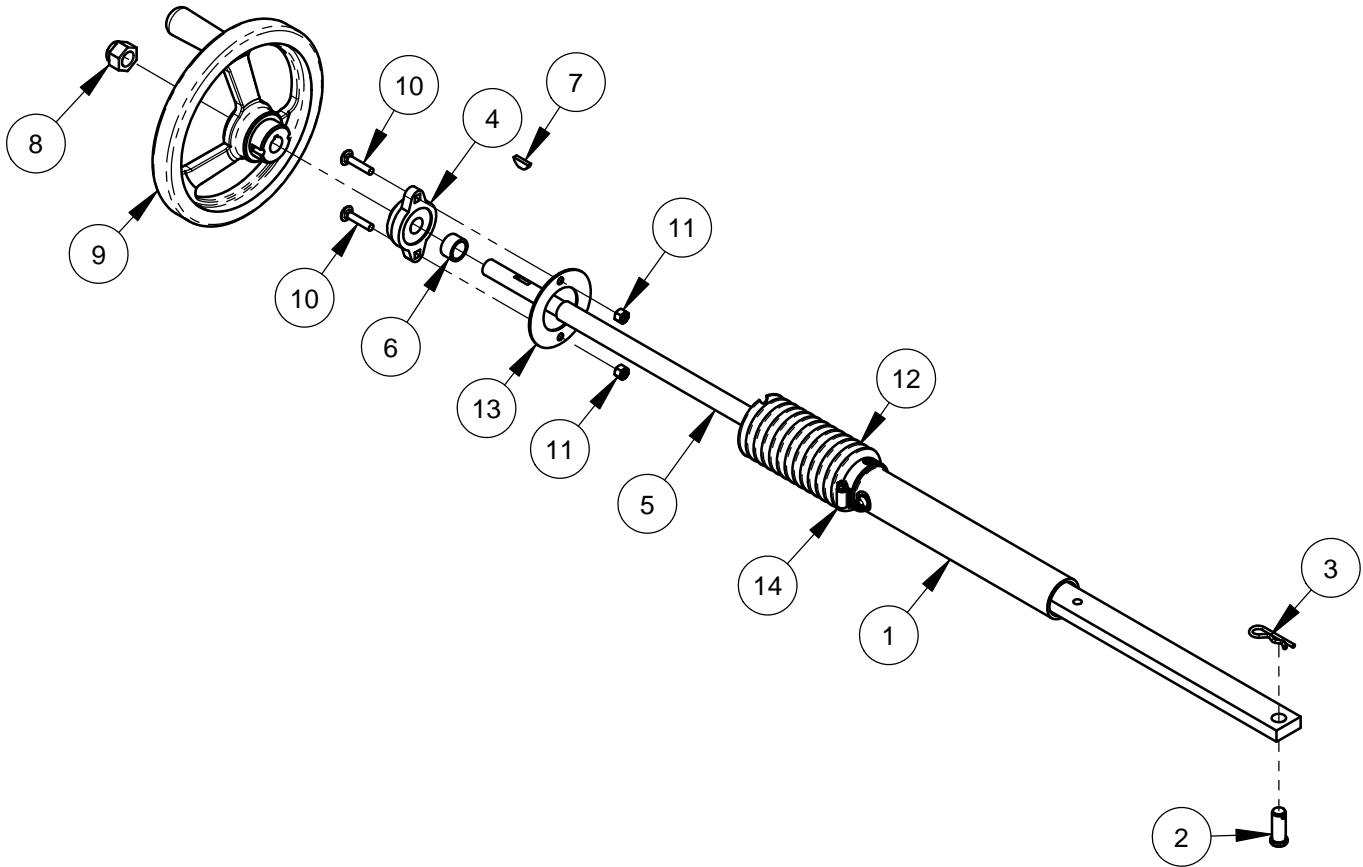

ITEM	PART NO.	QTY	DESCRIPTION
1	6047928	1	Adjustment Shaft W/Grease Fitting
2	2900266	1	Clevis Pin, 1/2 x 1-1/4"
3	2900276	1	Hairpin Cotter, 1/8" x 1/2" to 3/4"
4	2500807	1	Bearing, 5/8", Two Bolt Flange
5	6047929	1	Adjustment Screw
6	6047931	1	Spacer Tube 7/8 x 1/2
7	2900352	1	Woodruff Key, 5/32 x 3/4, #506
8	2900355	1	Lock Nut, 5/8-18, Flex Top
9	2500800	1	Handwheel, 8" x 5/8"
10	2900373	2	Carriage Bolt, 1/4-20 x 1-1/4", GR5
11	2900010	2	Lock Nut, 1/4-20 Nylon
12	6048036	1	Bellow, 5-1/2"
13	6048038	1	Bellow Mount Washer
14	3202142	1	Hose Clamp #24

6041347 CC1300 XL ELECTRIC MOTOR OPTION, 5HP, 230V, 1-PHASE

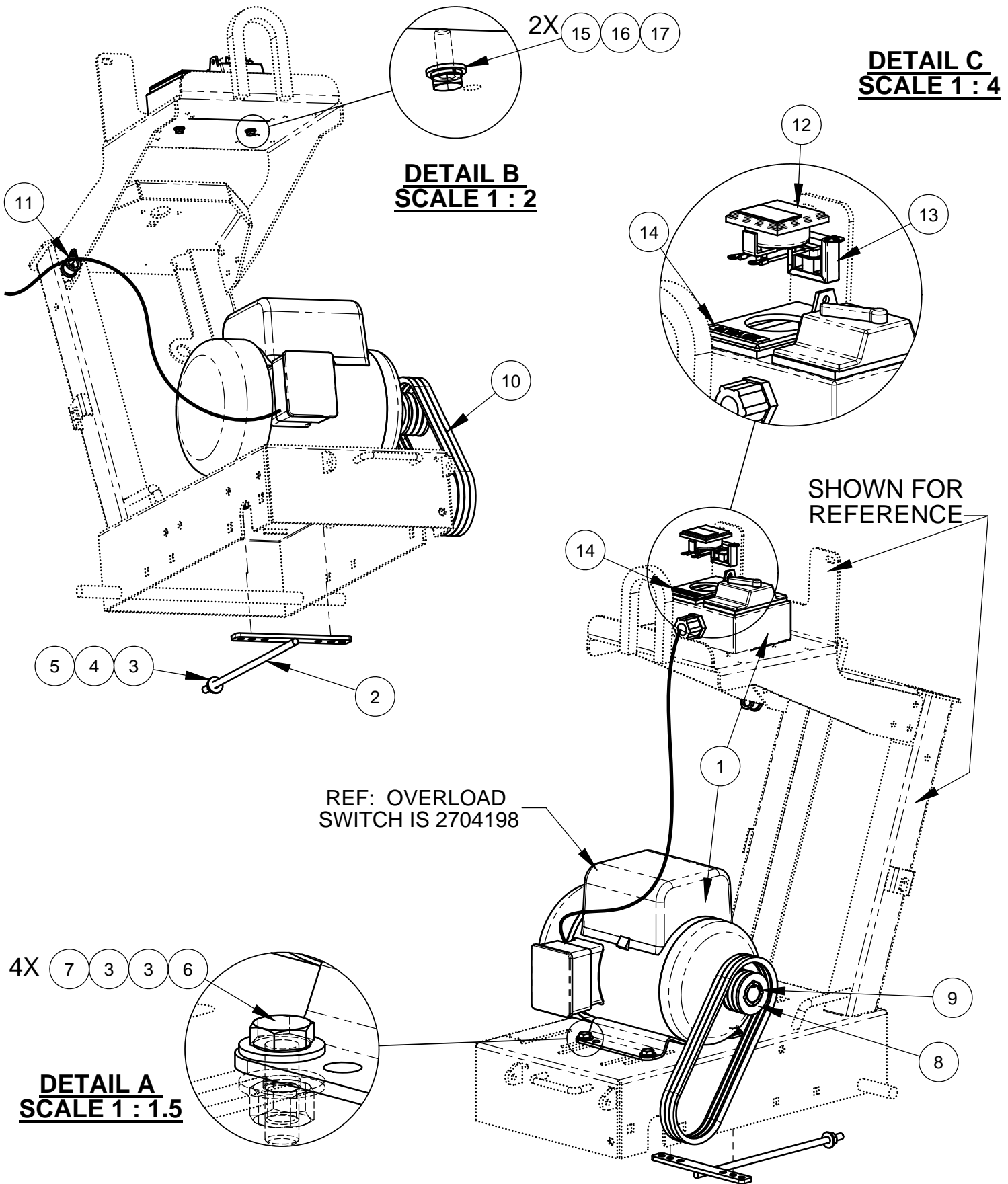

6041347 CC1300 XL ELECTRIC MOTOR OPTION, 5HP, 230V, 1-PHASE

ITEM	PART NO.	QTY.	DESCRIPTION
1	2600278	1	Motor, 5HP, 230V, 1 Ph, W/Switch Box
2	6040261	1	Belt Adjustment Weldment
3	2900473	9	Flat Washer, 3/8" USS
4	2900321	1	Lock Washer, M10 Split
5	2900325	1	Hex Nut, M10-1.5
6	2900223	4	Cap Screw, Hex Hd., M10-1.5 x 30mm
7	2900304	4	Lock Nut, M10-1.5 Nylon Insert
8	2500022	1	Sheave, 2.65 - 3 Groove
9	2500027	1	Taper Bushing, 1-1/8" W/ Setscrews & Key
10	2500380	3	V-Belt, 3VX300
11	2801151	1	Hose Clamp, 3/4" x 3/4" Wide
12	2800253	1	Ampmeter, 0-40 Amp, AC
13	2800085	1	AC Current Transformer
14	1800810	1	Voltage Label, 230V
15	2900009	2	Flat Washer, 1/4" SAE
16	2900024	2	Lock Washer, 1/4" Split
17	2900144	2	Cap Screw, Hex Hd., 1/4-20 x 3/4"
18	6048181	1	Frame Weldment (Regular Cut)
19	6030318	1	Lift Bar Assembly

WITH UPCUT FRAME,6048269, REVERSE MOTOR MOUNTING.

6043436 CC1300XL ELECTRIC MOTOR OPTION, 5HP, 230V, 3-PHASE

DETAIL B
SCALE 1 : 4

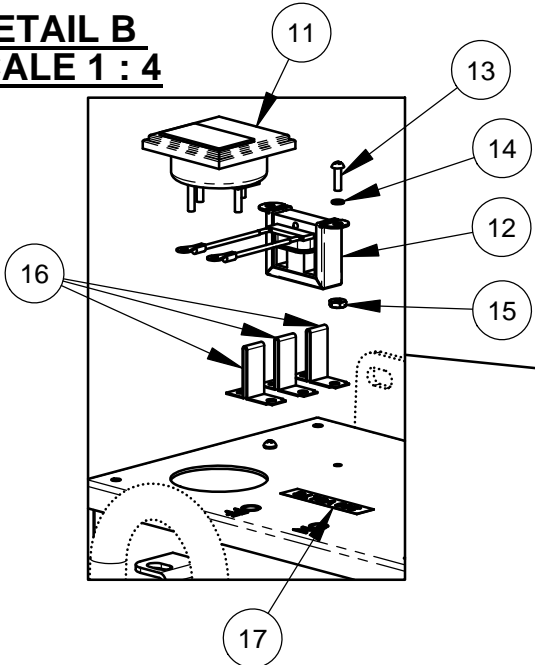

SHOWN FOR REFERENCE

DETAIL C
SCALE 1 : 1.5

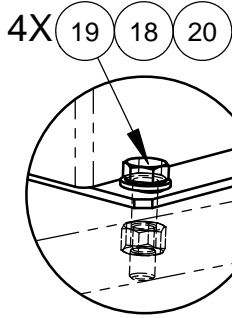

4X

- 7
- 3
- 3
- 6

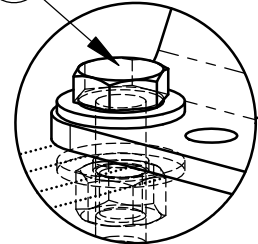

DETAIL A
SCALE 1 : 1.5

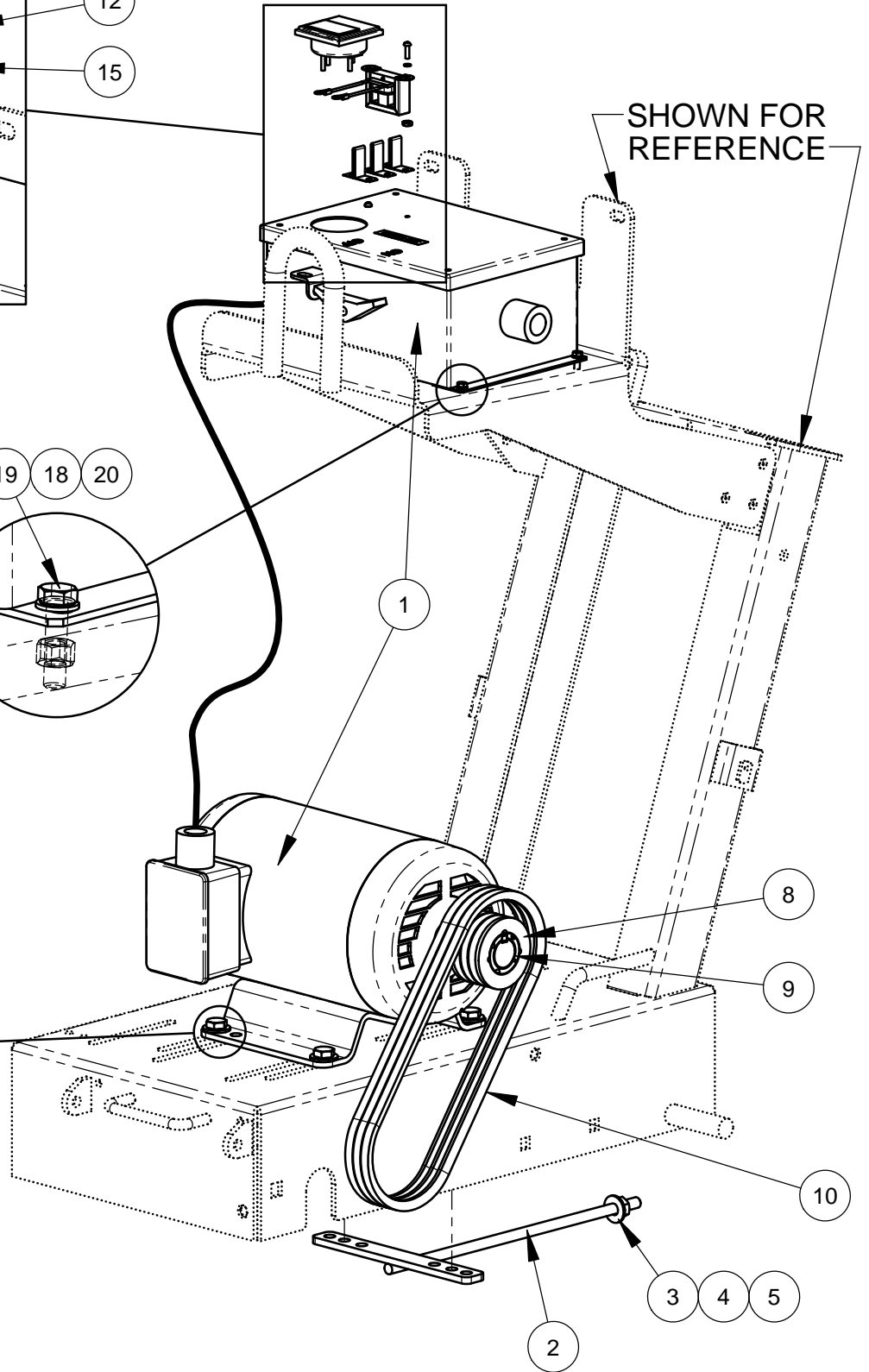

6043436 CC1300XL ELECTRIC MOTOR OPTION, 5HP, 230V, 3-PHASE

ITEM	PART NO.	QTY.	DESCRIPTION
1	6000032	1	5HP, 3 Ph, 230V Motor W/Starter Box
2	6040261	1	Belt Adjustment Weldment
3	2900473	9	Flat Washer, 3/8" USS
4	2900321	1	Lock Washer, M10 Split
5	2900325	1	Hex Nut, M10-1.5
6	2900223	4	Cap Screw, Hex Hd., M10-1.5 x 30mm
7	2900304	4	Lock Nut, M10-1.5 Nylon Insert
8	2500022	1	Sheave, 2.65 - 3 Groove
9	2500027	1	Taper Bushing, 1-1/8" W/ Setscrews & Key
10	2500380	3	V-Belt, 3VX300
11	2800253	1	Amp Meter w/ Bracket, 0-40 AC
12	2800085	1	AC Current Transformer
13	2900090	2	Machine Screw, Rd. Hd., #6-32 x 1/2"
14	2900092	2	Lock Washer, #6 Split
15	2900091	2	Hex Nut, #6-32
16	2800551	3	Heater, 12.1-12.7 Amp
17	1800810	1	Voltage Label, 230V
18	2900926	4	Flat Washer, M5
19	2900309	4	Cap Screw, Hex Hd., M5-0.8 x 20mm
20	2900301	4	Lock Nut, M5-0.8 Nylon Insert
21	6048181	1	Frame Weldment (Regular Cut)
22	6030318	1	Lift Bar Assembly

6043437 CC1300XL ELECTRIC MOTOR OPTION, 5HP, 460V, 3-PHASE

DETAIL B
SCALE 1 : 4

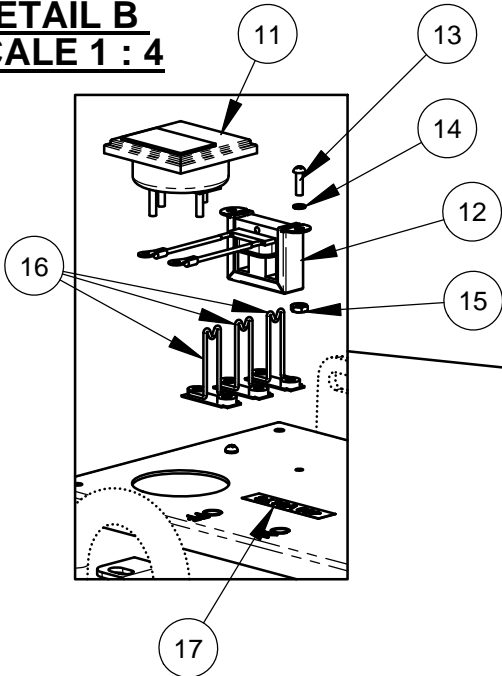

SHOWN FOR REFERENCE

DETAIL C
SCALE 1 : 1.5

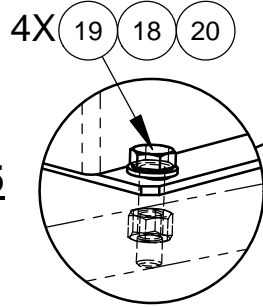

4X

- 7
- 3
- 3
- 6

DETAIL A
SCALE 1 : 1.5

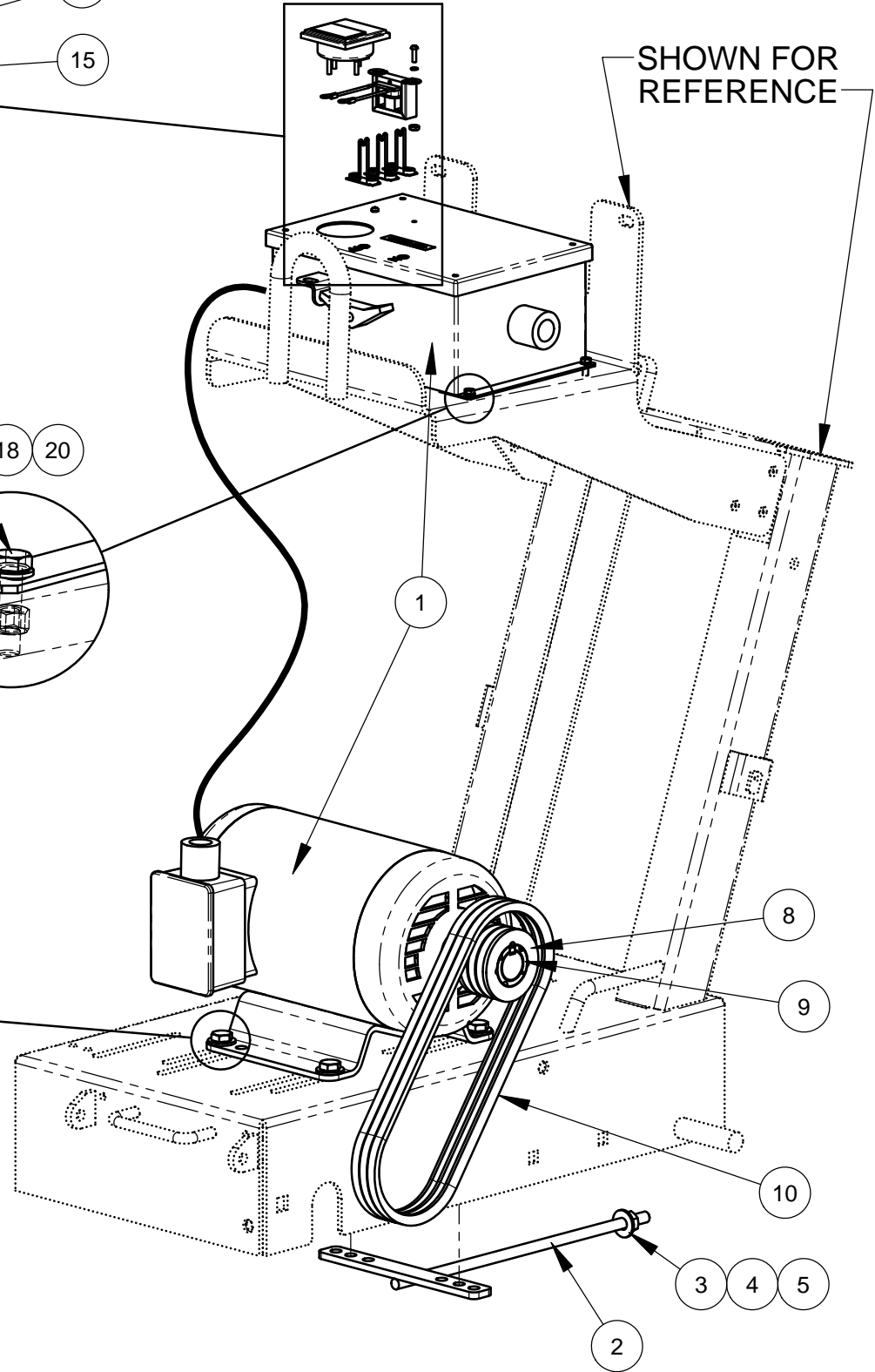
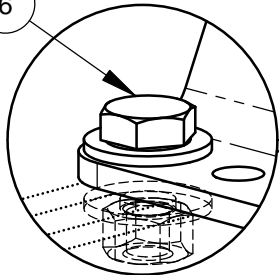

6043437 CC1300XL ELECTRIC MOTOR OPTION, 5HP, 460V, 3-PHASE

ITEM	PART NO.	QTY.	DESCRIPTION
1	6000033	1	5HP, 3Ph, 460V Motor W/ Starter Box
2	6040261	1	Belt Adjustment Weldment
3	2900473	9	Flat Washer, 3/8" USS
4	2900321	1	Lock Washer, M10 Split
5	2900325	1	Hex Nut, M10-1.5
6	2900223	4	Cap Screw, Hex Hd., M10-1.5 x 30mm
7	2900304	4	Lock Nut, M10-1.5 Nylon Insert
8	2500022	1	Sheave, 2.65 - 3 Groove
9	2500027	1	Taper Bushing, 1-1/8" W/ Setscrews & Key
10	2500380	3	V-Belt, 3VX300
11	2800253	1	Amp Meter w/ Bracket, 0-40 AC
12	2800085	1	AC Current Transformer
13	2900090	2	Machine Screw, Rd. Hd., #6-32 x 1/2"
14	2900092	2	Lock Washer, #6 Split
15	2900091	2	Hex Nut, #6-32
16	2800536	3	Heater, 6.3 - 6.9 Amp
17	1800811	1	Voltage Label, 460V
18	2900926	4	Flat Washer, M5
19	2900309	4	Cap Screw, Hex Hd., M5-0.8 x 20mm
20	2900301	4	Lock Nut, M5-0.8 Nylon Insert
21	6048181	1	Frame Weldment (Regular Cut)
22	6030318	1	Lift Bar Assembly

6043400 CC1300 XL ELECTRIC MOTOR OPTION, 10HP, 230V, 3-PHASE

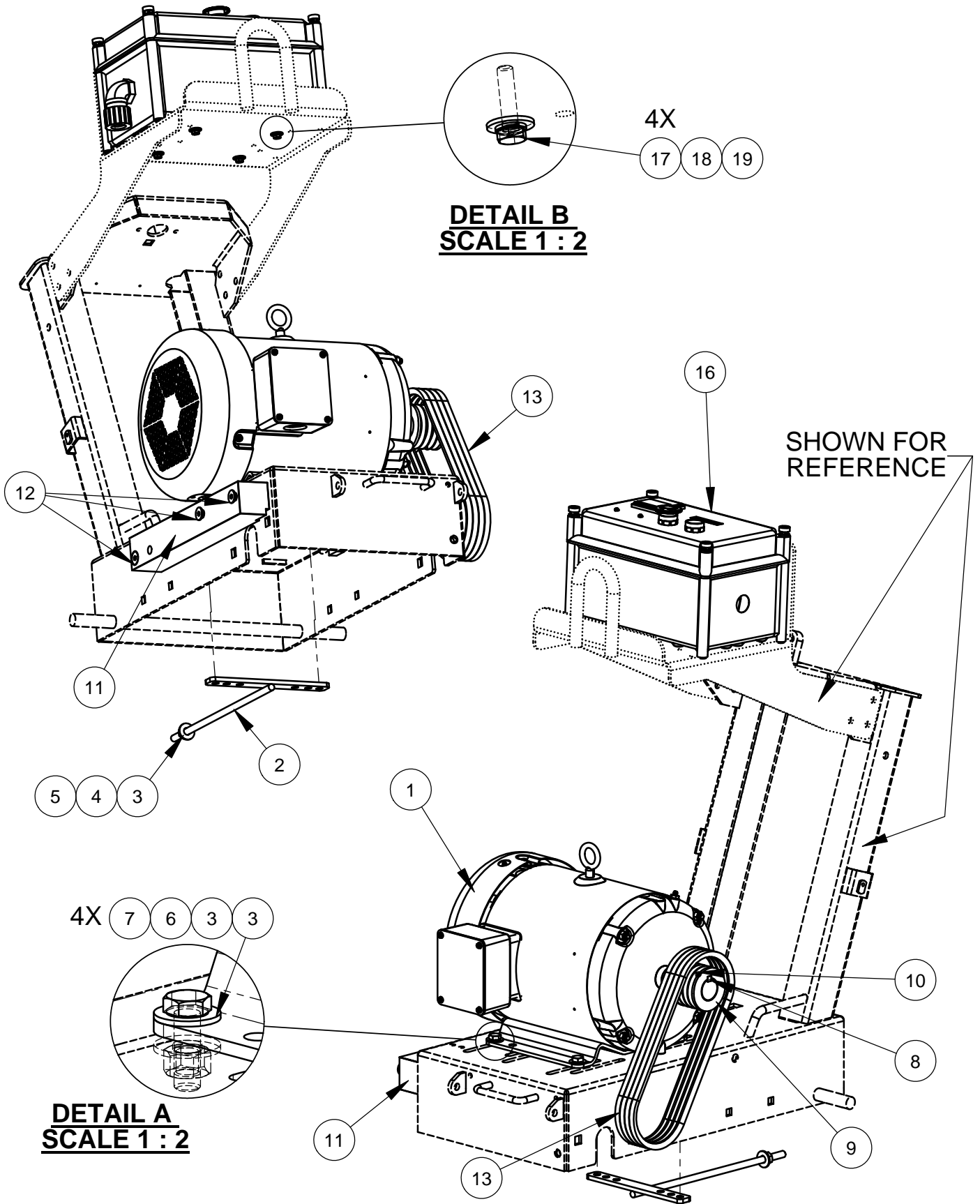

6043400 CC1300 XL ELECTRIC MOTOR OPTION, 10HP, 230V, 3-PHASE

ITEM NO.	PART NUMBER	QTY.	DESCRIPTION
1	2600187	1	Motor, 10hp 3 Phase Baldor
2	6040261	1	Belt Adjustment Weldment
3	2900473	9	Flat Washer, 3/8" USS
4	2900321	1	Lock Washer, M10 Split
5	2900325	1	Hex Nut, M10-1.5
6	2900223	4	Cap Screw, Hex Hd., M10-1.5 x 30mm
7	2900304	4	Lock Nut, M10-1.5 Nylon Insert
8	6048046	1	Key, 5/16" Sq. x 1-1/2"
9	6048897	1	Sheave, 2.65 - 4 Groove
10	2900036	1	Set Screw, Soc. Hd., 5/16-18 x 1/4"
11	6048319	1	Blade Guard Spacer
12	2900908	3	Cap Screw, Flat Hd., M10-1.5 x 80mm
13	2500380	4	V-Belt, 3VX300
14	6048181	1	Frame Weldment (Regular Cut)
15	6030318	1	Lift Bar Assembly
16	6004894	1	Starter Box Assembly, 3-Phase, 220-240V
17	2900311	4	Cap Screw, Hex Hd., M6-1.0 x 25mm
18	2900765	4	Lock Washer, M6 Split
19	2901359	4	Fender Washer, M6

6043430 CC1300 XL ELECTRIC MOTOR OPTION, 10HP, 460V, 3-PHASE

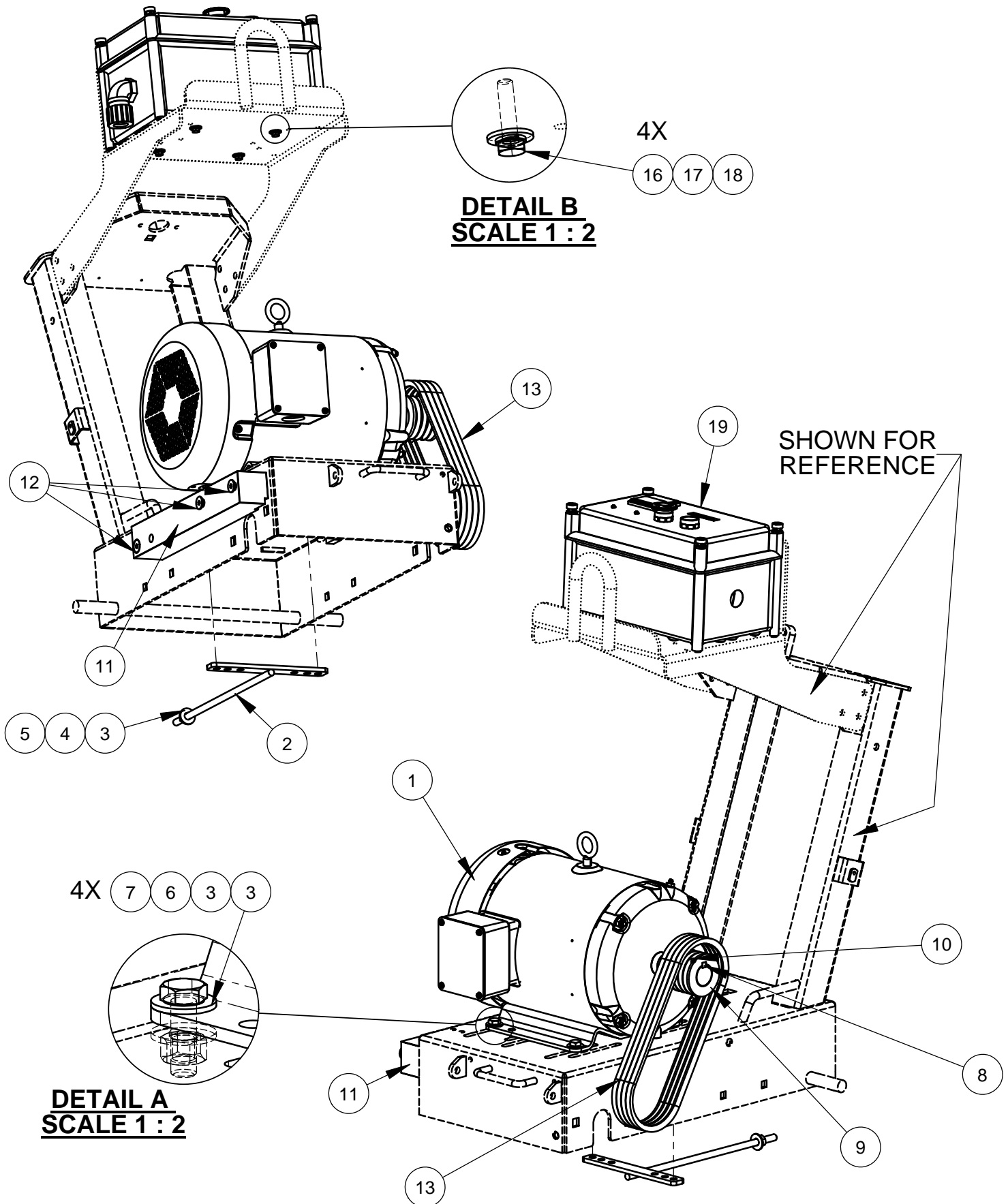

6043430 CC1300 XL ELECTRIC MOTOR OPTION, 10HP, 460V, 3-PHASE

ITEM NO.	PART NUMBER	QTY.	DESCRIPTION
1	2600187	1	Motor, 10hp 3 Phase Baldor
2	6040261	1	Belt Adjustment Weldment
3	2900473	9	Flat Washer, 3/8" USS
4	2900321	1	Lock Washer, M10 Split
5	2900325	1	Hex Nut, M10-1.5
6	2900223	4	Cap Screw, Hex Hd., M10-1.5 x 30mm
7	2900304	4	Lock Nut, M10-1.5 Nylon Insert
8	6048046	1	Key, 5/16" Sq. x 1-1/2"
9	6048897	1	Sheave, 2.65 - 4 Groove
10	2900036	1	Set Screw, Soc. Hd., 5/16-18 x 1/4"
11	6048319	1	Blade Guard Spacer
12	2900908	3	Cap Screw, Flat Hd., M10-1.5 x 80mm
13	2500380	4	V-Belt, 3VX300
14	6048181	1	Frame Weldment (Regular Cut)
15	6030318	1	Lift Bar Assembly
16	2900311	4	Cap Screw, Hex Hd., M6-1.0 x 25mm
17	2900765	4	Lock Washer, M6 Split
18	2901359	4	Fender Washer, M6
19	6004898	1	Starter Box Assembly, 3-Phase, 415-480V

6043432 CC1300 XL ELECTRIC MOTOR OPTION, 10HP, 575V, 3-PHASE

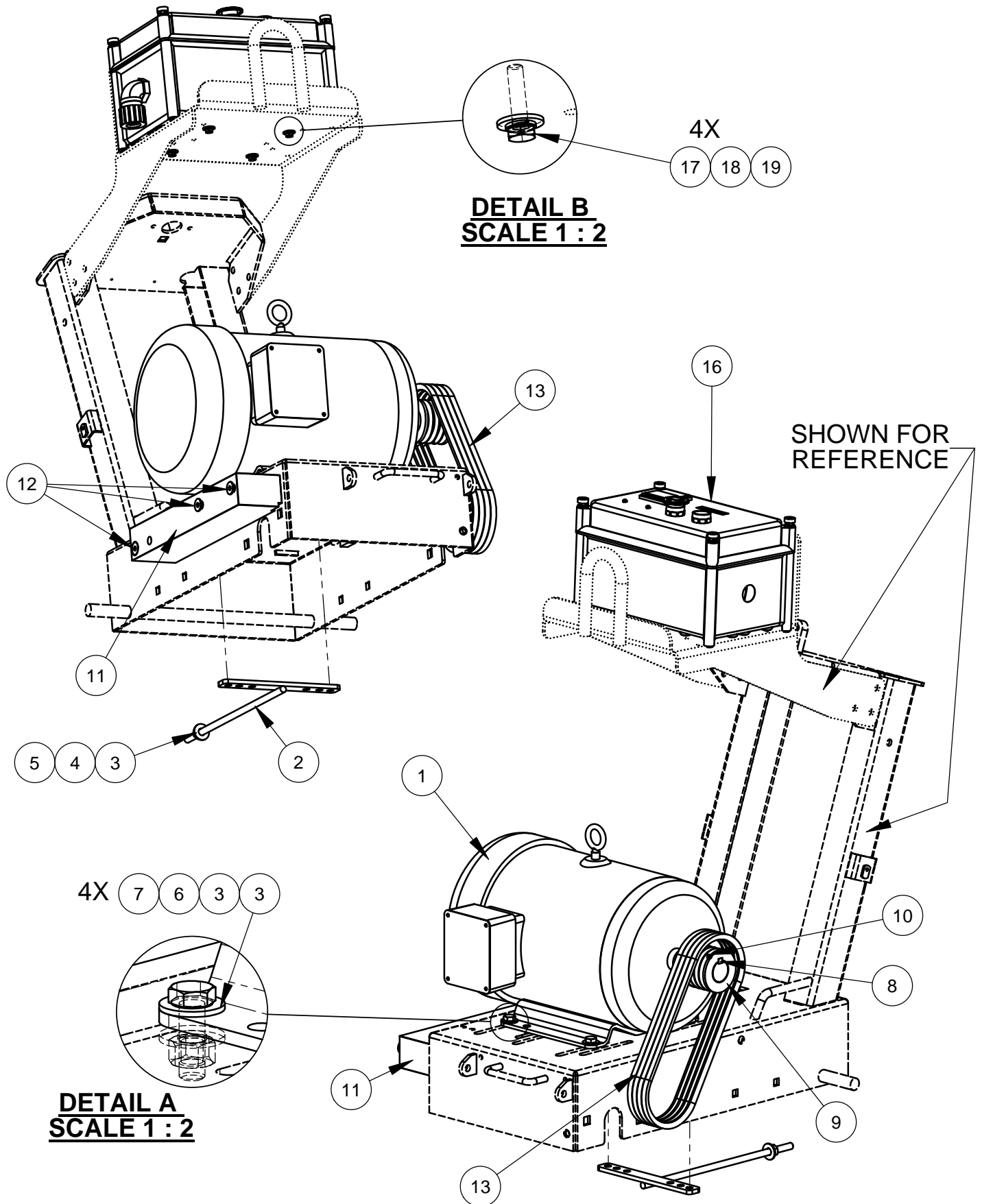

6043432 CC1300 XL ELECTRIC MOTOR OPTION, 10HP, 575V, 3-PHASE

ITEM NO.	PART NUMBER	QTY.	DESCRIPTION
1	2600703	1	Motor, 10 HP, 575V, 3 PH. Baldor
2	6040261	1	Belt Adjustment Weldment
3	2900473	9	Flat Washer, 3/8" USS
4	2900321	1	Lock Washer, M10 Split
5	2900325	1	Hex Nut, M10-1.5
6	2900223	4	Cap Screw, Hex Hd., M10-1.5 x 30mm
7	2900304	4	Lock Nut, M10-1.5 Nylon Insert
8	6048046	1	Key, 5/16" Sq. x 1-1/2"
9	6048897	1	Sheave, 2.65 - 4 Groove
10	2900036	1	Set Screw, Soc. Hd., 5/16-18 x 1/4"
11	6047308	1	Blade Guard Spacer, 3"
12	2901507	3	Cap Screw, Flat Hd., M10-1.5 x 100mm
13	2500380	4	V-Belt, 3VX300
14	6048181	1	Frame Weldment (Regular Cut)
15	6030318	1	Lift Bar Assembly
16	6004901	1	Starter Box Assembly, 3-Phase, 550-600V
17	2900311	4	Cap Screw, Hex Hd., M6-1.0 x 25mm
18	2900765	4	Lock Washer, M6 Split
19	2901359	4	Fender Washer, M6

STARTER BOX ASSEMBLY, 3-PHASE, 220-240V
#6004894

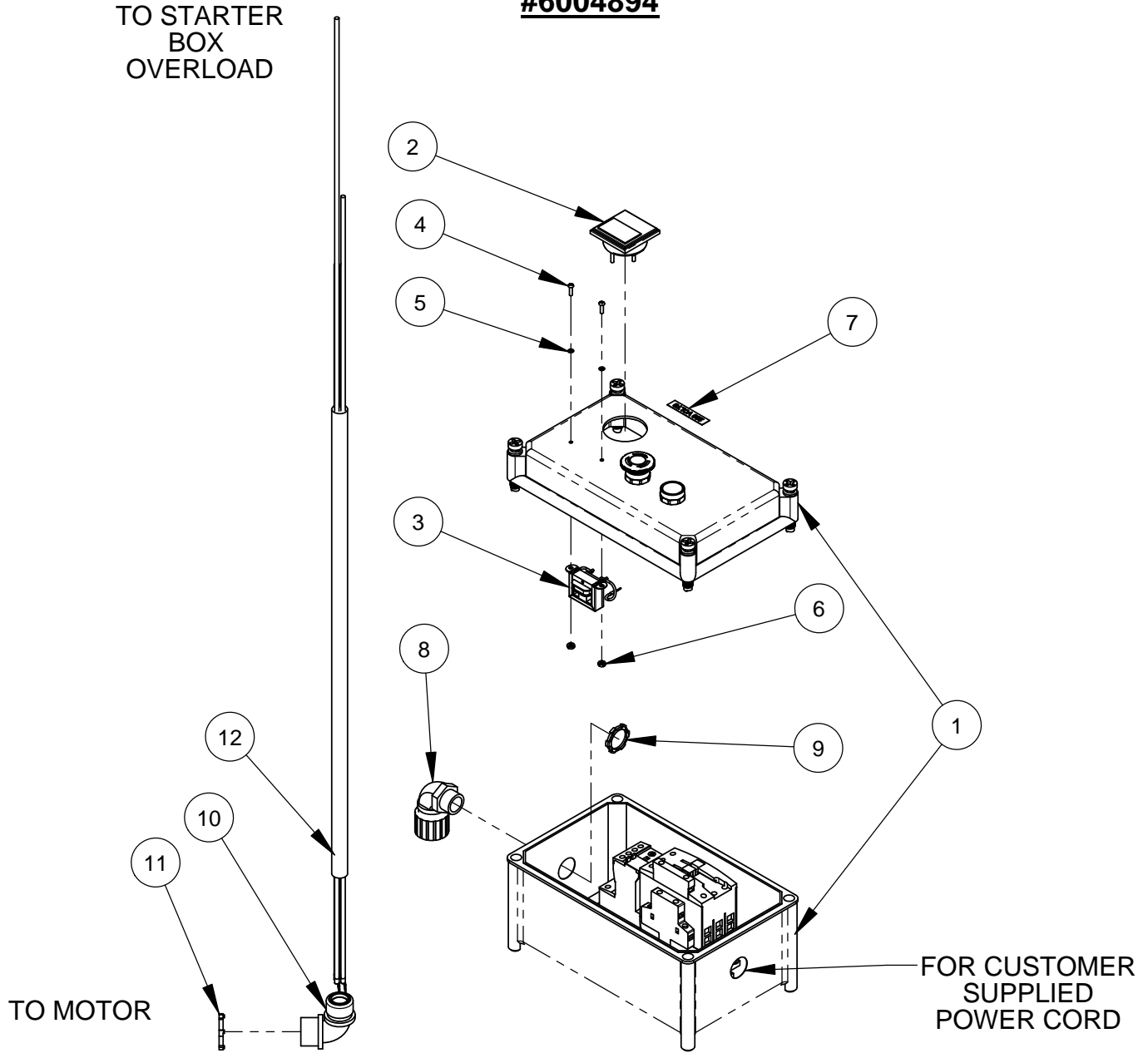

ITEM	PART NO.	QTY.	DESCRIPTION
1	2804008	1	Starter Box, 220-240V
2	2800253	1	Amp Meter w/ Bracket, 0-40 AC
3	2800085	1	AC Current Transformer
4	2900090	2	Machine Screw, Rd. Hd., #6-32 x 1/2"
5	2900092	2	Lock Washer, #6 Split
6	2900091	2	Hex Nut, #6-32
7	1800810	1	Voltage Label, 230V
8	2802052	1	Cord Connector, 3/4" Thd., .63-75" Cord, 90 Deg.
9	2801304	1	Lock Nut, 3/4"
10	2800695	1	Cord Grip, 5/8-3/4", 90 Deg.
11	2800193	1	Lock Nut, 1"
12	6040423	1	Cable Assy., 10 Ga., 4 Wire x 54"

STARTER BOX ASSEMBLY, 3-PHASE, 415-480V
#6004898

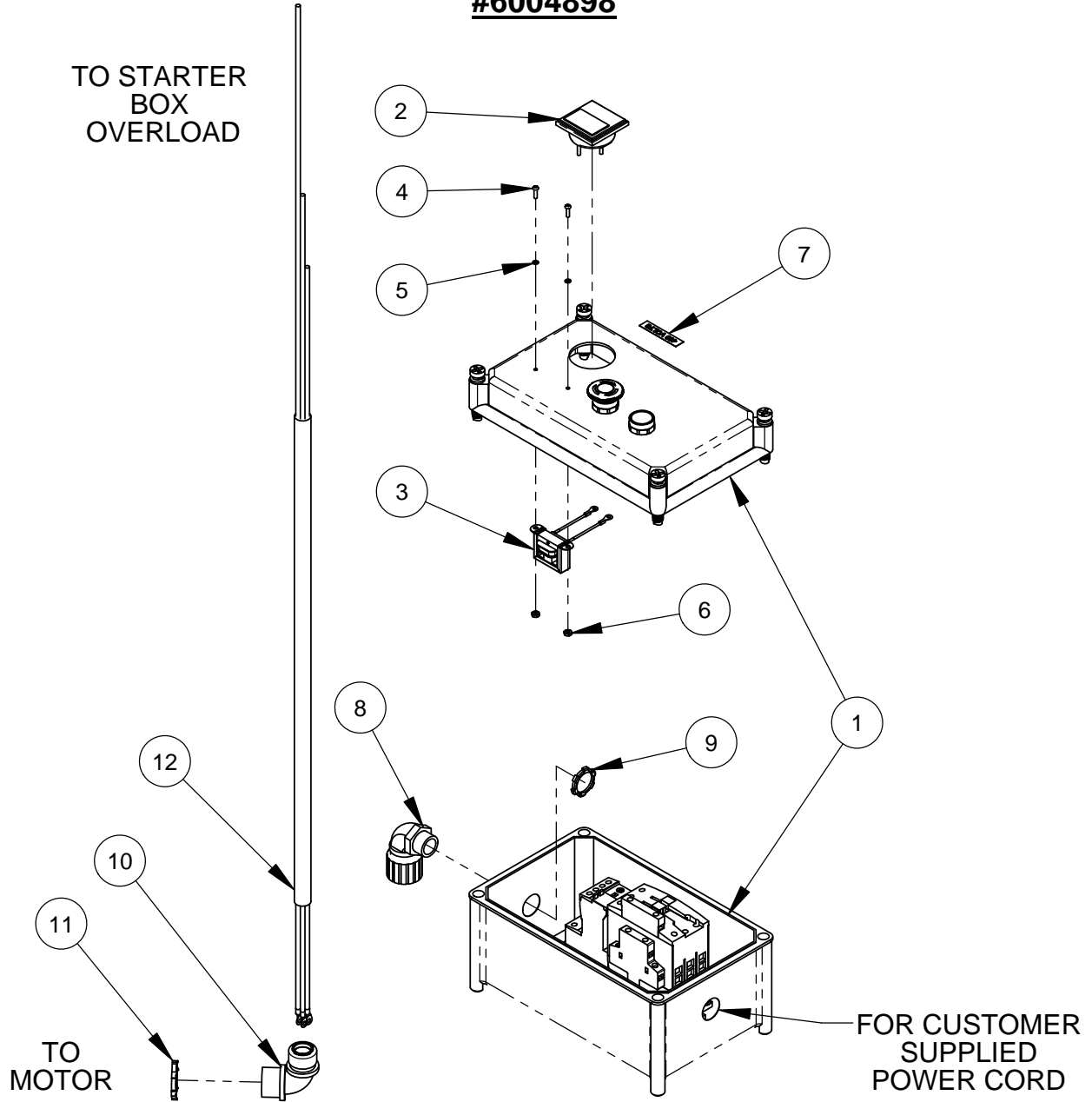

ITEM	PART NO.	QTY.	DESCRIPTION
1	2804007	1	Starter Box, 415-480V
2	2800252	1	Amp Meter, 0-20 AC
3	2800085	1	AC Current Transformer
4	2900090	2	Machine Screw, Rd. Hd., #6-32 x 1/2"
5	2900092	2	Lock Washer, #6 Split
6	2900091	2	Hex Nut, #6-32
7	1800811	1	Voltage Label, 460V
8	2802052	1	Cord Connector, 3/4" Thd., .63-75" Cord, 90 Deg.
9	2801304	1	Lock Nut, 3/4"
10	2800695	1	Cord Grip, 5/8-3/4", 90 Deg.
11	2800193	1	Lock Nut, 1"
12	6040423	1	Cable Assy., 10 Ga., 4 Wire x 54"

Intentionally Blank

STARTERBOX ASSEMBLY, 3-PHASE, 550-600V
#6004901

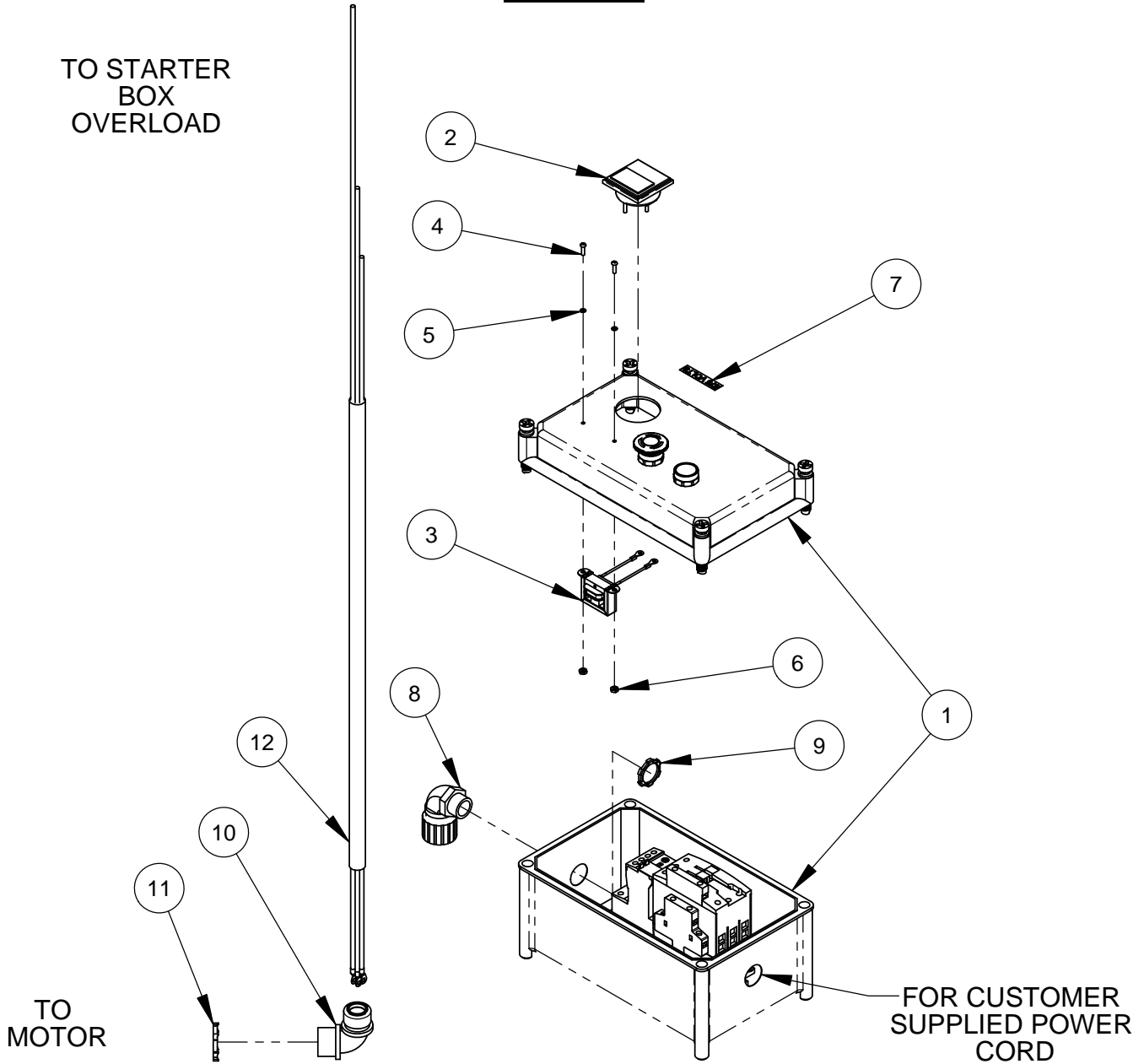

ITEM	PART NO.	QTY.	DESCRIPTION
1	2802061	1	Starter Box, 550-600V
2	2800252	1	Amp Meter, 0-20 AC
3	2800085	1	AC Current Transformer
4	2900090	2	Machine Screw, Rd. Hd., #6-32 x 1/2"
5	2900092	2	Lock Washer, #6 Split
6	2900091	2	Hex Nut, #6-32
7	1800812	1	Voltage Label, 575V
8	2802052	1	Cord Connector, 3/4" Thd., .63-75" Cord, 90 Deg.
9	2801304	1	Lock Nut, 3/4"
10	2800695	1	Cord Grip, 5/8-3/4", 90 Deg.
11	2800193	1	Lock Nut, 1"
12	6040423	1	Cable Assy., 10 Ga., 4 Wire x 54"

2804008 STARTER BOX, 220-240 VOLT

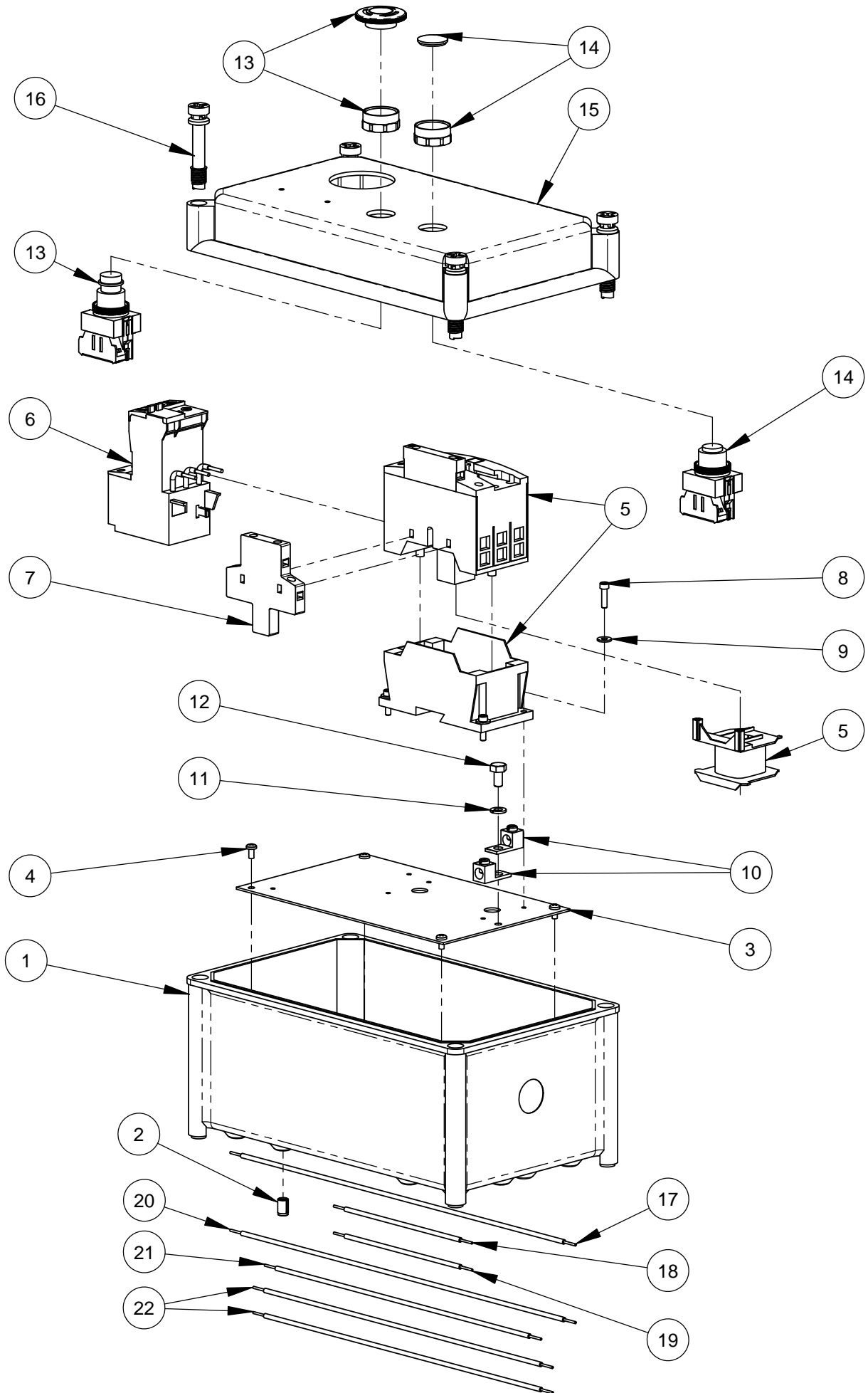

2804008 STARTER BOX, 220-240 VOLT

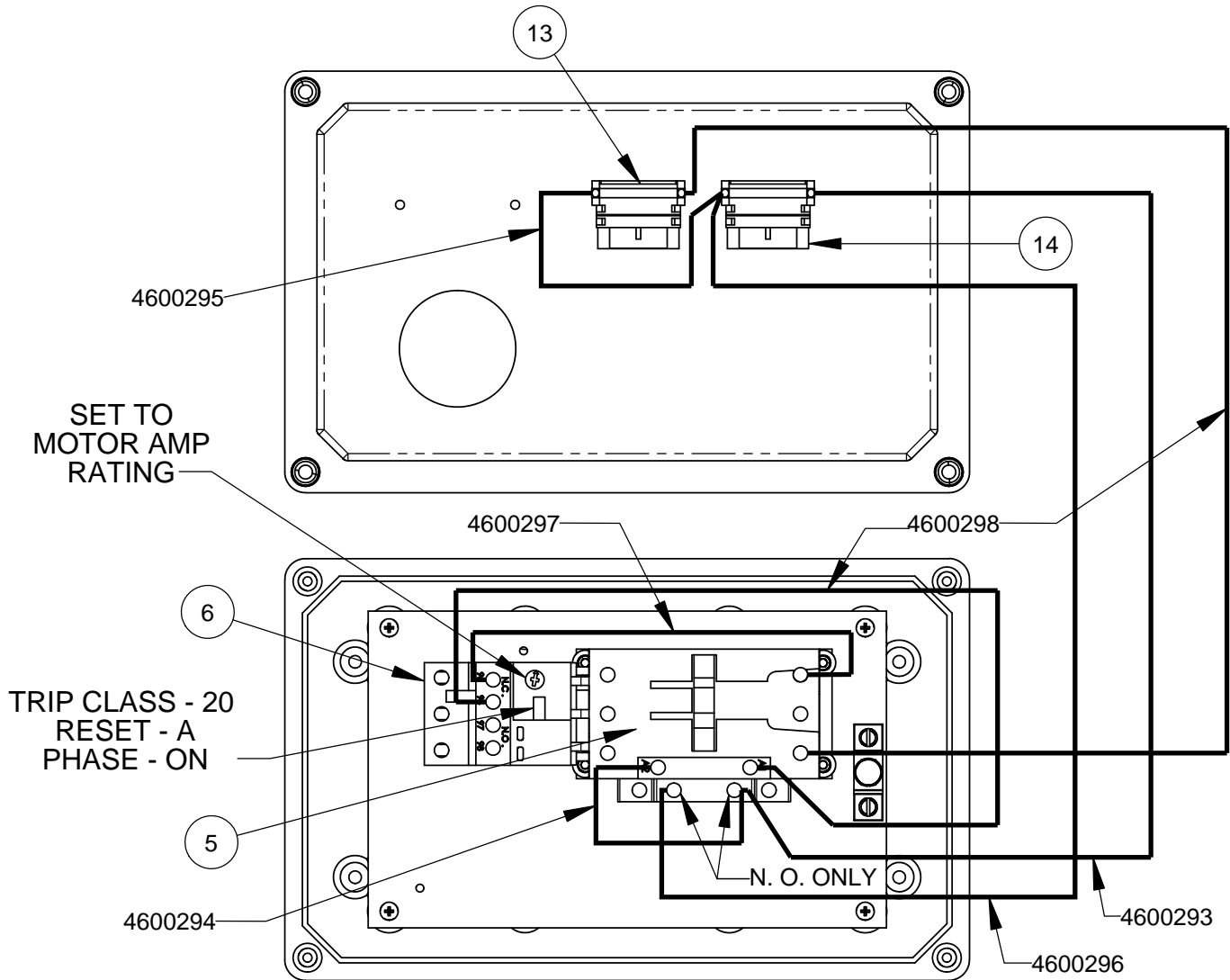

ITEM	PART NO.	QTY.	DESCRIPTION	ITEM	PART NO.	QTY.	DESCRIPTION
1	6040300D	1	Starter Box Base	12	2901891	1	Cap Screw, Hex Hd., 1/4-28 x 1/2"
2	2901588	4	M6-1.0 Threaded Insert	13	2801636	1	E-Stop Switch, 600V, NC
3	6040598	1	Sub-plate	14	2801639	1	Pushbutton, N.O., 600V
4	2900676	4	Machine Screw, Pan Hd., M4-0.7 x 8mm	15	6048293	1	Starter Box Cover
5	2801704	1	Contactor, 220-240V (includes coil)	16	2701414	4	Fastener, Electrical Box Top
	2801265	1	Replacement Coil, 220-240V	17	4600293	1	Wire, 14 Gage, Yellow, 15"
6	2801699	1	Overload Relay, 9-45 AMP	18	4600294	1	Wire, 14 Gage, Yellow, 6"
7	2801676	1	Auxiliary Contacts, 1NO-NC	19	4600295	1	Wire, 14 Gage, Black, 6"
8	2901827	4	Cap Screw, Soc. Hd., #8-32 x 5/8"	20	4600296	1	Wire, 14 Gage, Black, 15"
9	2901437	4	Flat Washer, #10	21	4600297	1	Wire, 14 Gage, Red, 12"
10	2800315	2	Grounding Lug	22	4600298	2	Wire, 14 Gage, Red, 13"
11	2900024	1	Lock Washer, 1/4" Split				

2804007 STARTER BOX, 415-480 VOLT

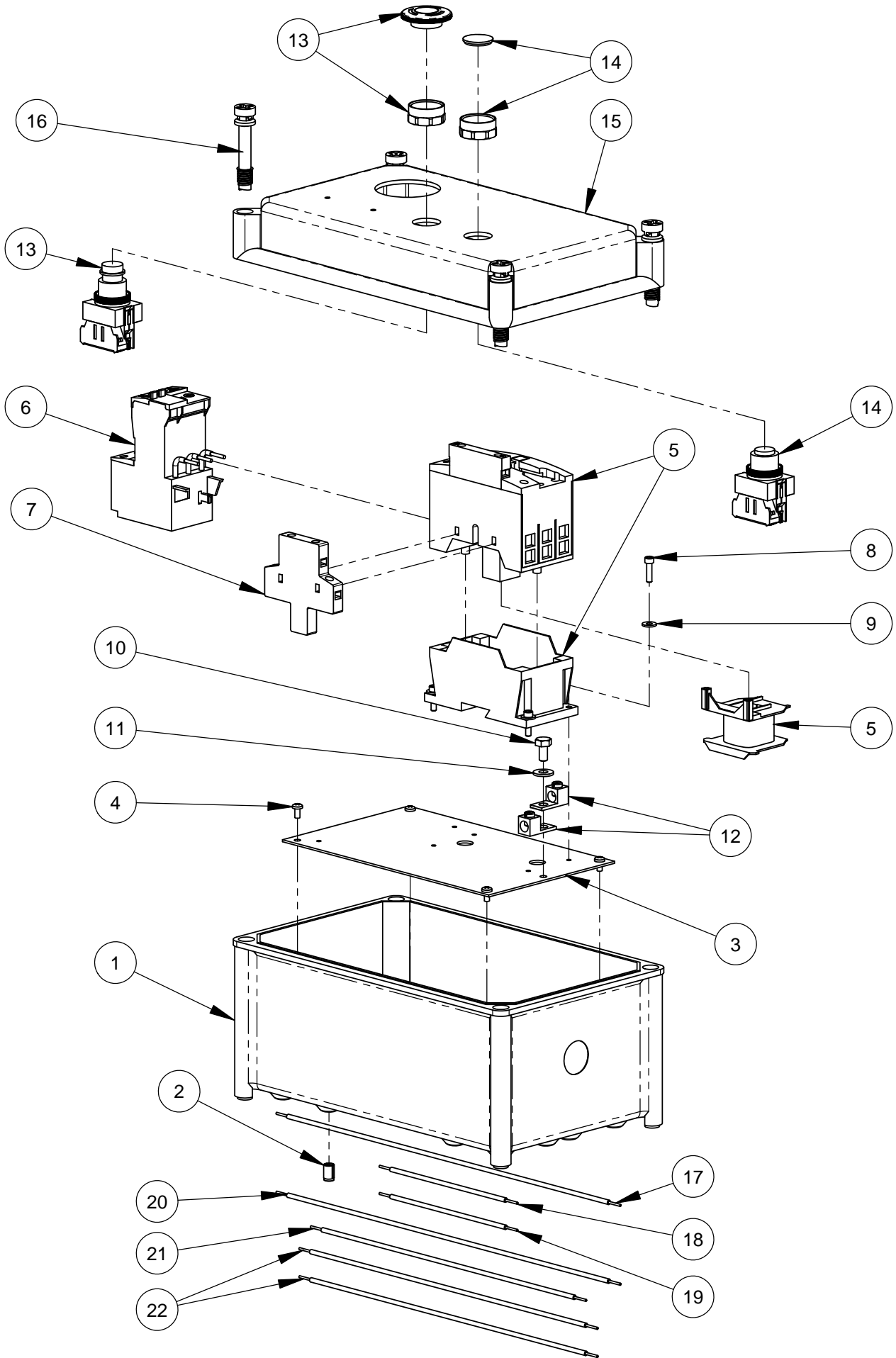

2804007 STARTER BOX, 415-480 VOLT

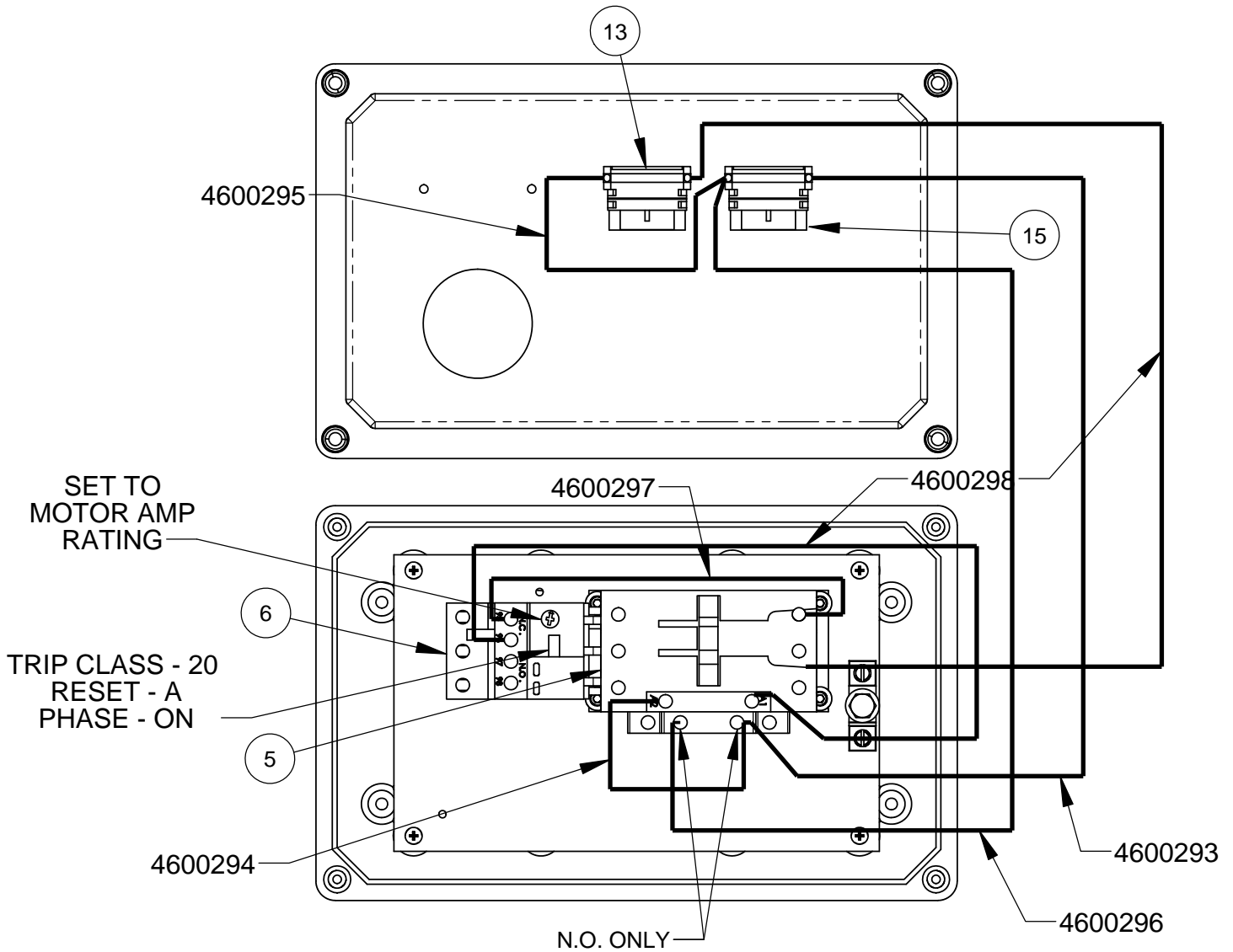

ITEM	PART NO.	QTY.	DESCRIPTION	ITEM	PART NO.	QTY.	DESCRIPTION
1	6040300D	1	Starter Box Base	12	2800315	2	Grounding Lug
2	2901588	4	M6-1.0 Threaded Insert	13	2801636	1	E-Stop Switch, 600V, NC
3	6040598	1	Sub-plate	14	2801639	1	Pushbutton, N.O., 600V
4	2900676	4	Machine Screw, Pan Hd., M4-0.7 x 8mm	15	6048293	1	Starter Box Cover
5	2801707	1	Contactor, 415-480V (Includes Coil)	16	2701414	4	Fastener, Electrical Box Top
	2801266	1	Replacement Coil, 415-480V	17	4600293	1	Wire, 14 Gage, Yellow, 15"
6	2801699	1	Overload Relay, 9-45 AMP	18	4600294	1	Wire, 14 Gage, Yellow, 6"
7	2801676	1	Auxiliary Contacts, 1NO-NC	19	4600295	1	Wire, 14 Gage, Black, 6"
8	2901827	4	Cap Screw, Soc. Hd., #8-32 x 5/8"	20	4600296	1	Wire, 14 Gage, Black, 15"
9	2901437	4	Flat Washer, #10	21	4600297	1	Wire, 14 Gage, Red, 12"
10	2901891	1	Cap Screw, Hex Hd., 1/4-28 x 1/2"	22	4600298	2	Wire, 14 Gage, Red, 13"
11	2900009	1	Flat Washer, 1/4" SAE				

2802061 STARTER BOX, 550-600 VOLT

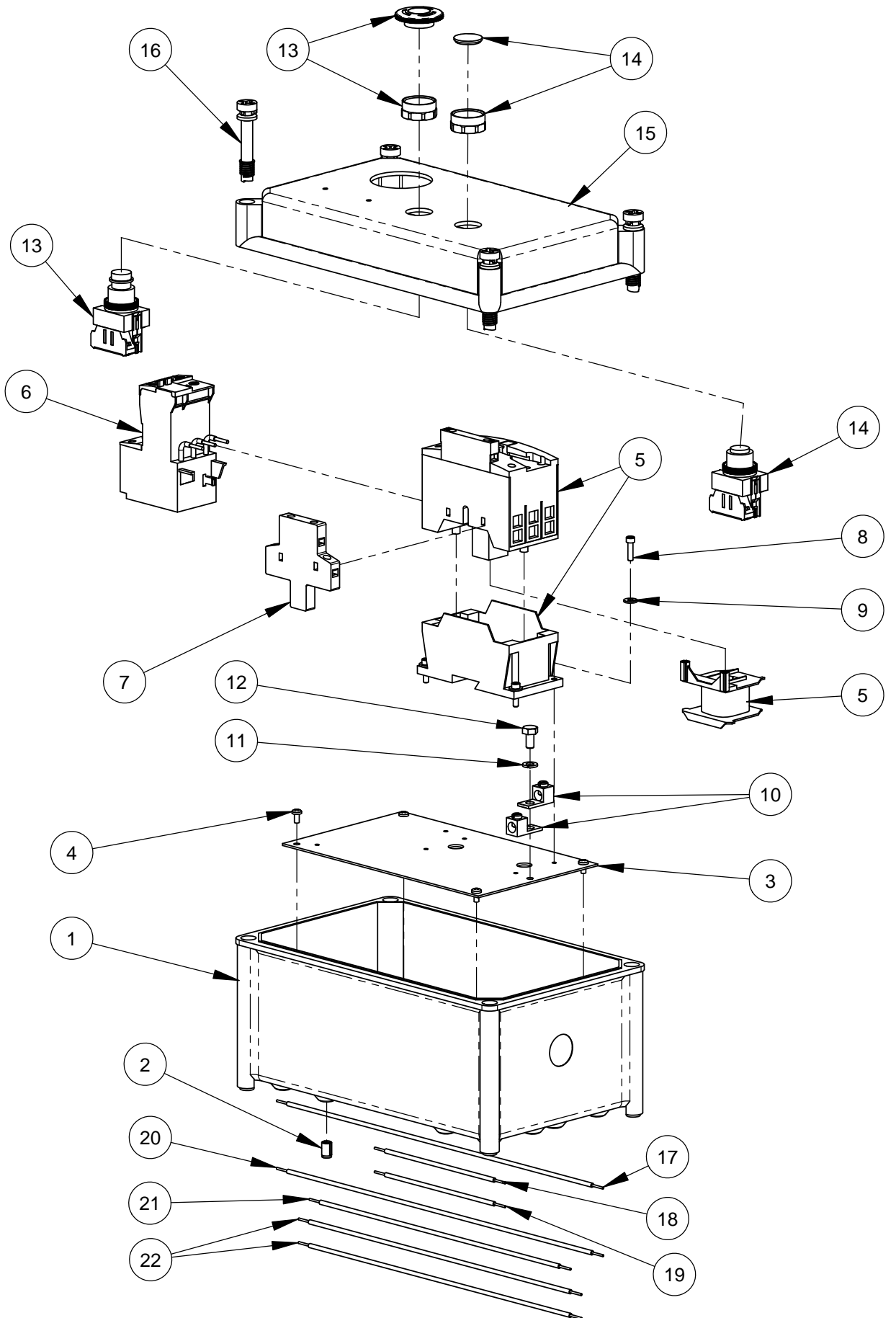

2802061 STARTER BOX, 550-600 VOLT

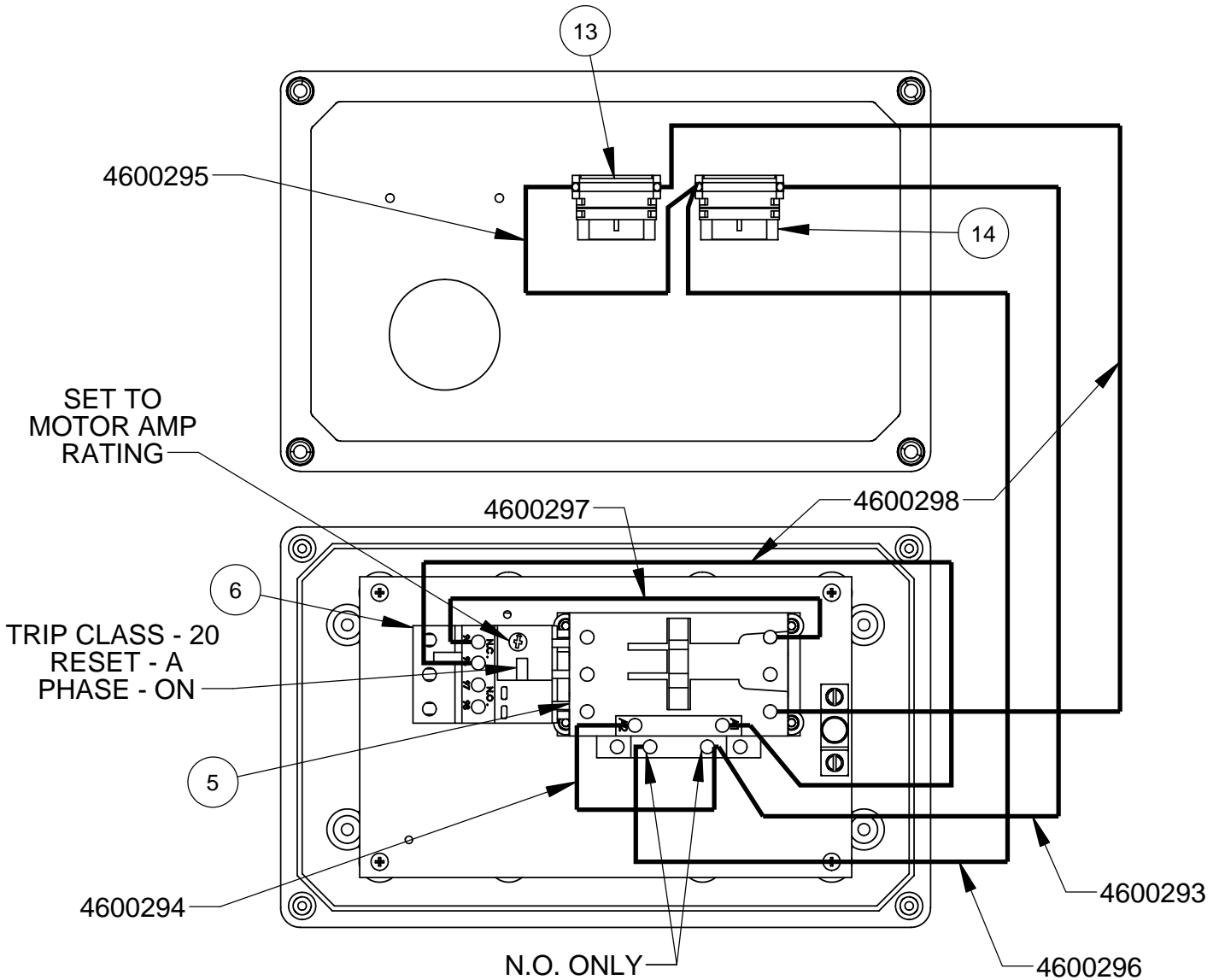

ITEM	PART NO.	QTY.	DESCRIPTION	ITEM	PART NO.	QTY.	DESCRIPTION
1	6040300D	1	Starter Box Base	11	2900024	1	Lock Washer, 1/4" Split
2	2901588	4	M6-1.0 Threaded Insert	12	2901891	1	Cap Screw, Hex Hd., 1/4-28 x 1/2"
3	6040598	1	Sub-plate	13	2801636	1	E-Stop Switch, 600V, NC
4	2900676	4	Machine Screw, Pan Hd., M4-0.7 x 8mm	14	2801639	1	Pushbutton, N.O., 600V
5	2801709	1	Contactor, 550-600V (includes coil)	15	6048293	1	Starter Box Cover
	2801267	1	Replacement Coil, 550-600V	16	2701414	4	Fastener, Electrical Box Top
6	2801699	1	Overload Relay, 9-45 AMP	17	4600293	1	Wire, 14 Gage, Yellow, 15"
7	2801676	1	Auxiliary Contacts, 1NO-NC	18	4600294	1	Wire, 14 Gage, Yellow, 6"
8	2901827	4	Cap Screw, Soc. Hd., #8-32 x 5/8"	19	4600295	1	Wire, 14 Gage, Black, 6"
9	2901437	4	Flat Washer, #10	20	4600296	1	Wire, 14 Gage, Black, 15"
10	2800315	2	Grounding Lug	21	4600297	1	Wire, 14 Gage, Red, 12"
				22	4600298	2	Wire, 14 Gage, Red, 13"

6048233 HYDRAULIC MOTOR OPTION, 1.16CI

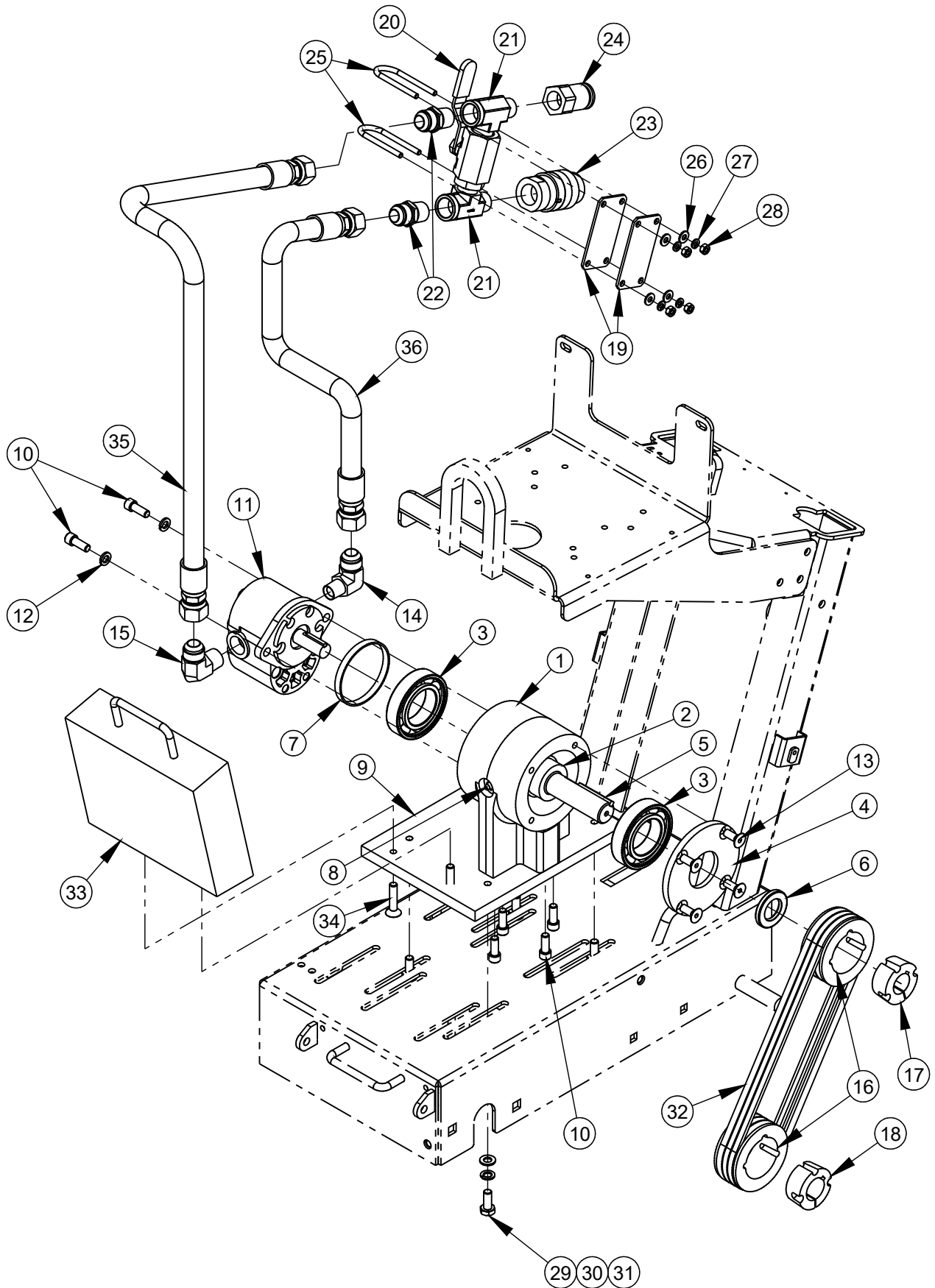

6048233 HYDRAULIC MOTOR OPTION, 1.16CI

ITEM	PART NO.	QTY.	DESCRIPTION
1	6048115	1	Pillow Block
2	6048116	1	Hydraulic Spindle Shaft
3	2500686	2	Bearing, 50mm x 90mm x 20mm
4	6048117	1	Seal Plate
5	6048134	1	Key, 1/4" Sq. x 2-1/4"
6	3200004	1	Seal, 1-1/8" x 2" x 1/4"
7	4699901	1	Shim For Hydraulic Spindle Shaft
8	2900062	1	Grease Fitting, 1/8" NPT
9	6048872	1	CC1300 Adaptor Plate
10	2900175	6	Cap Screw, Soc. Hd., 3/8-16 x 1"
11	2600062	1	Hydraulic Motor, Danfoss 1.16 cu. in.
12	2900006	2	Lock Washer, 3/8" Split
13	2900235	4	Cap Screw, Flat Hd., 3/8-16 x 1"
14	3200110	1	Elbow, 1/2" M. Pipe to 3/4" M. JIC
15	3200086	1	Elbow, 3/4" M. Pipe to 3/4" M. JIC
16	2500025	2	Sheave, 3.65-3 Groove
17	2500031	1	Taper Bushing, 1-1/8" w/Set Screws
18	2500337	1	Taper Bushing, 1-1/4"
19	2502192	2	Shim Plate
20	3200005	1	Ball Valve, 3/4" Pipe
21	3200083	2	Tee, 3/4" Pipe Run
22	3200097	2	Adapter, 3/4" M. JIC to 3/4" M. Pipe
23	3200100	1	Coupler, 3/4" Quick Disconnect
24	3200101	1	Nipple, 3/4" Quick Disconnect
25	2900389	2	U-Bolt, 3/4" Pipe x 1/4-20
26	2900009	4	Flat Washer, 1/4" SAE
27	2900024	4	Lock Washer, 1/4" Split
28	2900125	4	Hex Nut, 1/4-20
29	2900333	4	Cap Screw, Hex Hd., M10-1.5 x 25mm
30	2900321	4	Lock Washer, M10 Split
31	2901356	4	Flat Washer, M10
32	2500035	3	V-Belt, 3VX335
33	6048255	1	Weight, Saw
34	2900251	2	Cap Screw, Flat Hd., 3/8-18 x 1-3/4"
35	4645188	1	Hose Assembly, 3/4"
36	6040172	1	Hose Assembly, 3/4"

6048337 HYDRAULIC MOTOR OPTION, 1.55CI

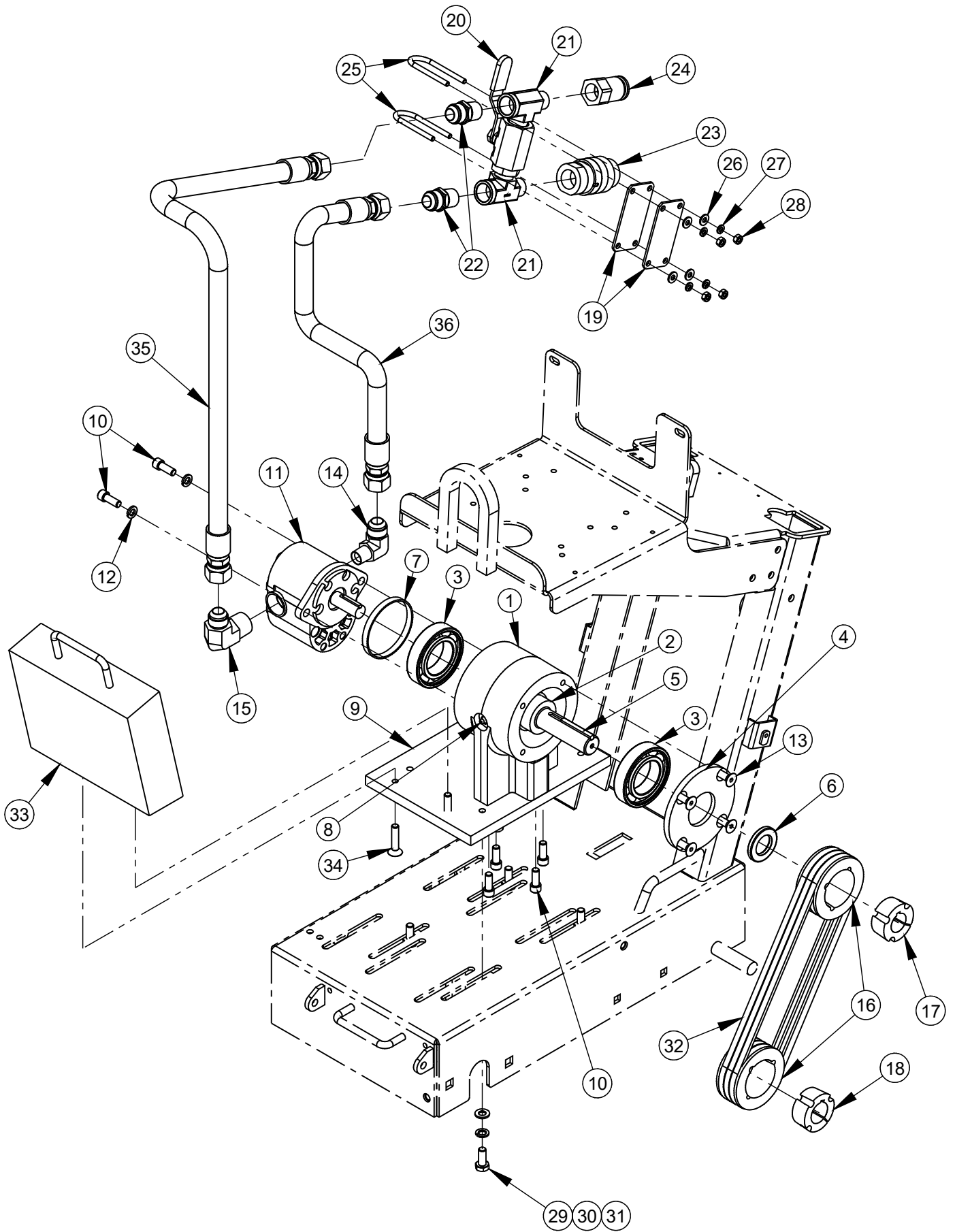

6048337 HYDRAULIC MOTOR OPTION, 1.55CI

ITEM	PART NO.	QTY.	DESCRIPTION
1	6048115	1	Pillow Block
2	6048116	1	Hydraulic Spindle Shaft
3	2500686	2	Bearing, 50mm x 90mm x 20mm
4	6048117	1	Seal Plate
5	6048134	1	Key, 1/4" Sq. x 2-1/4"
6	3200004	1	Seal, 1-1/8" x 2" x 1/4"
7	4699901	1	Shim For Hydraulic Spindle Shaft
8	2900062	1	Grease Fitting, 1/8" NPT
9	6048872	1	CC1300 Adaptor Plate
10	2900175	6	Cap Screw, Soc. Hd., 3/8-16 x 1"
11	2600063	1	Hydraulic Motor, Danfoss 1.55 cu. in.
12	2900006	2	Lock Washer, 3/8" Split
13	2900235	4	Cap Screw, Flat Hd., 3/8-16 x 1"
14	3200110	1	Elbow, 1/2" M. Pipe to 3/4" M. JIC
15	3200111	1	Elbow, 1" M. Pipe to 3/4" M. JIC
16	2500025	2	Sheave, 3.65-3 Groove
17	2500031	1	Taper Bushing, 1-1/8" w/Set Screws
18	2500337	1	Taper Bushing, 1-1/4"
19	2502192	2	Shim Plate
20	3200005	1	Ball Valve, 3/4" Pipe
21	3200083	2	Tee, 3/4" Pipe Run
22	3200097	2	Adapter, 3/4" M. JIC to 3/4" M. Pipe
23	3200100	1	Coupler, 3/4" Quick Disconnect
24	3200101	1	Nipple, 3/4" Quick Disconnect
25	2900389	2	U-Bolt, 3/4" Pipe x 1/4-20
26	2900009	4	Flat Washer, 1/4" SAE
27	2900024	4	Lock Washer, 1/4" Split
28	2900125	4	Hex Nut, 1/4-20
29	2900333	4	Cap Screw, Hex Hd., M10-1.5 x 25mm
30	2900321	4	Lock Washer, M10 Split
31	2901356	4	Flat Washer, M10
32	2500035	3	V-Belt, 3VX335
33	6048255	1	Weight, Saw
34	2900251	2	Cap Screw, Flat Hd., 3/8-18 x 1-3/4"
35	4645188	1	Hose Assembly, 3/4"
36	6040172	1	Hose Assembly, 3/4"

6048338 HYDRAULIC MOTOR OPTION, 1.94CI

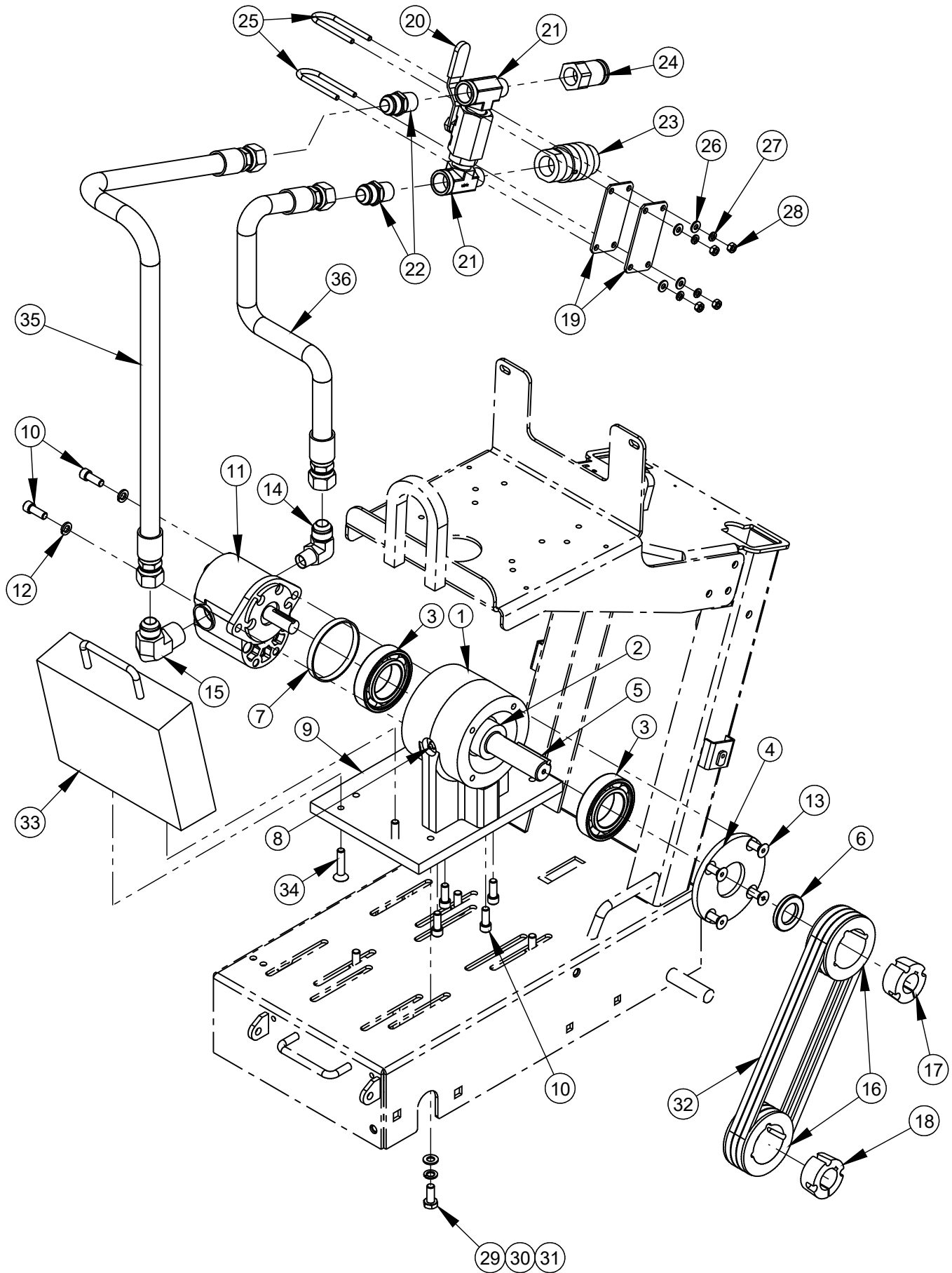

6048338 HYDRAULIC MOTOR OPTION, 1.94CI

ITEM	PART NO.	QTY.	DESCRIPTION
1	6048115	1	Pillow Block
2	6048116	1	Hydraulic Spindle Shaft
3	2500686	2	Bearing, 50mm x 90mm x 20mm
4	6048117	1	Seal Plate
5	6048134	1	Key, 1/4" Sq. x 2-1/4"
6	3200004	1	Seal, 1-1/8" x 2" x 1/4"
7	4699901	1	Shim For Hydraulic Spindle Shaft
8	2900062	1	Grease Fitting, 1/8" NPT
9	6048872	1	CC1300 Adaptor Plate
10	2900175	6	Cap Screw, Soc. Hd., 3/8-16 x 1"
11	2600064	1	Hydraulic Motor, Danfoss 1.94 cu. in.
12	2900006	2	Lock Washer, 3/8" Split
13	2900235	4	Cap Screw, Flat Hd., 3/8-16 x 1"
14	3200110	1	Elbow, 1/2" M. Pipe to 3/4" M. JIC
15	3200111	1	Elbow, 1" M. Pipe to 3/4" M. JIC
16	2500025	2	Sheave, 3.65-3 Groove
17	2500031	1	Taper Bushing, 1-1/8" w/Set Screws
18	2500337	1	Taper Bushing, 1-1/4"
19	2502192	2	Shim Plate
20	3200005	1	Ball Valve, 3/4" Pipe
21	3200083	2	Tee, 3/4" Pipe Run
22	3200097	2	Adapter, 3/4" M. JIC to 3/4" M. Pipe
23	3200100	1	Coupler, 3/4" Quick Disconnect
24	3200101	1	Nipple, 3/4" Quick Disconnect
25	2900389	2	U-Bolt, 3/4" Pipe x 1/4-20
26	2900009	4	Flat Washer, 1/4" SAE
27	2900024	4	Lock Washer, 1/4" Split
28	2900125	4	Hex Nut, 1/4-20
29	2900333	4	Cap Screw, Hex Hd., M10-1.5 x 25mm
30	2900321	4	Lock Washer, M10 Split
31	2901356	4	Flat Washer, M10
32	2500035	3	V-Belt, 3VX335
33	6048255	1	Weight, Saw
34	2900251	2	Cap Screw, Flat Hd., 3/8-18 x 1-3/4"
35	4645188	1	Hose Assembly, 3/4"
36	6040172	1	Hose Assembly, 3/4"

Blade Shaft Assembly, #6041041

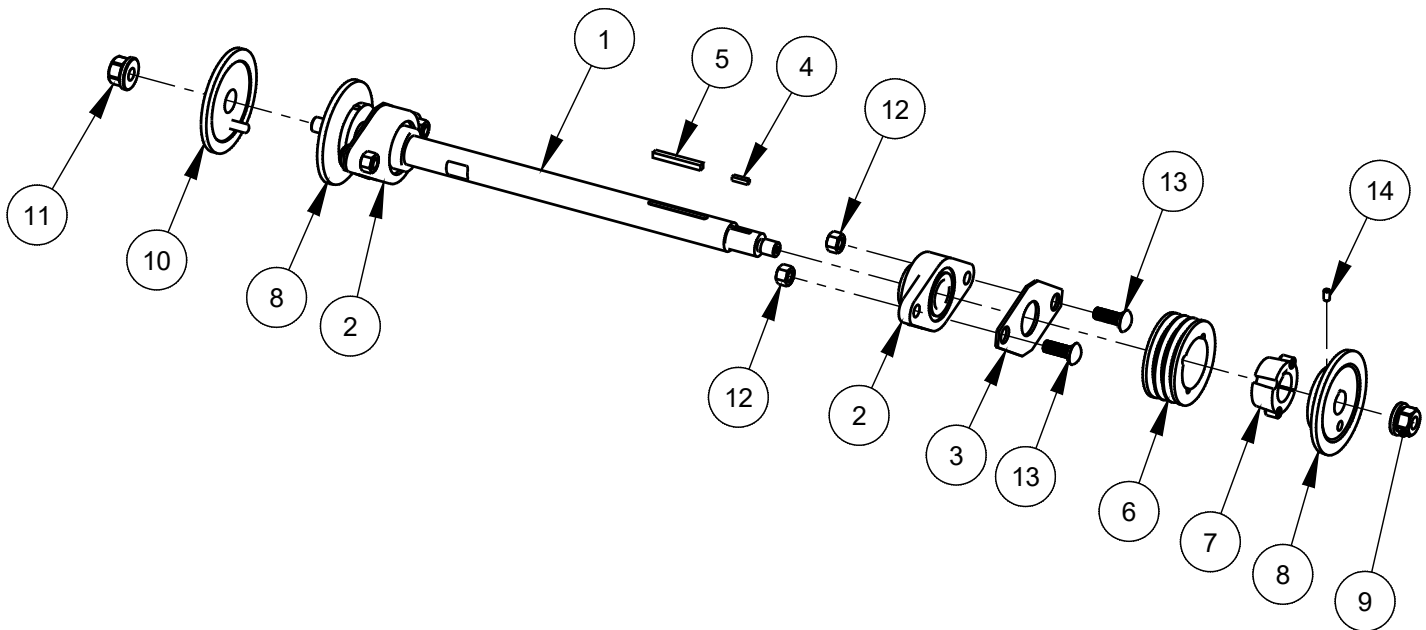
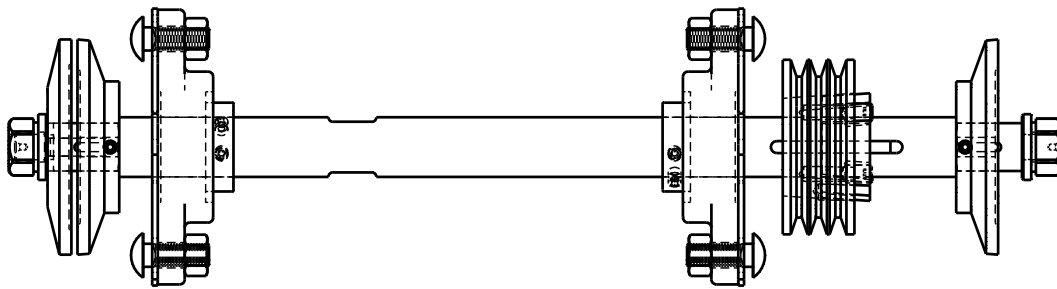

ITEM	PART NO.	QTY.	DESCRIPTION
1	6048866	1	Blade Shaft
2	2500576	2	Flange Block Bearing, 1-1/4"
3	6048037	2	Bearing Spacer
4	6048018	2	Key, 3/16" Sq. x 3/4"
5	6048134	1	Key, 1/4" Sq. x 2-1/4"
6	2500025	1	Sheave, 3.65-3 Groove
7	2500337	1	Taper Bushing, 1-1/4"
8	6048008	2	Inner Flange 4-1/2"
9	2900065	1	Flange Nut, 5/8-11 R.H.
10	6048009	1	Outer Flange, 4-1/2" w/ Pin
11	2900066	1	Flange Nut, 5/8-11, L. Hand
12	2900327	4	Lock Nut, M12-1.75 Nylon Insert
13	2900322	4	Carriage Bolt, M12-1.75 x 35
14	2900076	2	Set Screw, Soc. Hd., 1/4-20 x 1/2"

6040500 BLADE SHAFT ASSEMBLY, 10 HP, 230/460 VOLT

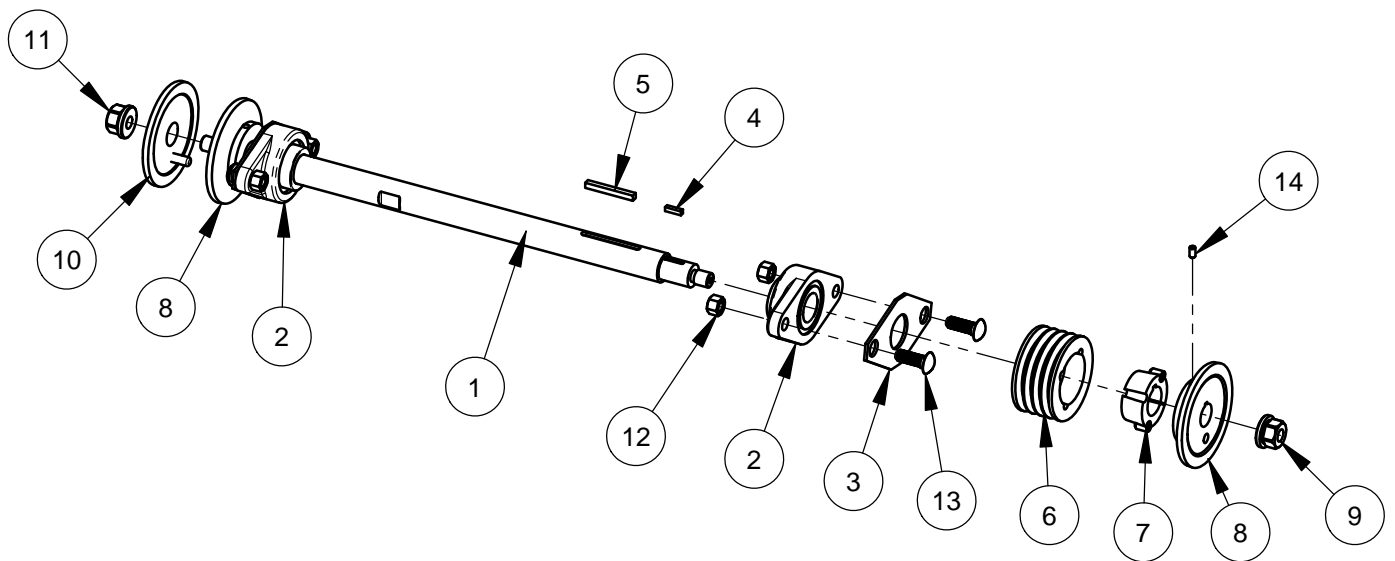
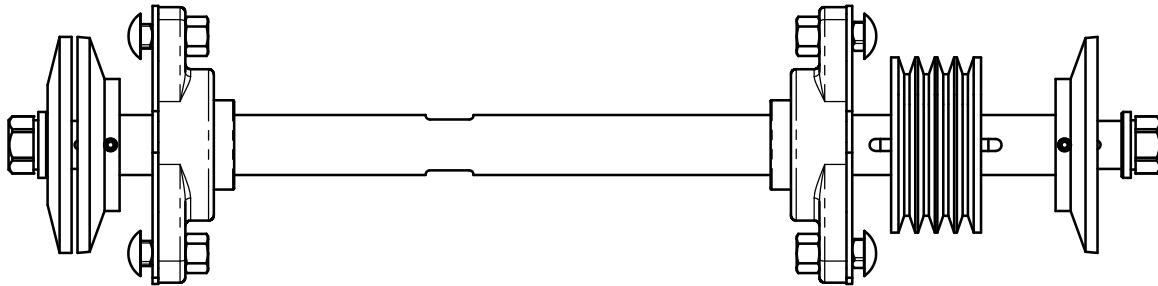

**ALSO FIT 575 VOLT MODELS
PRIOR TO MARCH 2011.**

ITEM	PART NO.	QTY.	DESCRIPTION
1	6048865	1	Blade Shaft
2	2500576	2	Flange Block Bearing, 1-1/4"
3	6048037	2	Bearing Spacer
4	6048018	2	Key, 3/16" Sq. x 3/4"
5	6048134	1	Key, 1/4" Sq. x 2-1/4"
6	2500621	1	Sheave, 3V-3.65-4 Groove (1610)
7	2500337	1	Taper Bushing, 1-1/4" w/ Set Screws
8	6048008	2	Inner Flange 4-1/2"
9	2900065	1	Flange Nut, 5/8-11 R.H.
10	6048009	1	Outer Flange, 4-1/2" w/ Pin
11	2900066	1	Flange Nut, 5/8-11 L.H.
12	2900327	4	Lock Nut, M12 Nylon
13	2900322	4	Carriage Bolt, M12-1.75 x 35
14	2900076	2	Set Screw, Soc. Hd., 1/4-20 x 1/2"

6040528 BLADE SHAFT ASSEMBLY, 575V UNITS.

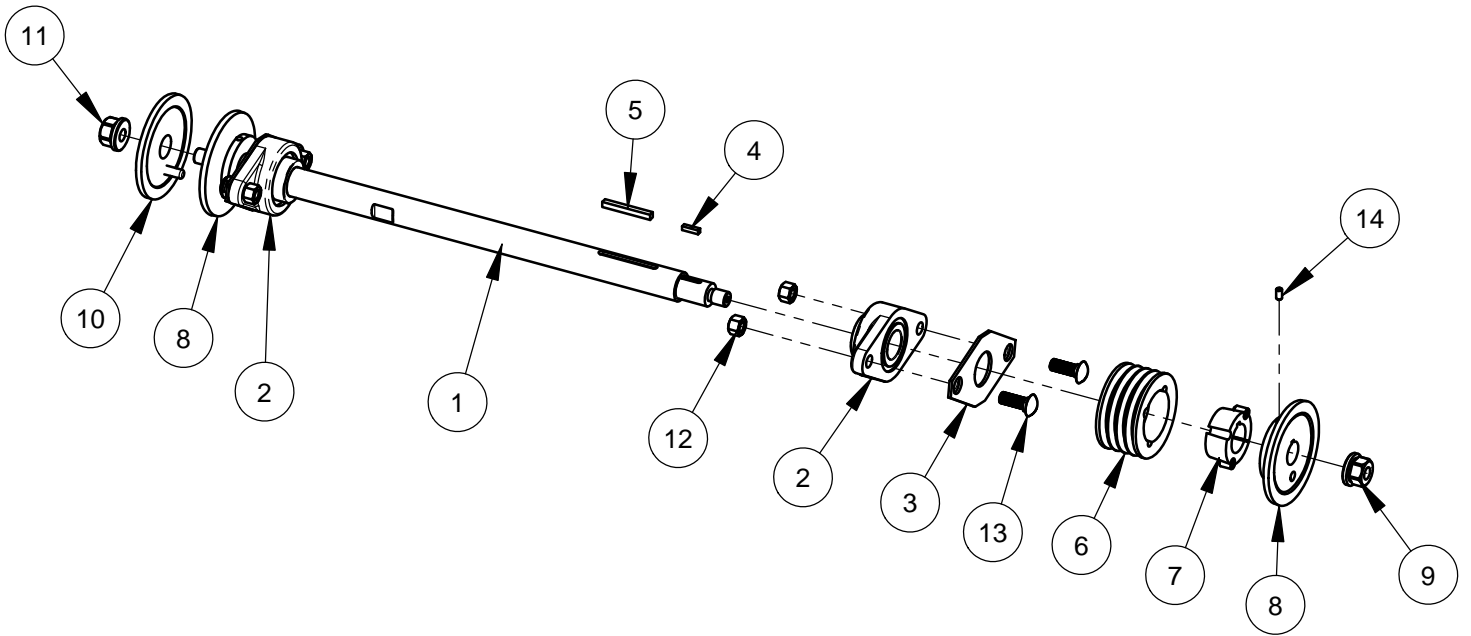
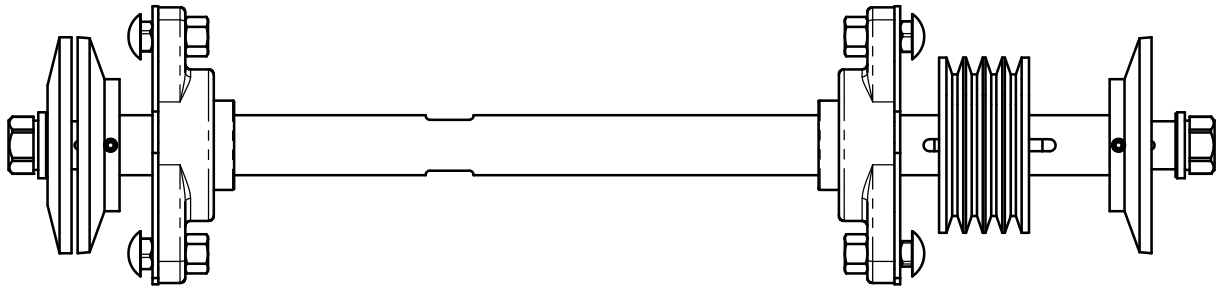

ITEM	PART NO.	QTY.	DESCRIPTION
1	6048880	1	Blade Shaft
2	2500576	2	Flange Block Bearing, 1-1/4"
3	6048037	2	Bearing Spacer
4	6048018	2	Key, 3/16" Sq. x 3/4"
5	6048134	1	Key, 1/4" Sq. x 2-1/4"
6	2500621	1	Sheave, 3V-3.65-4 Groove (1610)
7	2500337	1	Taper Bushing, 1-1/4" w/ Set Screws
8	6048008	2	Inner Flange 4-1/2"
9	2900065	1	Flange Nut, 5/8-11 R.H.
10	6048009	1	Outer Flange, 4-1/2" w/ Pin
11	2900066	1	Flange Nut, 5/8-11 L.H.
12	2900327	4	Lock Nut, M12 Nylon
13	2900322	4	Carriage Bolt, M12-1.75 x 35
14	2900076	2	Set Screw, Soc. Hd., 1/4-20 x 1/2"

14" Blade Guard Assembly
#6048912

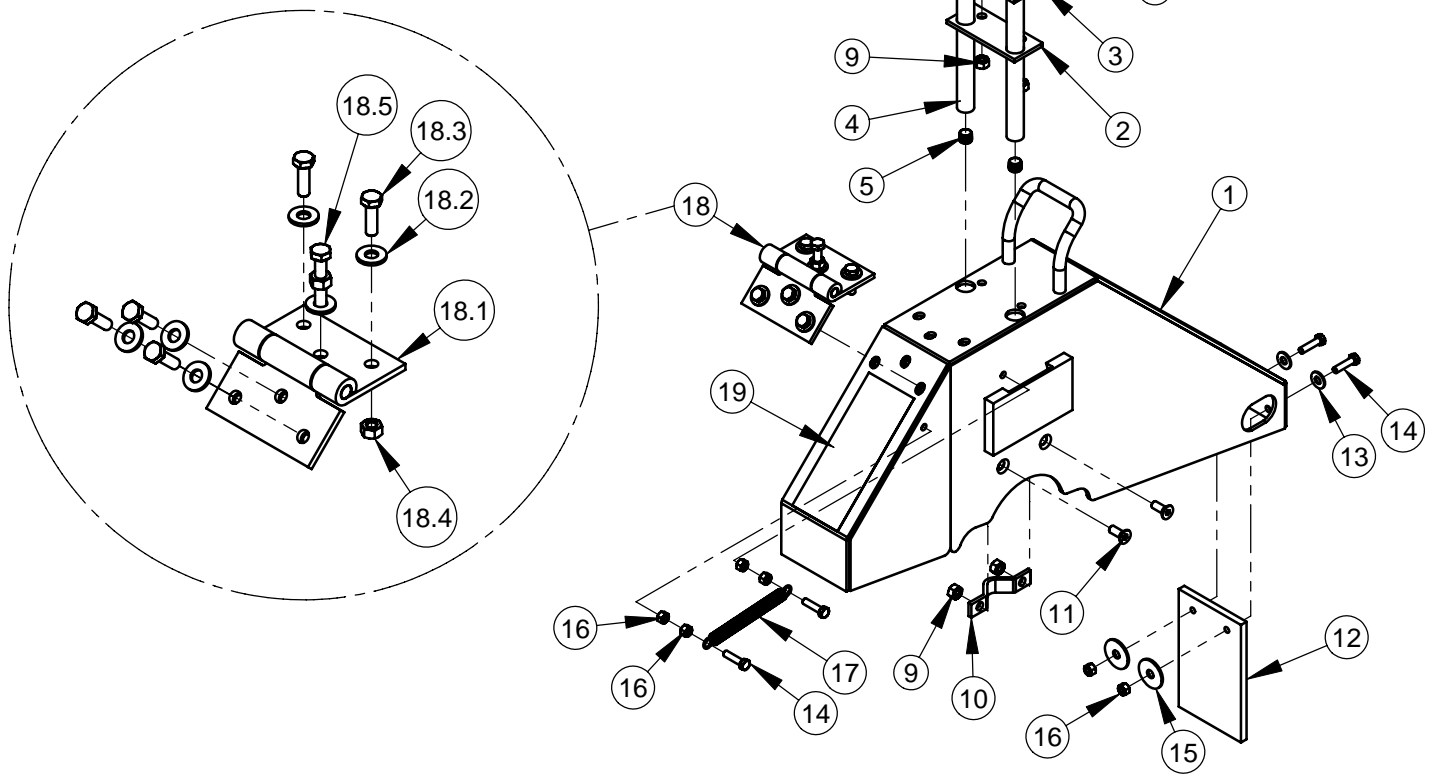

ITEM	PART NO.	QTY.	DESCRIPTION
1	6048911	1	14" Blade Guard
2	2500829	1	Water Manifold Gasket
3	6048123	1	Water Manifold
4	6048283	2	Water Tube for 14" Guard
5	3200001	3	Plug, 1/8" NPT
6	3200002	1	Fitting, 3/8" M. Pipe to 3/4" M. Garden
7	2900009	2	Flat Washer, 1/4" SAE
8	2900244	2	Cap Screw, Hex Hd., M6 x 45mm
9	2900302	6	Lock Nut, M6 Nylon
10	6048155	2	Water Tube Clamp
11	2900308	4	Cap Screw, Flat Hd. Soc., M6 x 16mm
12	6048039	1	Splash Flap
13	2900016	2	Flat Washer, #10 USS
14	2900309	4	Cap Screw, Hex Hd., M5 x 20mm
15	2900083	2	Fender Washer, 1/4" I.D. x 1-1/4" O.D.
16	2900301	6	Lock Nut, M5 Nylon
17	2500066	1	Spring, 3/8 X .055 X 3"
18	6048026	1	Hinge Assy., Metric Fasteners
18.1	2500270	1	Blade Guard Hinge
18.2	2900009	6	Flat Washer, 1/4" SAE
18.3	2900310	5	Cap Screw, Hex Hd., M6 x 20mm
18.4	2900302	7	Lock Nut, M6 Nylon
18.5	2900312	1	Cap Screw, Hex Hd., M6 x 35mm
19	1800001	1	Warning Label

18" Blade Guard Assembly
6048910

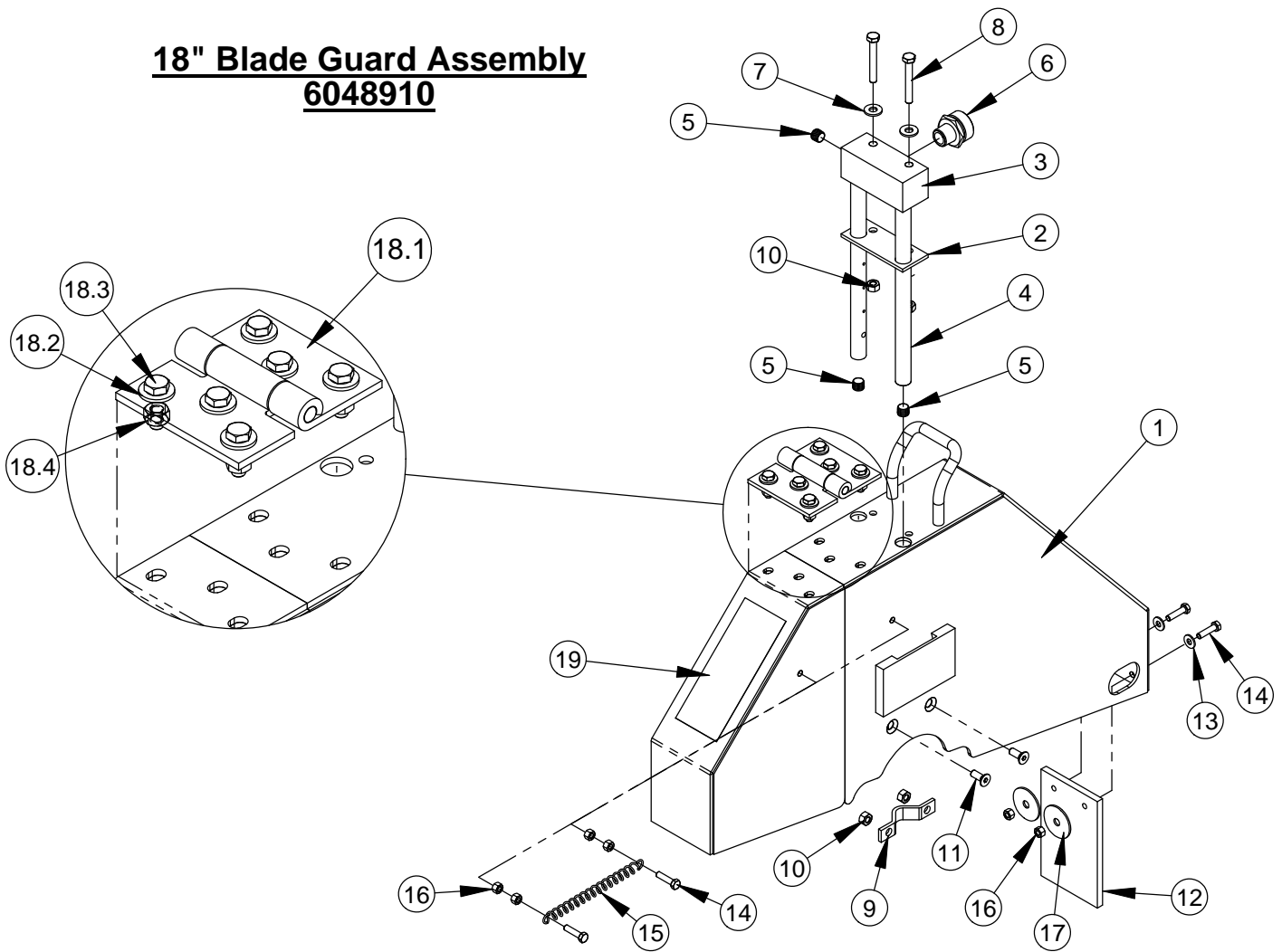

ITEM	PART NO.	QTY.	DESCRIPTION
1	6048909	1	18" Blade Guard Assembly
2	2500829	1	Water Manifold Gasket
3	6048123	1	Water Manifold
4	6048243	2	Water Tube for 18" Guard
5	3200001	3	Plug, 1/8" NPT
6	3200002	1	Fitting, 3/8" M. Pipe to 3/4" M. Garden
7	2900009	2	Flat Washer, 1/4" SAE
8	2900244	2	Cap Screw, Hex Hd., M6-1.0 x 45mm
9	6048155	2	Water Tube Clamp
10	2900302	6	Lock Nut, M6 Nylon
11	2900308	4	Cap Screw, Flat Hd., M6-1.0 x 16mm
12	6048039	1	Splash Flap
13	2900016	2	Flat Washer, #10 USS
14	2900309	4	Cap Screw, Hex Hd., M5-0.8 x 20mm
15	2500067	1	Spring, 3/8" x 4"
16	2900301	6	Lock Nut, M5-0.8 Nylon Insert
17	2900083	2	Fender Washer, 1/4" x 1-1/4"
18	6048027	1	Hinge Assy., Metric Fasteners
18.1	2500270	1	Blade Guard Hinge
18.2	2900009	6	Flat Washer, 1/4" SAE
18.3	2900310	6	Cap Screw, Hex Hd., M6 x 20mm
18.4	2900302	6	Lock Nut, M6 Nylon
19	1800001	1	Warning Label

20" Blade Guard Assembly #6048904

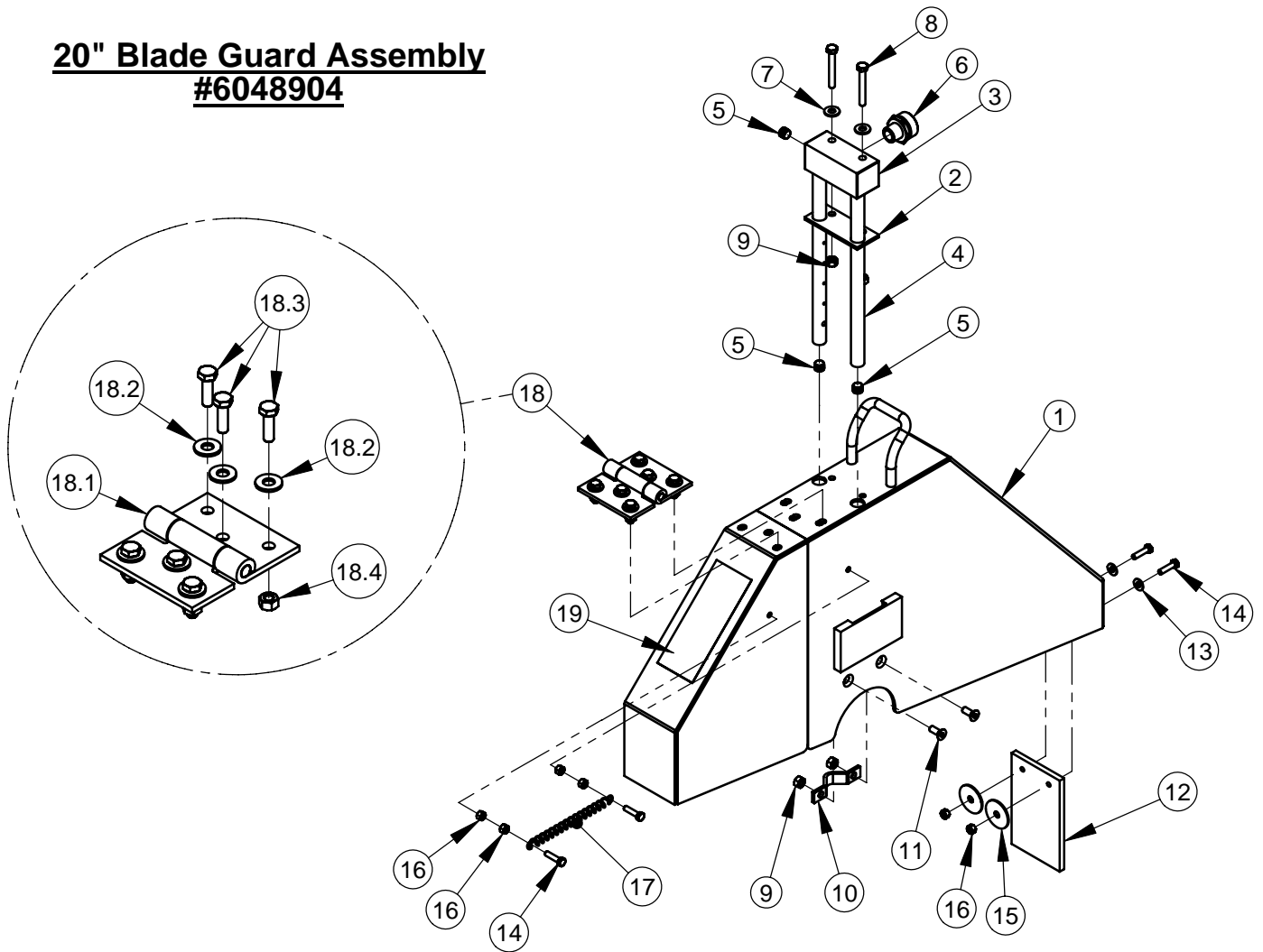

ITEM	PART NO.	QTY.	DESCRIPTION
1	6048905	1	20" Blade Guard
2	2500829	1	Water Manifold Gasket
3	6048123	1	Water Manifold
4	6010085	2	Water Tube for 20" Guard
5	3200001	3	Plug, 1/8" NPT
6	3200002	1	Fitting, 3/8" M. Pipe to 3/4" M. Garden
7	2900009	2	Flat Washer, 1/4" SAE
8	2900244	2	Cap Screw, Hex Hd., M6 x 45mm
9	2900302	6	Lock Nut, M6 Nylon
10	6048155	2	Water Tube Clamp
11	2900308	4	Cap Screw, Flat Hd. Soc., M6 x 16mm
12	6048039	1	Splash Flap
13	2900016	2	Flat Washer, #10 USS
14	2900309	4	Cap Screw, Hex Hd., M5 x 20mm
15	2900083	2	Fender Washer, 1/4" x 1-1/4"
16	2900301	6	Lock Nut, M5 Nylon
17	2500067	1	Spring, 3/8" x 4"
18	6048027	1	Hinge Assy., Metric Fasteners
18.1	2500270	1	Blade Guard Hinge
18.2	2900009	6	Flat Washer, 1/4" SAE
18.3	2900310	6	Cap Screw, Hex Hd., M6 x 20mm
18.4	2900302	6	Lock Nut, M6 Nylon
19	1800001	1	Warning Label

6048080 POINTER ASSEMBLY

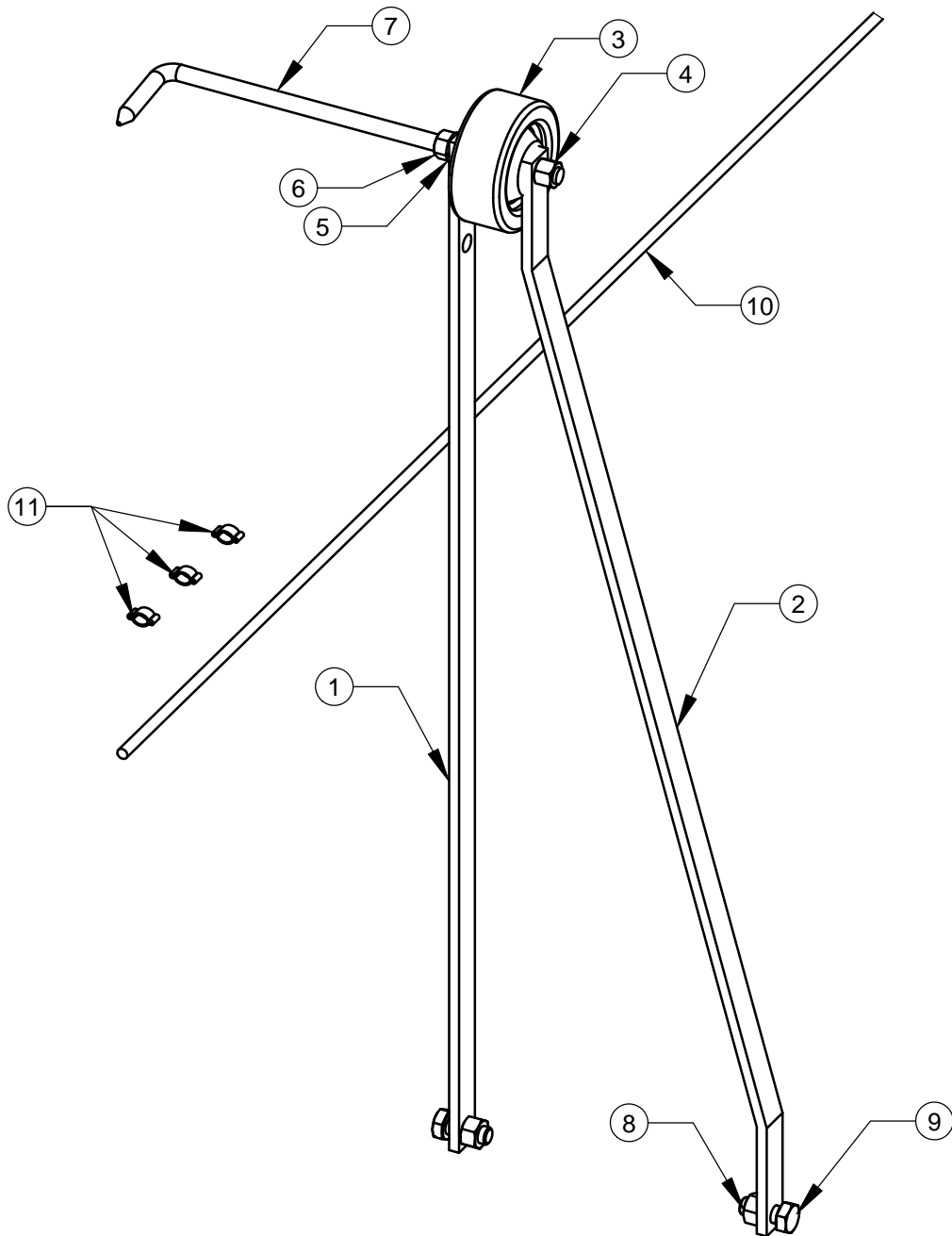

ITEM NO.	PART NUMBER	QTY.	DESCRIPTION
1	6048069	1	Pointer Bar - Straight
2	6048070	1	Pointer Bar - Offset
3	2500624	1	Wheel, 3"
4	2900018	1	Lock Nut, 3/8-16 Nylon
5	2900006	1	Lock Washer, 3/8" Split
6	2900033	1	Hex Nut, 3/8-16
7	2900032	1	Pointer Rod
8	2900304	2	Lock Nut, M10-1.5 Nylon Insert
9	2900333	2	Cap Screw, Hex Hd., M10-1.5 x 25mm
10	6048078	1	Rope, 1/4 x 78"
11	3200221	3	Pinch Clamp, Two Ear

6047994 POINTER ASSEMBLY, 10 HP UNITS

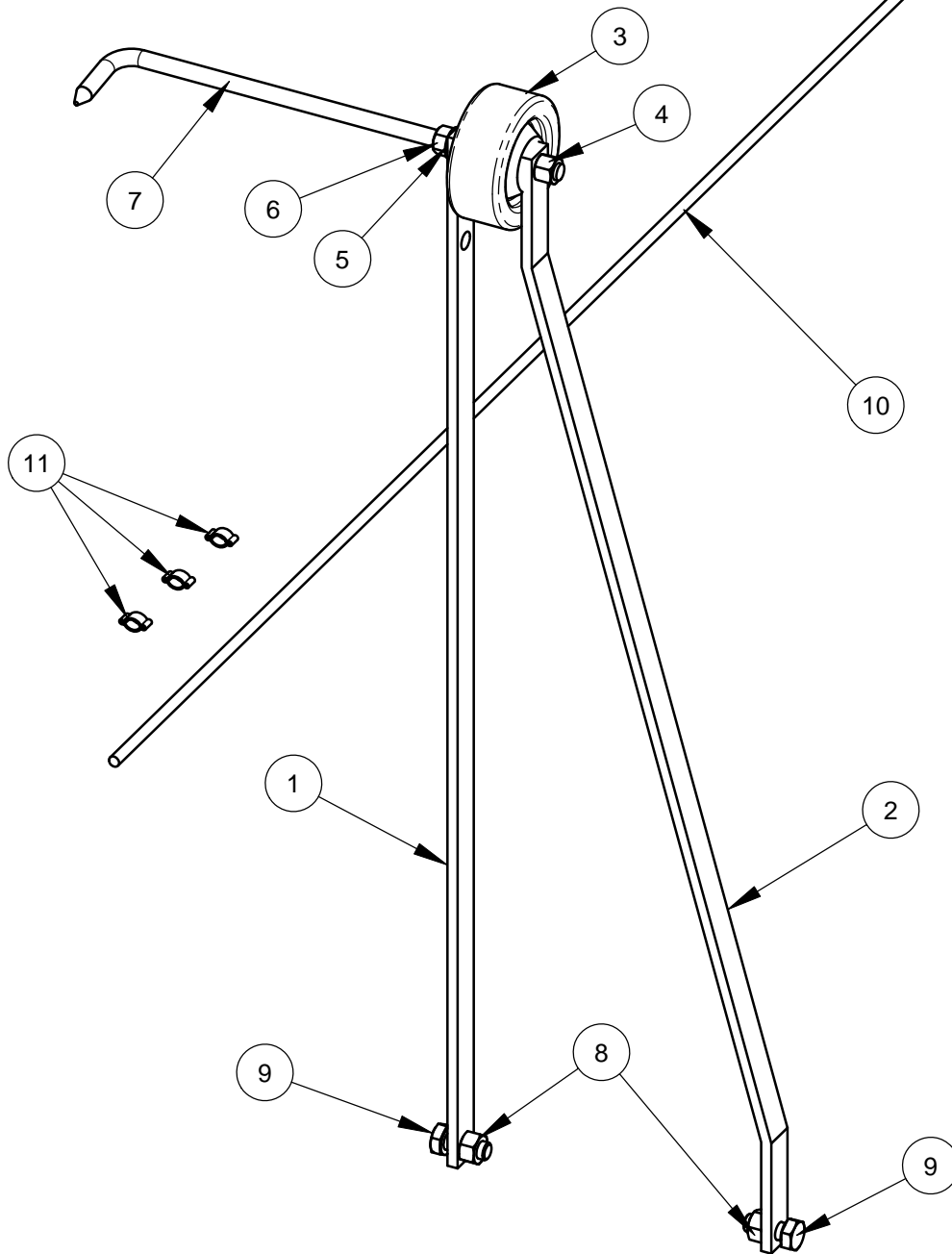

ITEM	PART NO.	QTY.	DESCRIPTION
1	6048069	1	Pointer Bar - Straight
2	6048070	1	Pointer Bar - Offset
3	2500624	1	Wheel, 3"
4	2900018	1	Lock Nut, 3/8-16 Nylon
5	2900321	1	Lock Washer, M10 Split
6	2900033	1	Hex Nut, 3/8-16
7	2900743	1	Pointer Rod, 11"
8	2900304	2	Lock Nut, M10-1.5 Nylon Insert
9	2900333	2	Cap Screw, Hex Hd., M10-1.5 x 25mm
10	6048078	1	Rope, 1/4 x 78"
11	3200221	3	Pinch Clamp, Two Ear

EQUIPMENT AND PARTS WARRANTY

Diamond Products warrants all equipment manufactured by it against defects in workmanship or materials for a period of one (1) year from the date of shipment to Customer.

The responsibility of Diamond Products under this Warranty is limited to replacement or repair of defective parts at Diamond Products' Elyria, Ohio factory, or at a point designated by it, of such parts as shall appear to us upon inspection at such parts, to have been defective in material or workmanship, with expense for transportation and labor borne by Customer.

In no event shall Diamond Products be liable for consequential or incidental damages arising out of the failure of any Product to operate properly.

Integral units such as engines, electric motors, batteries, transmissions, etc., are excluded from this Warranty and are subject to the prime manufacturer's warranty.

THIS WARRANTY IS IN LIEU OF ALL OTHER WARRANTIES, EXPRESSED OR IMPLIED, AND ALL SUCH OTHER WARRANTIES ARE HEREBY DISCLAIMED.



333 Prospect Street, Elyria, Ohio 44035
(440) 323-4616 • (800) 321-5336 • Fax (440) 323-8689
www.diamondproducts.com