



**CORE CUT
OPERATOR'S MANUAL**

**CC7574DD-PRO
CC7574DD-PRO-3
CC7574DDC-PRO**

AUGUST 2024

Part #: 1803091-00

Table of Contents

Introduction..... 7

 CC7574DD-PRO Controls..... 8

 CC7574DD-PRO Dimensions 10

 CC7574DD-PRO Specifications 11

 CC7574DD-PRO-3 Specifications..... 12

Safety Precautions 13

 Safety..... 13

 Safety Alerts..... 13

 Proposition 65 13

 Spark Arrester Requirement..... 13

 Respiratory Hazards..... 13

 Battery and Electrical Safety..... 15

 Blade Safety..... 15

 Blade Guard Safety 15

 Fuel Safety..... 16

 Engine Safety..... 16

 Cutting Safety..... 16

 Hydraulic Safety 17

 Belt Safety..... 17

 Transporting Safety 17

 Lifting Safety..... 17

Display Panel Controller 18

 Controller Features 18

 Flat Screen Display 18

 Function Keys..... 21

 Soft Key Commands 21

 Main Menu Key 22

 Engine Diagnostics..... 23

 User Settings..... 24

 Utilities..... 25

Operation 26

 Blade Size Selection..... 26

 Blade Speed..... 27

 Zero the Blade..... 27

 Set the Blade Depth Stop 28

 Deactivate the Blade Depth Stop Setting..... 28

Operating..... 29

 Tie-Downs..... 29

 Footrest..... 29

 Weight Bar (Optional)..... 29

 Spotlight..... 29

 Handlebars 29

 Adjusting the Handlebars 29

 Control Grip Pushbuttons 30

Fuel System	30
Adding Fuel	30
Blade Guard	30
Installing the Blade Guard	31
Removing the Blade Guard	31
Flange Guard	31
Installing the Flange Guard.....	31
Removing the Flange Guard.....	31
Diamond Blades.....	31
Inspecting the Blade	32
Blade Speed.....	32
Wrench.....	32
Installing the Blade	32
Removing the Blade	33
Engine.....	34
Tasks Prior to Starting the Engine	34
Starting the Engine	34
Stopping the Engine	34
Speed Control Lever	35
Blade Lowering Speed	35
Water Supply	35
Using the Water Supply	35
Water Pump (Optional).....	36
Automatic Water System (AWS).....	36
Cutting Guides	36
Adjusting the Front Pointer	36
Adjusting the Rear Pointer(s).....	36
Concrete Cutting	37
Helpful Hints Prior to Cutting	37
Tasks Prior to Cutting	37
Making a Cut	37
Making a Cut Using the Blade Depth Stop.....	37
Continuing a Partial Cut.....	38
Finishing a Cut	38
Hood Operation.....	38
Shifting the Three Speed Transmission.....	38
Maintenance	39
General.....	39
Maintenance Tools.....	39
Pre-Maintenance Preparations.....	39
General Cleaning	39
Cleaning Techniques.....	39
Radiator.....	39
Control Panel.....	39
Engine	40
Part Lubrication	40

CC7574DD-PRO OPERATOR'S MANUAL

Post Cleaning	40
Service Schedule	41
Daily Service	42
Check Engine Oil Level	42
Check Fuel Level	42
Hydraulic System	42
Check Hydraulic Fluid Level for Hydro Pump Assembly	43
Adding Fluid to the Hydraulic Lift Pump	43
Checking Radiator Coolant Level	43
Check and Clean Blade Guard Spray Tubes.....	44
Check the Air Cleaner Restriction Indicator	44
Rubber Dust Ejector Boot.....	44
Draining the Upper Gearbox Heat Sink (Cold Weather Only)	44
50 Hour Service	44
Drain the Fuel/Water Separator Filter.....	44
Lubricate the Hydraulic Cylinder Pivot Pin.....	45
Lubricate Front Axle Pivot Bearings	45
Lubricate the Optional Bogie Wheel	45
100 Hour Service	46
Upper Gearbox	46
Changing the Upper Gearbox Oil.....	46
(Single Speed).....	46
Changing the Upper Gearbox Oil.....	46
(3-Speed)	46
Lower Gearbox	46
Changing the Lower Gearbox Oil.....	46
Cleaning the In-Line Oil Suction Filter	47
250 Hour Service	47
Check and Clean the Water System Inlet Strainer(s)	47
Clean the Air Cleaner Element.....	47
Changing the Engine Oil.....	48
500 Hour Service	49
Replacing the Hydraulic Oil Filter	49
Replace the Fuel/Water Separator Filter	50
Replace the Fuel Filter	50
Replacing the Outer Primary and Inner Safety Filters.....	51
1000 Hour Service.....	52
Changing the Radiator Fluid and Hoses.....	52
Lubricate the Blade Shaft Seals	52
1500 Service Hours	52
Replace the Oil Separator Element	52

CC7574DD-PRO OPERATOR'S MANUAL

Regular Maintenance.....	53
Speed Control Lever	53
Adjusting the Lever Tension	53
Adjusting the Spring Plungers	53
Inner Blade Flange.....	53
Installing the Inner Blade Flange	54
Removing the Inner Blade Flange.....	54
Drive Alignment.....	54
Adjusting the Drive Alignment.....	54
Wheels.....	54
Replacing the Front Wheels	54
Replacing the Rear Wheels	55
Maximum Cutting Depth.....	55
Handlebar Cylinder Rod.....	55
Removing the Cylinder Rod.....	56
Connecting the Cylinder Rod.....	56
Battery	56
Battery Type.....	56
Servicing the Battery	57
Electrical System	57
Belt Sheaves.....	57
Removing the Belt Sheaves	57
Installing Belt Sheaves	58
Blade Drive Belts	58
Tensioning/Replacing the Blade Drive Belts	58
Engine.....	59
Cleaning the Engine	59
Storing	59
Disposal.....	59
References.....	60
Appendix A	60
Troubleshooting.....	60
Appendix B	62
CC7574DD-PRO RPM Chart	62
CC7574DD-PRO-3 RPM Charts.....	62
CC7574DD-PRO Blade Size Conversion Chart.....	64
CC7574DD-PRO-3 Blade Size Conversion Chart.....	65
Appendix C	66
Additional Resources.....	66
Appendix D	67
Model and Serial Numbers	67

Introduction

Welcome to the Diamond Products family and thank you for choosing Diamond Products equipment. At Diamond Products we are driven to ensure you are completely satisfied with your product and continually strive to improve our product line so that we can offer you the best possible equipment in the industry.

This operator's manual is a critical document that provides pertinent information regarding the safety, operation, maintenance, and care of your new equipment. Keep this manual available at all times. Operate the equipment and all of its components according to this manual. Failure to comply with and understand the following safety, operation and maintenance instructions can result in serious injuries and/or death. All operators must be properly trained or supervised by experienced personnel prior to using this equipment and should understand the risks and hazards involved. Diamond Products discourages improper or unintended equipment usage and cannot be held liable for any resulting damages.

Equipment modifications should be made by Diamond Products to ensure safety and design. Any modifications made by the owner(s) are not the responsibility of Diamond Products and void all equipment warranties if a problem arises as a result of the modification.

Refer to the Diamond Products Parts List for additional information and part diagrams. Refer to the engine/motor manual and manufacturer as the primary source for all safety, operations, and maintenance instructions regarding the engine/motor. Prior to operating, record the equipment's serial number, and the engine's/motor's model and serial numbers in Appendix D.

CC7574DD-PRO Controls

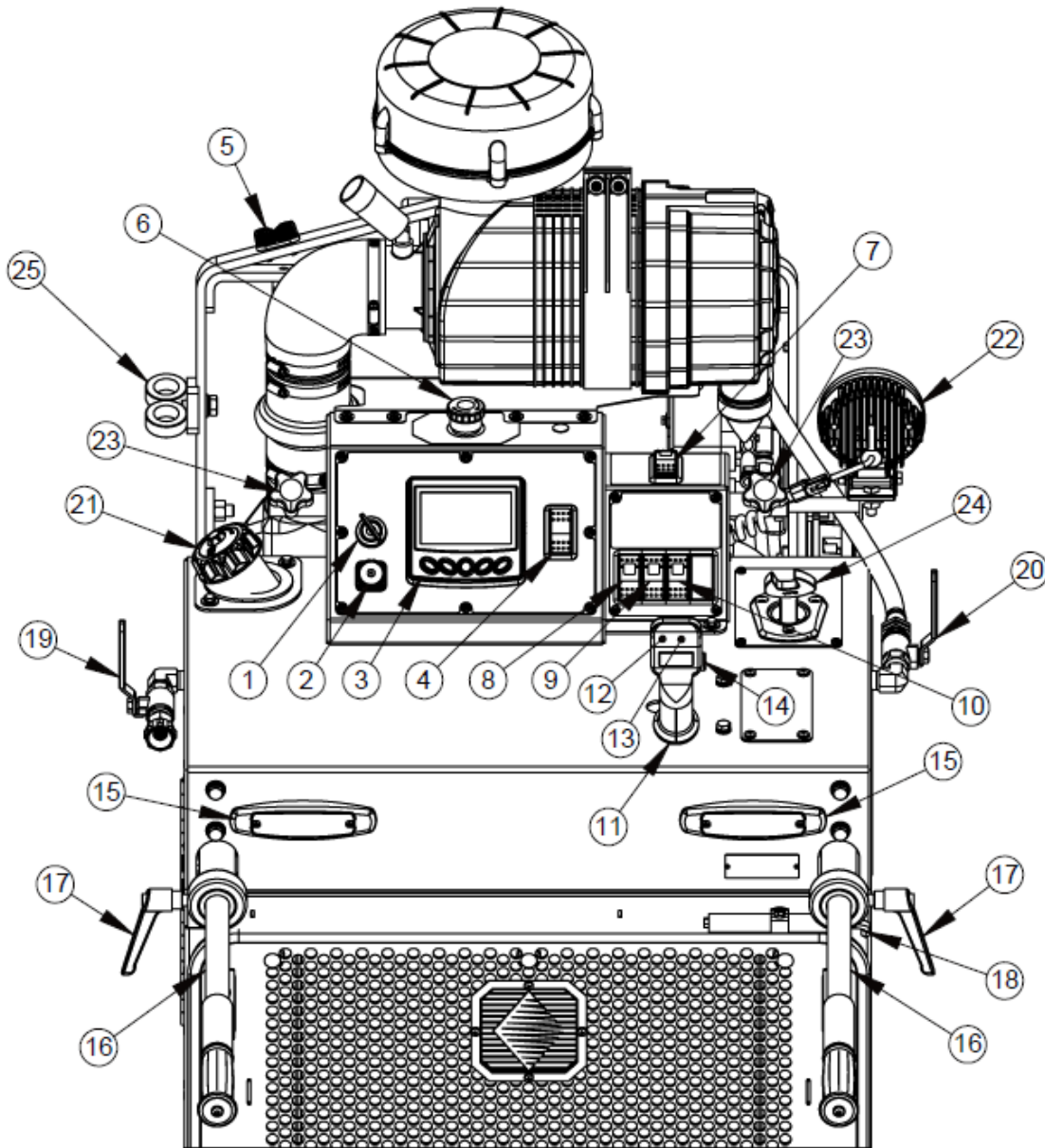

1. **Ignition Switch** – Starts the engine and provides power to certain components.
2. **Diagnosis Port** – Used by service personnel to monitor engine parameters.
3. **Engine Display Panel** – Monitors and displays various engine and machine parameters.
4. **Engine Throttle Switch** – Increases and decreases engine/blade speed (RPM).
5. **Pointer Rope Cleat** – Secures front pointer rope.
6. **Emergency Stop Button** – Stops the engine.

7. **Free Wheel Rocker Switch** – Allows operator to move saw forward/backward (with ignition switch at ON).
8. **LED Spotlight Switch** – Activates spotlight.
9. **Water Pump Switch (Optional)** – Activates water pump.
10. **Blade Clutch Switch (Optional)** – Allows for engaging/disengaging blade rotation.
11. **Travel Speed Control Lever** – Forward, reverse, and neutral control.
12. **Saw Raise Pushbutton** – Activates hydraulic pump to raise saw.
13. **Saw Lower Pushbutton** – Bleeds hydraulic pressure from lift cylinder to lower saw.

14. **Tilt Handlebar Pushbutton** – Adjusts angle of handlebars.
15. **LED Marker Light** – Illuminates when machine is on.
16. **Adjustable Handle Bar** – Allows for operator control of saw.
17. **Handlebar Lock Lever** – Locks the handlebar in position.
18. **Speed Control Friction Wrench** – Used to adjust pressure on the speed control friction washer.
19. **Water Metering Control Valve** – Controls water flow rate. Connects to the water source hose.
20. **Water On/Off Control Valve**- Turns water flow, to the saw blade, on and off.
21. **Fuel Filler Cap** – Fill Port.
22. **LED Spot Light** – Illuminates the work area.
23. **Spot Light Adjustment Knob** – Locks the spot light bar in place.
24. **Blade Shaft Wrench** – Used to install and remove blades from the blade shaft.
25. **Handlebar Storage** – Stores handlebars when not in use.

CC7574DD-PRO Dimensions

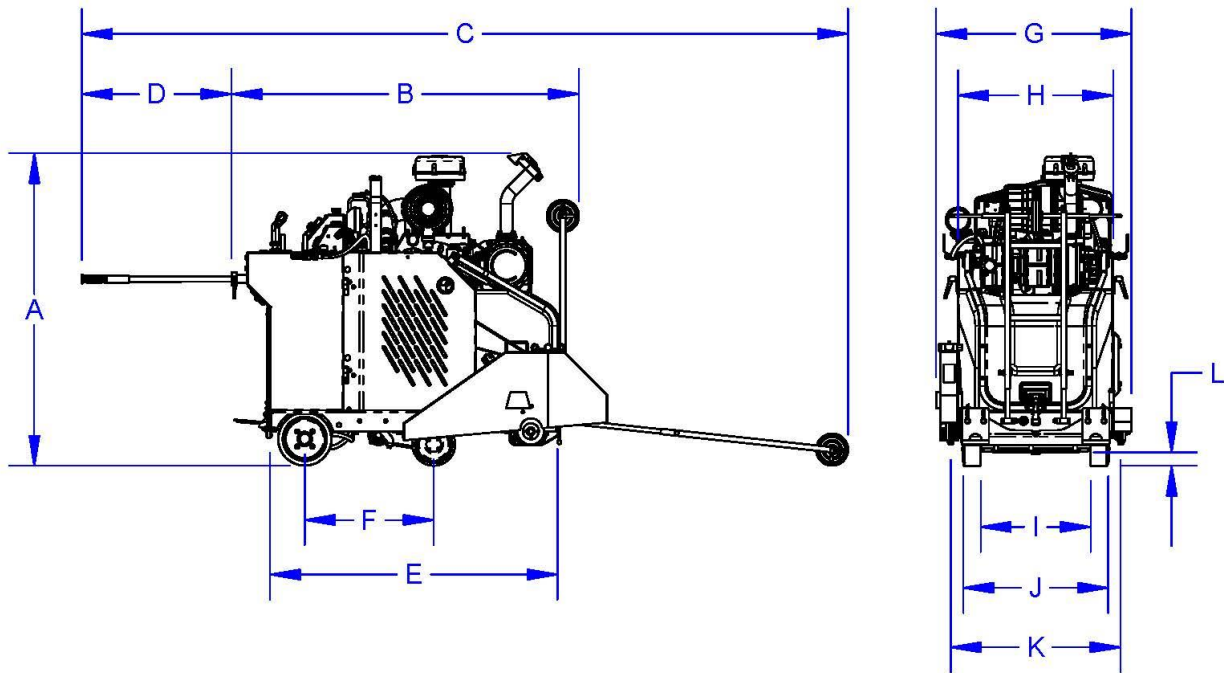

CC7475DD Dimensions		Inches	Millimeters
A	Saw Height	58-1/2	1486
B	Saw Length – Minimum	65	1651
C	Saw Length – Maximum	143	3632
D	Handle Extension – Maximum	28	711
E	Frame Length	53-3/4	1365
F	Wheel Base Length	24-1/4	616
G	Saw Width	36-1/2	927
H	Frame Width	29	737
I	Front Wheels Inside Width	20-1/2	520
J	Rear Wheels Outside Width	27-1/4	692
K	Inner Flange to Inner Flange Width	31-3/4	806
L₁	Ground Clearance (Saw Level)	2-1/2	63
L₂	Ground Clearance (Saw Raised)	1-3/4	44
-	Blade Raised Height - Maximum	26	660

CC7574DD-PRO OPERATOR'S MANUAL

CC7574DD-PRO Specifications

Saw Model	CC7574DD-PRO-20	CC7574DD-PRO-26	CC7574DD-PRO-30	CC7574DD-PRO-36	CC7574DD-PRO-42	CC7574DD-PRO-48
Blade Guard Capacity	20"	30"	30"	36"	42"	48"
Blade Cutting Depth Max	7.25"	10.25"	12.25"	14.75"	17.25"	19.75"
Blade Shaft Speed	2300 rpm	1875 rpm	1675 rpm	1375 rpm	1125 rpm	1000 rpm
Blade Flange Size	5" OD	5" OD	5" OD	6" OD	7" OD	8" OD
Operating Weight*	2110 lbs.	2128 lbs.	2129 lbs.	2145 lbs.	2165 lbs.	2174 lbs.
Crated Weight	2210 lbs.	2228 lbs.	2229 lbs.	2245 lbs.	2265 lbs.	2274 lbs.
Blade Guard Weight Only	25 lbs.	41 lbs.	49 lbs.	63 lbs.	72 lbs.	94 lbs.
Engine Brand Model	Deutz TD 2.9 L4, EMR5					
Emission Regulation	EPA-CARB Tier 4 Final					
Engine Type	2.9 liter, 4 cylinder, liquid cooled, turbo diesel					
Engine Max Power	74.3hp @ 2600 rpm (Deutz rating)					
Engine Peak Torque	192 Ft-Lbs (260 Nm) @ 1600 rpm					
Aftertreatment Device	Diesel Oxidation Catalyst (DOC)					
Engine Air Filtration	Dry dual element with spinner pre-cleaner and restriction indicator					
Battery	12 Volt (800 CCA) group size 24					
Starter / Alternator	Electric 3.5hp (2.6kW) / 55 Amp, 14V					
Fuel Type	Ultra low sulfur diesel (Cetane 45 min)					
Fuel Tank	8.5 Gallon (32 Liter) with electronic low fuel level indication					
Engine Oil	SAE 15W-40 API class CJ-4 (8.5 Quarts/8.0 Liter)					
Radiator Coolant	50/50 Pre-mixed (3 Gallon/11.3 Liter)					
Wheel Motor Pump Fluid	SAE 15W-40 (2 Liter capacity)					
Saw Lift Pump Fluid	SAE 15W-40 (2 Liter capacity)					
Lubrication Type	NLGI #2 Lithium grease					
Blade Arbor Size	1" Diameter with drive pin					
Blade Flange Type	Quick disconnect					
Blade Shaft Size	45mm OD with left/right side blade mounting					
Blade Shaft Bearings	6 High precision ball bearings					
Blade Shaft Drive	20 V-Belts (3VX)					
Blade Coolant	Dual stainless steel multi-jet spray tubes					
Blade Guard Attachment	Slip-on tapered spade (with rear bolt for 36" to 48" guard size)					
Blade Raise and Lower	Electro-hydraulic power unit with push button control					
Blade Lowering Speed	Adjustable in-line flow control valve					
Blade Depth Control	Electronic depth indicator and depth stop					
Blade Alignment	Telescoping front/rear/left/right pointers with tracking adjustment					
Axle Size (Front/Rear)	Front: 1" OD straight / Rear: 1" OD tapered					
Front Wheels	8" x 3" with 1/2" poly tread (sealed ball bearings)					
Rear Wheels	10" x 3" with 1" poly tread (quick disconnect lug nuts)					
Travel Speed	0-220 FPM (2.5 mph) forward/reverse					
Rear Wheel Transmission	Hydrostatic pump with push/pull cable control					
Rear Wheel Drive	Hydraulic wheel motors with freewheel for pushing					
Parking Brake	Automatic hydraulic lock at stop position					
Handle Bar Adjustment	Variable extension with quick lock variable 30° angle range					
Safety Alerts	Emergency stop, blade over-speed, neutral start					

*With blade guard and full fuel tank - no blade

CC7574DD-PRO-3 Specifications

Saw Model	CC7574DD-PRO-3-30	CC7574DD-PRO-3-36	CC7574DD-PRO-3-42	CC7574DD-PRO-3-48
Blade Guard Capacity	30"	36"	42"	48"
Blade Cutting Depth Max	12.25"	14.75"	17.25"	19.75"
Blade Shaft Speed	1800 rpm	1300 rpm	1200 rpm	1000 rpm
Blade Flange Size	5" OD	6" OD	7" OD	8" OD
Operating Weight*	2284 lbs.	2300 lbs.	2320 lbs.	2329 lbs.
Crated Weight	2384 lbs.	2400 lbs.	2420 lbs.	2429 lbs.
Blade Guard Weight Only	49 lbs.	63 lbs.	72 lbs.	94 lbs.
Engine Brand Model	Deutz TD 2.9 L4, EMR5			
Emission Regulation	EPA-CARB Tier 4 Final			
Engine Type	2.9 liter, 4 cylinder, liquid cooled, turbo diesel			
Engine Max Power	74.3hp @ 2600 rpm (Deutz rating)			
Engine Peak Torque	192 Ft-Lbs (260 Nm) @ 1600 rpm			
Aftertreatment Device	Diesel Oxidation Catalyst (DOC)			
Engine Air Filtration	Dry dual element with spinner pre-cleaner and restriction indicator			
Battery	12 Volt (800 CCA) group size 24			
Starter / Alternator	Electric 3.5hp (2.6kW) / 55 Amp, 14V			
Fuel Type	Ultra low sulfur diesel (Cetane 45 min)			
Fuel Tank	8.5 Gallon (32 Liter) with electronic low fuel level indication			
Engine Oil	SAE 15W-40 API class CJ-4 (8.5 Quarts/8.0 Liter)			
Radiator Coolant	50/50 Pre-mixed (3 Gallon/11.3 Liter)			
Wheel Motor Pump Fluid	SAE 15W-40 (2 Liter capacity)			
Saw Lift Pump Fluid	SAE 15W-40 (2 Liter capacity)			
Lubrication Type	NLGI #2 Lithium grease			
Blade Arbor Size	1" Diameter with drive pin			
Blade Flange Type	Quick disconnect			
Blade Shaft Size	45mm OD with left/right side blade mounting			
Blade Shaft Bearings	6 High precision ball bearings			
Blade Shaft Drive	20 V-Belts (3VX)			
Blade Coolant	Dual stainless steel multi-jet spray tubes			
Blade Guard Attachment	Slip-on tapered spade (with rear bolt for 36" to 48" guard size)			
Blade Raise and Lower	Electro-hydraulic power unit with push button control			
Blade Lowering Speed	Adjustable in-line flow control valve			
Blade Depth Control	Electronic depth indicator and depth stop			
Blade Alignment	Telescoping front/rear/left/right pointers with tracking adjustment			
Axle Size (Front/Rear)	Front: 1" OD straight / Rear: 1" OD tapered			
Front Wheels	8" x 3" with 1/2" poly tread (sealed ball bearings)			
Rear Wheels	10" x 3" with 1" poly tread (quick disconnect lug nuts)			
Travel Speed	0-220 FPM (2.5 mph) forward/reverse			
Rear Wheel Transmission	Hydrostatic pump with push/pull cable control			
Rear Wheel Drive	Hydraulic wheel motors with freewheel for pushing			
Parking Brake	Automatic hydraulic lock at stop position			
Handle Bar Adjustment	Variable extension with quick lock variable 30° angle range			
Safety Alerts	Emergency stop, blade over-speed, neutral start			

*With blade guard and full fuel tank - no blade

Safety Precautions

Safety

Operate the equipment and all of its components according to this manual. Failure to comply with and understand the following safety, operation and maintenance instructions can result in serious injuries and/or death. All operators must be properly trained or supervised by experienced personnel prior to using this saw and should understand the risks and hazards involved. Diamond Products discourages improper or unintended equipment usage and cannot be held liable for any resulting damages.

Equipment modifications should be made by Diamond Products to ensure safety and design. Any modifications made by the owner(s) are not the responsibility of Diamond Products and void all equipment warranties if a problem arises as a result of the modification.

Refer to the Diamond Products Parts List for additional information and part diagrams. Refer to the engine manual and manufacturer as the primary source for all safety, operations, and maintenance instructions regarding the engine. Prior to operating, record the saw's serial number, and the engine's model and serial numbers in Appendix D.

Notice: The information in this manual may be updated at any time!

Safety Alerts



DANGER

Serious injuries and/or death will occur if these instructions are not followed.



WARNING

Serious injuries and/or death could occur if these instructions are not followed.



CAUTION

Mild and/or moderate injuries could occur if these instructions are not followed.

Proposition 65

PROPOSITION 65



WARNING: This product produces gasoline or diesel engine exhaust, which is known to the state of California to cause cancer, birth defects or other reproductive harm. For more information go to:
WWW.P65WARNINGS.CA.GOV

Spark Arrester Requirement



WARNING

In the State of California it is a violation of section 4442 or 4443 to use or operate the engine on any forest-covered, brush-covered, or grass-covered land unless the engine is equipped with a spark arrester, as defined in section 4442, maintained in effective, working order or the engine is constructed, equipped, and maintained for the prevention of fire pursuant to section 4443.

Respiratory Hazards



WARNING

Concrete cutting produces dust and fumes known to cause illness, death, cancer, respiratory disease, birth defects, and/or other reproductive harm. Safety protection techniques include, but are not limited to:

- Wearing gloves.
- Wearing safety goggles or a face shield.
- Using approved respirators.
- Washing work clothes daily.
- Using water when wet cutting to minimize dust.
- Washing the hands and face prior to eating/drinking.

For additional safety and self-protection information contact your employer, the Occupational Safety and Health Administration (OSHA), and/or The National Institute for Occupational Safety and Health (NIOSH).

General Safety

- Read and understand all safety, operations, and maintenance instructions provided in this manual prior to operating or servicing the saw.
- Keep equipment components clean and free of slurry, concrete dust, and debris.
- Inspect water hoses prior to operating the equipment. Clean, repair, or replace damaged components.
- Raise the equipment to a proper height for access when working underneath the equipment. Use chocks to block the wheels, and fit blocks or jacks under the frame edges.



WARNING

Do NOT work on equipment using the hydraulic lift system to keep the equipment in the raised position for maintenance or repair. Accidental loss of hydraulic pressure could cause the equipment to drop suddenly, resulting in serious injury or death.

- When using a jack to raise the equipment, place the jack against a solid, flat area under the frame base to properly support the equipment.
- Repair the equipment immediately when a problem arises.
- Replace equipment decals if unreadable.
- Dispose of all hazardous waste materials according to city, state, and federal regulations.
- Always have a phone nearby, and locate the nearest fire extinguisher and first aid kit prior to operating the equipment.
- Operate the equipment wearing flame resistant clothing.
- Always wear safety glasses when removing retaining rings.
- Underage or non-trained personnel should not operate the equipment.
- Keep all body parts away from rotating machinery.
- Replace all guards and access panels (unless stated otherwise) prior to operating the equipment.
- Always pivot front of blade guard fully closed to avoid serious injuries.

DO NOT:

- Assume the equipment will remain still when in neutral or when parking/stopping the equipment on a slope. Chock the wheels to help prevent unnecessary movement.
- Drop equipment, supplies, tools, etc., when handling to help prevent injuries.
- Lift and carry equipment, supplies, tools, etc., that are too heavy and/or cannot be lifted easily.
- Operate the equipment without using the appropriate safety equipment required for the work task.



- Operate or service the equipment with any clothing, hair, or accessories that can snag in the machinery, which could lead to serious injuries or death!
- Operate the equipment using attachments not associated with or recommended for the equipment.
- Operate the equipment around combustible materials.
- Operate the equipment with anyone near the work area or within the direct line of the blade.
- Operate the equipment until all unnecessary materials have been removed from the work area.
- Operate the equipment with loose nuts, screws, and bolts.
- Operate the equipment when ill or fatigued.
- Operate the equipment under the influence of drugs and/or alcohol.
- Operate the equipment on steep slopes.
- Cut concrete with guards and access panels removed.
- Grease the equipment with the engine running.
- Touch hot components when operating the equipment.
- Leave the equipment unattended until the engine is off and the blade has stopped.
- Place the equipment into storage until it has cooled down.
- Service the equipment until it has cooled down.
- Service the equipment with the engine running.

Battery and Electrical Safety

- Ignitable explosive gases are emitted from the battery. DO NOT expose the battery to sparks or open flames. 
- Keep the area around the battery well-ventilated.
- Keep the battery level when handling it.
- Use protective eyewear or a face shield, and avoid contact with the skin when handling/servicing the battery.
- Use a proper battery tester when testing the battery strength.
- Always be sure to connect the battery cables to the proper terminal when reconnecting the cables.
- Occasionally inspect the battery, cables, clamps, and terminals for damages. Service components as necessary.
- Always keep the battery cable clamps away from the battery terminals when the battery is disconnected to avoid accidental connections while servicing.
- Immediately rinse your clothing, skin, or eyes with water if exposed to battery acid. Seek medical attention immediately!
- Disconnect the battery prior to servicing all equipment components (unless stated otherwise).
- Remove the battery when storing the equipment for longer periods.
- Always use the correct size fuses (amps) to prevent fires.

Blade Safety

- Always use reinforced abrasive blades or steel-centered diamond blades.
- Never use a wet cutting blade without an adequate water supply to properly lubricate the blade.
- Inspect all blades prior to usage and discard damaged blades.
- DO NOT install or remove a blade with the engine running.
- Keep all body parts away from rotating blades.
- Inspect the blade flanges for damages, wear, and cleanliness. Clean or replace dirty/damaged components immediately.

- DO NOT expose yourself or anyone else to the direct line of the blade when operating the equipment. 
- Always use an appropriate size blade and the correct blade type based on the cutting task and the type of material being cut.
- The blade must always fit snug on the blade shaft, outer flange, and/or inner flange.
- Wear gloves and be alert to the surrounding environment when handling blades.
- When installing the blade, always point the arrow printed on the blade in the direction of the blade shaft's rotation.
- DO NOT exceed the blade's maximum recommended speed when cutting. Excessive blade speeds can cause blade breakage, resulting in serious injuries and/or death!
- DO NOT use damaged blades when cutting to avoid harming yourself, others, or the equipment.
- DO NOT use a blade for cutting that requires a lower speed than the blade shaft speed.
- Always tighten the blade shaft bolt/screw as directed to properly secure the outer flange and blade. Failure to properly secure the outer flange and blade may cause parts to loosen or fall off the equipment, resulting in serious injuries or death!
- Let the blade cool prior to removal when dry cutting (applicable models).

Blade Guard Safety

- DO NOT operate the equipment with the blade guard raised or removed.
- Blade exposure should not exceed 180° while cutting.
- When pivoting the front of the blade guard, raise/lower it cautiously and slowly to avoid serious injuries.
- DO NOT pivot the blade guard front up or down when installing/removing very large blades. Attempting to pivot the front of a heavy guard when the guard is positioned higher up for blade installation/removal makes the guard difficult to lift and/or lower. In this situation, install/remove the blade guard front instead of pivoting it.



- Always pivot the front of the blade guard 180° (fully upward) so the guard does not swing down unexpectedly, causing serious injuries. 
- Always secure the pivoted section of the blade guard using the detent pin (guards 26" and up).
- Use extreme caution when installing/removing parts of a guard or the entire guard as guards can be extremely heavy and may require installation/removal at moderate heights.
- DO NOT install or remove the blade guard with the engine running.
- Always use a blade guard that corresponds with the blade size.
- Inspect the blade guard and water tubes prior to starting the equipment. Clean or replace dirty/damaged components immediately.

Fuel Safety

- Always use caution when refueling.
- Store all fuel in appropriate safety containers.
- DO NOT operate the equipment with a fuel leak.
- DO NOT fuel the equipment with the engine running.
- Let the engine cool prior to adding fuel.
- Refer to the engine manual for recommended fuels.
- Always use appropriate fuels in cold weather.
- Move the equipment away from the refueling area prior to starting the engine.
- DO NOT smoke or expose fuel to open flames when filling the fuel tank or working with fuel. 
- Clean up any spilled fuel prior to starting the engine.
- Drain the fuel tank and fuel lines when storing the equipment for longer periods of time. Refer to the engine manual for additional recommendations.

Engine Safety

- Refer to the engine manual as the primary source for engine safety.

- Always know how to turn off the engine quickly for emergency purposes.
- Make sure the equipment is in neutral when starting the engine.
- Fill the fuel tank and check the oil level prior to starting the engine.
- Keep all body parts away from rotating equipment parts with the engine in operation. 
- DO NOT start the engine without the air filter(s) installed.
- DO NOT allow dust to enter the air intake tube when cleaning/replacing air filter(s).
- Replace damaged components immediately that may allow dust to enter the engine.
- DO NOT leave the engine running unattended.
- Always operate the equipment in well-ventilated areas. Concentrated engine exhaust can cause loss of consciousness and/or death. 
- DO NOT touch the engine/muffler assembly with the engine running, and always let them cool down prior to touching or servicing the equipment.
- Handle hot oil carefully when changing the oil.
- Let the engine cool prior to removing pressurized caps (applicable models).
- DO NOT use any starter substances or starter fluids (e.g., starter fluid sprayed into the air filter) when starting the engine using a glow plug (applicable models). These materials are extremely flammable and explosive, and can melt parts or possibly explode when used to help start the engine.

Cutting Safety

- The direct work area should not contain buried or embedded electrical, gas, or water lines that could be damaged and/or cause personal injury while cutting.
- Turn off all electricity, gas, and water around the direct work area prior to cutting.
- Inspect the work area to ensure nothing will impede full control of the machine at all times.

- DO NOT expose yourself or anyone else to the direct line of the blade when operating the equipment.
- DO NOT allow any person, animal, and/or objects in and around the work area while cutting.
- DO NOT install a blade on the machine until it is in the cutting area.
- Ensure the work area is adequately illuminated to ensure safe operation of the machine.

Hydraulic Safety

- Turn off the engine prior to servicing hydraulic components.
- Lower the equipment completely prior to servicing to decrease the hydraulic pressure in the lines.
- Always make sure any hydraulic components being serviced are not supporting the weight of other equipment components. If a particular component is under pressure when connection points are loosened, oil may spray out forcefully.
- Always place a piece of cardboard or paper up against hydraulic components, or use a leak detection fluid to check for hydraulic fluid leaks. Keep all body parts away from leaks and/or areas that may eject hydraulic fluid. Pressurized hydraulic fluid can penetrate the skin, causing serious injuries. Seek medical attention immediately!



Belt Safety

- Turn off the engine and let the belts cool down prior to servicing them.
- Regularly inspect the belts for fraying, stress cracks, and/or breakage and replace immediately when damaged. Always check the belt alignment prior to operating the equipment.
- Use extreme caution when working with belts and rotating machine parts to avoid entanglement.
- Over-tensioning belts may reduce the life of the gearbox bearings. Under-tensioning belts may cause slippage, shorter belt life, and/or poor equipment performance.
- Squealing belts indicate looseness.

- DO NOT use old and new belts together on the same sheave.

Transporting Safety

- Remove the blade prior to transporting the equipment.
- Make sure the truck/trailer is in good, working condition and sufficient to transport the load. DO NOT tow the equipment behind a vehicle.
- Close the fuel shutoff valve (applicable models) when transporting.
- Drain the fuel tank when transporting long distances.
- Use heavy-duty ramps that will support the weight of the equipment and yourself when loading or unloading.
- Raise the equipment to avoid damaging components while moving up and down ramps.
- Use extreme caution when guiding the equipment up and down ramps. Slowly drive the equipment forward down the ramp. Slowly back the equipment in reverse up the ramp. Avoid standing directly downhill from the equipment to prevent machine rollover.
- Place the equipment in neutral and turn off the engine once the equipment is loaded in the truck/trailer.
- Chock the wheels and secure the saw in the truck/trailer prior to transporting.
- Refer to the Department of Transportation (DOT) for additional transportation recommendations.



Lifting Safety

- Move yourself and others away from the lifting area when hoisting the saw to prevent being crushed.
- Secure the appropriate hoisting cables, straps, and/or chains to the saw's designated lift points prior to hoisting.
- Never use the tie-down brackets (applicable models) to lift the saw.
- DO NOT attempt to lift the saw irresponsibly and/or improperly.

Display Panel Controller

The display panel is a rugged Controller Area Network or CAN. This is a means of linking all of the electronic systems within the saw together allowing them to communicate with each other. This section explains the functions of the unit, describes the display screens and gives details about the configuration.

Controller Features



Flat Screen Display

The flat screen displays the gauges, dashboard warning icons, soft key commands, fault messages, and menu options for setup and configuration.

There are a series of eight digital gauges, four on the left side of the display and four on the right. These gauges display current parameters associated with the saw.

<u>Left Side</u>	<u>Right Side</u>
Blade Size	Blade Depth
Battery Voltage	Engine Oil Pressure
Engine Coolant Temperature	Blade Depth Stop Setting
Actual Engine Hours	

There is a large digital gauge located in the center of the display. This gauge can be toggled through using the function key associated with the “Parameter Selection Screen” to show blade speed, engine speed, and engine torque.



Blade Speed Indication





Engine Speed Indication



Engine Torque Indication

Directly above the large center gauge is the dashboard warning icon display area. When certain conditions arise, there are fifteen icons that will be displayed in this area.

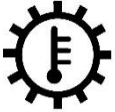
	Parking Brake - Green icon will illuminate when the hydraulic parking brake is applied.
	Fuel Level – Red icon will illuminate when a low fuel level condition exists.
	Water in Fuel – Red icon will illuminate if water is detected in the fuel tank.
	Battery Voltage – Red icon will illuminate when a low battery voltage condition exists.
	Maintenance Required – Yellow icon will illuminate when a required maintenance milestone is reached.
	Check Engine –Yellow icon will illuminate if the controller receives a DM1 message with a yellow lamp command. –Red icon will illuminate if the controller receives a DM1 message with a red lamp command.
	Oil Pressure – Red icon will illuminate when a low oil pressure condition exists.
	Coolant Temperature – Red icon will illuminate when a high engine coolant temperature condition exists.

	Low Coolant Level – Red icon will illuminate when a low coolant condition exists.
	Gearbox High Temperature – Red icon will illuminate when the gearbox temperature reaches 250° F (121° C)
	Clutch Engaged – Green icon will illuminate when the optional blade clutch is engaged.
	Neutral – Green icon will illuminate when the transmission is in neutral.

Directly below the large center gauge is a clock. This area will also display any active fault conditions associated with the saw.

Function Keys

When pressed, the function keys correspond to soft key commands and allow selections to be made accordingly. The soft key selections will appear at the bottom of the display.



Soft Key Commands

Soft Key Commands

A horizontal row of commands located at the bottom of the display screen can be selected by pressing the function key directly below it. The soft key options associated with this saw are listed below:

Soft Key	Description
	Blade Size – Toggles to the blade size selection screen
	Parameter Screen Selection – Toggles between Blade Speed, Engine Speed, and Engine Torque digital gauges
	Main Menu – Toggles to the Main Menu screen that provides three options: <ul style="list-style-type: none"> • Engine Diagnostics • User Settings • Utilities
	Zero Blade – Sets the reference point for the blade depth setting
	Blade Depth Stop (Inactive) – Sets the blade depth stop setting
	Blade Depth Stop (Set) – Blade depth stop setting is active

Soft Key	Description
✓	Select – Enters the action item highlighted on the screen
←	Left Arrow – Moves cursor to the left
→	Right Arrow – Moves the cursor to the right
↑	Up Arrow – Moves the cursor up
↓	Down Arrow – Moves the cursor down
+	Plus – Increases a numerical selection
-	Minus – Decreases a numerical selection
↶	Return – Returns to previous screen
↻	Reset – Resets the service reminder hours on maintenance milestones when the maintenance is completed
ⓘ	Fault Information – Provides additional information regarding active/stored faults

Main Menu Key

Pressing the **MENU** key displays the list of three available menu options:

- Engine Diagnostics
- User Settings
- Utilities



Engine Diagnostics

The engine diagnostics screen displays the following items:

1. Recall Active Faults
2. Stored Faults



Recall Active Faults

This screen displays active faults or warnings from the Electronic Control Unit (ECU). Each diagnostic is shown with the appropriate Suspect Parameter Number (SPN), Failure Mode Indicator (FMI), Text Description (if available) and the source of the device that transmitted the diagnostic message.



Stored Faults

This screen displays the non-active faults or warning from the ECU. Each diagnostic is shown with the appropriate Suspect Parameter Number (SPN), Failure Mode Indicator (FMI), Text Description (if available) and the source of the device that transmitted the diagnostic message.



User Settings

The user setting is a series of two screens that display the following items:

1. Brightness
2. Language
3. Units
4. Set Clock



Brightness

This option allows the operator to increase or decrease the intensity of the backlighting as needed to clearly view the display screen.

Language

This option allows the operator the ability to select the desired language utilized on the display. There are five languages choices:

- English
- Spanish
- French
- Italian
- German

Units

This option allows the operator to choose between standard (US) and metric units.

Set Clock

This option allows the operator to set and update (save setting) the time on the clock display. The clock will remain operational when the unit is turned off. Only when battery power has been lost will the clock need to be reset and updated.

Utilities

The utilities screen displays the following items:

1. Service Reminders
2. System Information
3. Lamp Information



Service Reminders

This option is a series of two screens that show the five critical service reminders with the time in hours when the next service is due to be completed. When a service item is completed the time can be reset for the next service schedule. See the maintenance section of this manual for additional information regarding maintenance schedules.



System Information

The system information screen is informational only. The screen displays the following settings:

1. Engine Make
2. Engine Model
3. Engine Serial Number
4. Rated Power
5. Rated Speed
6. Software Revision



Operation

Blade Size Selection

When the ignition switch is turned to ON, the display will begin to boot up. The first screen to appear will be the "Blade Size Selection" screen. It is extremely important to have the correct blade size selected for the installed blade on the machine. Not having the proper blade size selected for the installed blade will result in reduced cutting efficiency and/or serious bodily injury! Refer to the RPM and Blade Size Conversion Charts located in Appendix B at the end of this manual.



To select the proper blade size:

1. Scroll through the available blade sizes using the function keys associated with the right and left arrow soft key commands located on the lower right side of the display panel.
2. When the proper size appears on the screen, press the select function key (middle key) to accept the blade size and this will bring up the “Home” screen.

The blade size can also be selected from the “Home” screen by pressing the left function key associated with the “Blade Size” soft key command. When the key is pressed the “Blade Size Selection” screen will appear.

Blade Speed

It is imperative to select the correct blade size for the installed drive configuration of the machine. The display shows the actual blade shaft speed that is being output by the shaft tach gear assembly. The blade speed limit is based on the blade size selected by the operator and is programmed into the controller to prevent an over-speed condition with the blade. If the tach gear sensor is lost, the blade shaft speed limit will be based on the factory set engine speed for the blade size setup originally ordered.

Zero the Blade

Ensure that the saw is operating and all safety precautions are being followed.

1. Lower the saw blade to just above the cutting surface.
2. Press the second function key on the right twice until the top right hand gauge on the display shows 0.00 in.



The blade is now zeroed. When the blade is lowered into the cut, the gauge will increase incrementally in the selected units (inches or millimeters) to show the depth of the cut.

Set the Blade Depth Stop

Ensure that the saw is operating and all safety precautions are being followed.

1. Follow the “Zero the Blade” procedure listed above.
2. Lower the blade into the cut to the desired depth.
3. Press the function key farthest right on the display panel twice until “Depth Stop Active” appears at the bottom of the display screen and the depth setting appears on the lower right hand gauge.

Deactivate the Blade Depth Stop Setting

To deactivate the “Blade Depth Stop” setting, press the function key farthest right twice until the lower right hand gauge shows 0.00.

Operating

For additional information and detailed diagrams on individual saw components, refer to the CC7574DD-PRO Parts List in conjunction with this manual.

Tie-Downs

Use the tie-downs when securing the saw in a truck/trailer for transportation:

- D-ring on back of saw
- (2) skid plates or (1) eyebolt on front of saw

DO NOT over-tighten a chain/rope to the front end tie-downs, which may bend the frame and damage the saw.

Footrest

Use the footrest, if desired, to add body weight to the rear of the saw and improve the rear wheel traction when cutting.



Footrest

Weight Bar (Optional)

The weight bar (optional) adds 56 Lbs. to the saw to improve the rear wheel traction when cutting.

Note: The weight bar is a standard feature on the 48" blade saw.

1. Attach the second footrest to the back of the frame base using the screws, washers, and lock nuts provided.
2. Rest the weight bar on top of both footrests.
3. Place a flat washer onto both screws. Fit the screws through the screw holes on top of the weight bar and through the slot on both footrests.

4. Install a fender washer onto each screw underneath the footrest and secure with a lock nut.
5. Remove the weight bar as necessary.

Spotlight

1. Loosen both spotlight bar lock knobs and slide the spotlight bar from side-to-side to adjust the length of the bar.
2. Tighten the lock knobs to secure.
3. Turn the spotlight switch on or off as needed for additional lighting.

Handlebars

The handlebars help to guide and maneuver the saw. Place the handlebars in the desired position for better leverage when lifting and steering. To maneuver the saw forward or backward, turn on the *Free Wheel* switch and move the saw as desired (the free wheel component only works with the ignition key at ON).

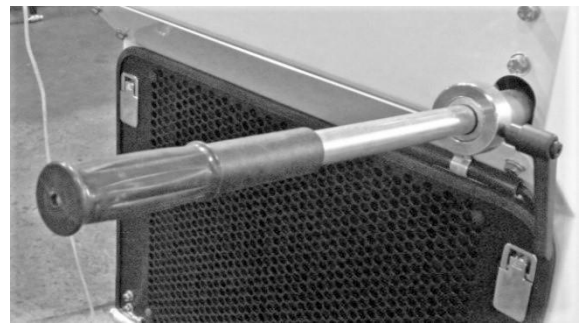

Handlebar

Adjusting the Handlebars

1. Loosen the handlebar adjusting lever.
2. Move the handlebar forward or backward to adjust the length and retighten the adjusting lever to secure.
3. Press the *Tilt Handlebar* pushbutton, located on the side of the control grip, and move the handlebar up or down to adjust the angle.

Note: The button only works with the ignition key at the ON position.

4. To reposition adjustment lever, pull out and move to desired lever position.

Control Grip Pushbuttons

The control grip pushbuttons only work with the ignition key at *ON* or with the engine running.



Control Grip Pushbuttons

1. Press the *Raise* (left) pushbutton to raise the saw and blade, and release to stop.

Note: Always raise the blade when maneuvering the saw to provide proper clearance between the blade and the ground.

2. Press the *Lower* (right) pushbutton to lower the saw and blade, and release to stop.
3. Press the *Tilt Handlebar* pushbutton, located on the side of the control grip, and move the handlebar up or down to adjust the angle.

Fuel System

! WARNING

- Always use caution when refueling
- DO NOT operate the saw with a fuel leak
- DO NOT fuel the saw with the engine running
- DO NOT smoke or expose fuel to open flames when filling the fuel tank or working with fuel



! CAUTION

- Clean up any spilled fuel prior to starting the engine.
- Fuel may seep out from the fuel cap vent (applicable models) when raising the saw if the fuel tank is overfilled.

Adding Fuel

1. Lower the saw to level the frame.
2. Turn off the engine and let the saw cool down.
3. Remove the fuel tank cap.
4. Fill the fuel tank with ultra-low sulfur diesel fuel. DO NOT overfill the tank for expansion purposes. Refer to the engine manual for information on appropriate diesel fuels in normal and cold weather temperatures,
5. Replace the fuel tank cap and secure.

Blade Guard

! WARNING

- DO NOT operate the saw with the blade guard raised or removed.
- DO NOT remove the blade guard with the engine running.
- Blade exposure should not exceed 180° while cutting.
- Always pivot the front of the blade guard 180° (fully upward) so the guard does not swing down unexpectedly, which may cause serious injuries.
- Always secure the pivoted section of the blade guard using the detent pin (guards 26" and up)
- When pivoting the front of the blade guard, raise/lower it cautiously and slowly to avoid serious injuries.



The blade guard shields the blade and must always be in place when operating the saw. Blade guards generally stay in place at all times, except for when changing to another guard size or when using the guard on the opposite side of the saw. Regularly inspect the blade guard and water tubes. Clean, repair, or replace dirty or damaged components immediately.

Note: Always use a guard size that matches the blade size. Refer to the parts list for additional information.

Installing the Blade Guard

Always install the blade guard with the blade off the saw.

1. Holding the blade guard handle, face the front of the blade guard forward and fit the tapered mount on the side of the guard onto the tapered mount on the frame.



Frame Base Mount

2. Insert the lock pin through the hole on the tapered frame mount to secure the guard.
3. For guards 36" and up, raise the saw slightly. Place a lock washer and then a flat washer onto the blade guard screw. Fit the screw through the slot near the back of the guard and through the hole on the frame base, and secure the guard to the frame using the provided wrench.
4. Connect the water supply hose to the blade guard.

Removing the Blade Guard

Always remove the blade guard with the blade off the saw.

1. Disconnect the water supply hose from the blade guard.
2. For guards 36" and up, raise the saw slightly. Remove the screw from the frame base and blade guard.
3. Remove the lock pin from the tapered frame mount.
4. Use the handle on the blade guard to rock the guard back and forth while lifting the guard off the tapered frame mount.

Flange Guard

Install the flange guard over the blade flange that is not in use.

Installing the Flange Guard

1. Fit the tapered mount on the back of the flange guard onto the tapered mount on the frame.
2. Insert the lock pin through the hole on the tapered frame mount to secure the guard.



Flange Guard Installed

Removing the Flange Guard

1. Remove the lock pin from the tapered frame mount.
2. Remove the flange guard from the tapered frame mount.

Diamond Blades



WARNING

- DO NOT exceed the blade's maximum recommended speed when cutting. Excessive blade speeds can cause blades breakage, resulting in serious injury or death.
- DO NOT use damaged blades when cutting to avoid harming yourself, others, or the saw.

Using the proper blade (size and type) preserves the blade and improves efficiency, resulting in lower costs. Refer to the Association of Equipment Manufacturers (AEM) safety brochure for diamond blades and www.diamondproducts.com for additional blade information.

Inspecting the Blade

Inspect each blade prior to installation and discard all damaged blades. Inspect the blades for:

- Cracks, nicks, and dents
- A damaged/deformed arbor (center hole)
- Darkness/discoloration near edge of blade
- A deformed blade circumference
- Segment loss/cracks
- Core wear
- Bending
- Uneven side-widths

Blade Speed

Refer to the CC7574DD-PRO RPM Chart, the blade, or the blade packaging information for the recommended blade speeds when cutting. DO NOT exceed the maximum recommended blade speed. DO NOT use a blade for cutting that requires a lower speed than the minimum blade shaft speed.

Wrench

A 15/16" combination wrench, located on the right side of the control panel, is provided for installing or removing a blade. Apply force to the opposite end of the wrench and tighten the blade shaft bolt/screw to 125 ft-lb (170 Nm) minimum to secure the outer flange and blade.

Note: 125 ft-lb is equivalent to applying 125 pounds at the end of a 12" wrench.

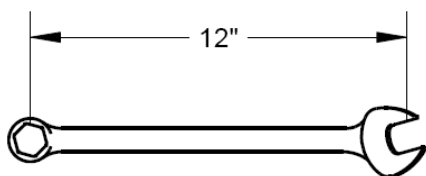

Combination Wrench

A two head open end wrench, with 1-1/16" and 1-1/8" ends, located on the inside of the left side door of the saw, is provided for the vertical jack bolts to adjust the blade drive belt tension.



Two Head Open End Wrench

Installing the Blade

CAUTION

- Wear gloves and be alert to the surrounding environment when handling blades.

WARNING

- DO NOT install a blade with the engine running.
- Failure to secure the outer flange and blade may cause parts to loosen or fall off the saw resulting in serious injury or death.
- DO NOT pivot the front blade guard up or down when installing very large blades. Attempting to pivot the front of a heavy guard when the guard is positioned higher up for blade installation makes the guard difficult to lift and/or lower. In this situation, remove the front blade guard instead of pivoting it.
- Always secure the pivoted section of the blade guard using the detent pin (guards 26" and up).

The blade can be installed on the right or left side of the saw. Install the blade on the side preferred or most appropriate for the cutting task.

1. Select a blade size and type. Remember to check the blade for damages and discard as necessary.

Note: If changing the blade size, adjust and/or change all necessary saw components according to the information in the CC7574DD-PRO Parts List.

2. Remove the detent pin (guards 26" and up) from the guard hinge and pivot the front of the blade guard 180° (fully upward) to gain access to the blade flanges. For larger, heavier guards that are positioned too high up and are unsafe to pivot, remove the lock nut and screw from the center of the guard hinge. Remove the front of the guard.

Note: Have a second trained operator hold the guard in place while removing the hinge screw and nut.

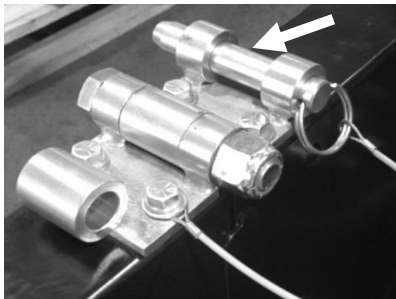

Detent Pin

3. On the pivoted guards, insert the detent pin through the interlocking barrels on the top of the guard to secure the front of the guard.

Note: Failure to fully pivot and secure the front of the guard may cause serious injuries.

4. Remove the blade shaft bolt. Note: clockwise loosens on right side, counterclockwise loosens on left side (when viewed from the operating position) using the provided wrench located on the right side of the control panel.
5. Carefully remove the outer flange. Inspect the flange assembly and clean or replace dirty/damaged components.
6. Place the blade against the inner flange. For large blades, carefully roll the blade up to the inner flange. Adjust the height of the saw to align the flange and blade arbor.

Note: Point the arrow printed on the blade in the direction of the blade shaft's rotation.

7. Align and fit the outer flange and flange pin through the blade and into the inner flange and blade shaft.

Note: The outer flange should fit snug with the blade, inner flange, and blade shaft.

8. Slightly rotate the outer flange and blade backward to eliminate backlash (looseness) between parts.
9. Place the wedge lock washer onto the blade shaft screw and insert the screw into the blade shaft through the center of the outer flange.
10. Tighten the screw by hand. Slowly lower the saw, if necessary, until the blade just touches the ground.
11. Tighten the screw again, using the wrench, to 125 ft-lb (170 Nm) minimum to secure the outer flange and blade.

12. Remove the detent pin (guards 26" and up) from the guard hinge and pivot the front of the guard down over the blade to secure.
13. Re-insert the detent pin.

Removing the Blade

CAUTION

- DO NOT remove a blade with the engine running.
- DO NOT pivot the front of the blade guard up or down when removing very large blades. Attempting to pivot the front of a heavy guard when the guard is positioned higher up for blade removal makes the guard difficult to lift and/or lower. In this situation, remove the blade guard front instead of pivoting it.
- Always secure the pivoted section of the blade guard using the detent pin (guards 26" and up).



1. Remove the detent pin (guards 26" and up) from the guard hinge and pivot the front of the blade guard 180° (fully upward) to gain access to the blade. For larger, heavier guards that are positioned too high up and are unsafe to pivot, remove the lock nut and screw from the center of the guard hinge. Remove the front of the guard.

Note: Have a second trained operator hold the guard in place while removing the hinge screw and nut.

2. On the pivoted guards, insert the detent pin through the interlocking barrels on the top of the guard to secure the front of the guard.

Note: Failure to fully pivot and secure the front of the guard may cause serious injuries.

3. Slowly lower the saw, if necessary, until the blade just touches the ground.
4. Remove the blade shaft screw using the wrench located on the right side of the control panel.
5. Carefully remove the outer flange and blade. Place the blade in an appropriate storage location.

Note: If the outer flange is difficult to remove, tighten a setscrew into two of the holes on the outer flange to help separate the outer flange from the blade.

6. Inspect the flange assembly and clean or replace dirty/damaged components.
7. Carefully fit the outer flange back into the inner flange and/or blade shaft.
8. Place the wedge lock washer onto the blade shaft screw and insert the screw into the blade shaft through the center of the outer flange.
9. Retighten the blade shaft screw to secure the flanges.
10. Remove the detent pin (guards 26" and up) from the guard hinge and pivot the front of the guard down over the blade flanges to secure.
11. Re-insert the detent pin.

Engine



WARNING

Operate the saw in well-ventilated areas. Concentrated engine exhaust can cause loss of consciousness and/or death.

DO NOT touch the engine/muffler with the engine running, and always let them cool down prior to touching or servicing the saw.

DO NOT leave the saw unattended while the engine is running.



Tasks Prior to Starting the Engine

Complete the tasks listed below prior to starting the engine to ensure a safe start:

- Check fluids and fill to appropriate levels.
- Turn off controls and switches.
- Remove tools from area.

The engine **will not** start unless the following tasks are completed:

- Place speed control lever to the **STOP/PARK** position.
- Pull up emergency stop button.
- All emergency stop triggers are cleared:
 - 1) E-Stop active
 - 2) Low coolant level
 - 3) Radiator door open

Starting the Engine

Notice: In an emergency, press the emergency stop button to immediately stop the engine and any saw movement!

1. Insert the key into the ignition and turn it to the **ON** position and wait for the display screen to energize.

NOTE: While the display screen is energizing, the glow plug is preheating. If the glow plug requires more preheat time the following pop-up message will appear: "Wait to start, preheating".

2. Once the display screen is energized and there are no pop-up messages, turn the key to the **START** position and release when the engine starts.

NOTE: If the engine does not start within 10 seconds, turn off the key and try again approximately 30 seconds later. Refer to the engine manual for troubleshooting recommendations after several failed attempts.

3. Let the engine warm up. Check all warning lights and turn off the engine immediately if there are any problems prior to operating the saw.
4. Increase/decrease the engine/blade speed by pressing the throttle switch up or down as needed.

Stopping the Engine



CAUTION

- DO NOT leave the saw unattended until the engine is off and the blade has stopped spinning.

1. Place the speed control lever at **Stop** and raise the blade from the cut.
2. Turn off all controls, switches, and water.
3. Decrease the engine speed to idle for five minutes to cool down the engine after full load operation.
4. Turn the ignition key to **Stop** and remove the key.

Speed Control Lever

The speed control lever moves the saw forward and backward at up to 250 ft/min.

Note: The engine must be running at half throttle or greater to move the saw using the speed control lever.



Speed Control Lever

1. Slowly push the lever toward *Forward* to move the saw forward and release when at the desired traveling speed.
2. Slowly pull the lever toward *Reverse* to move the saw backward and release when at the desired traveling speed.
3. Place the lever at *Stop* to put the saw in neutral. DO NOT assume at any time that the neutral position will act as a brake when saw is running.

Note: Always start the engine with the speed control lever at Stop.

Blade Lowering Speed

Turn the blade lowering speed valve counter-clockwise to increase the blade's lowering speed and clockwise to decrease the blade's lowering speed.

Note: The valve does not adjust the blade's raising speed.

The valve is located by the hydraulic pump. To access, open the saw's right side door panel.



Blade Lowering Speed Valve

Water Supply

The water supply minimizes dust when cutting and cools the fuel, gearbox, and blade.

Note: Always test the water supply for adequate pressure and flow prior to cutting.

Using the Water Supply

1. Ensure the water valves on the right and left side of the saw are shut.
2. Connect the water source hose to the water valve fitting on the left side of the saw.
3. Check the following supply hose connections to ensure they are tight:
 - Supply hose from the right side water valve to the inlet of the fuel cooler assembly.
 - Supply hose from the discharge of the fuel cooler assembly to the inlet of the water solenoid valve.
 - Supply hose from the discharge of the water solenoid valve to the inlet of the gearbox.
 - Supply hose from the discharge of the gearbox.
4. Connect water supply hose from the discharge of the gearbox to the water manifold on the blade guard.
5. Move the water valve lever on right side of saw to full open. Increase or decrease water flow by moving the valve lever on the left side of the saw connected to the source hose.

Note: water on/off operation and flow adjustment can be made from either side of saw, if desired.

6. When finished cutting, shut off water supply to the blade guard, shut off water supply at source and remove source hose from the saw.
7. Drain water from upper gearbox heat sink. (*ref. maintenance instructions: upper gearbox*).

Water Pump (Optional)

The optional water pump directs water from the water metering control valve to the saw blade.

1. Ensure all water supply lines are connected.
2. Ensure that the water valves on the right and left side of the saw are shut.
3. Turn on the water pump switch to start the pump.

NOTE: DO NOT start the water pump until just before cutting. DO NOT leave the water pump on when the cutting task is complete to avoid draining the battery.

4. Move the water valve lever on the right side of the saw to the fully open position.
5. Increase or decrease water flow by adjusting the left side water valve lever.
6. When cutting is complete, shut both water valves.
7. Turn the water pump switch to *OFF* to stop the pump.

Automatic Water System (AWS)

The automatic water system provides a solenoid in the water supply system that works in conjunction with the “Zero Blade” option on the control panel. When the saw blade is “zeroed” at the pavement surface, the solenoid valve will allow water to flow when the blade is lowered into a cut. When the blade is raised out of the cut and the blade passes the “zero” point, the water flow will automatically shut off.

NOTE: When using AWS, adjust the water valve lever to meter the water flow. AWS will automatically turn the water on/off when the blade enters or exits the cut.

Cutting Guides

Use the cutting guides as needed to help follow the cutting line. Always check the cutting guides for proper alignment with the blade prior to cutting.

Adjusting the Front Pointer

1. Remove the lanyard from the cable cleat.
2. Lower the front pointer frame to the ground.
3. Loosen both front pointer frame screws.
4. Divide an 8–10 ft piece of string in half.
5. Place the looped end of string into a gullet on the backside of the blade.
6. Place one string line up against the backside of the blade and one string line up against the front side of the blade. Holding the string ends in one hand, tension the lines out toward the front pointer rod.

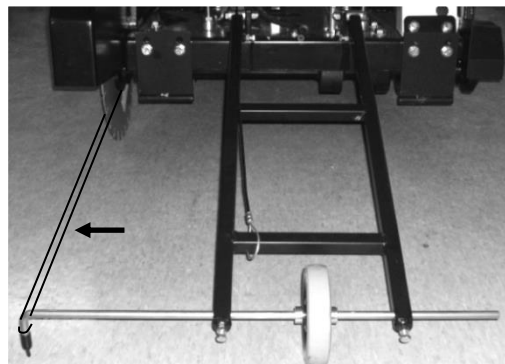

Tensioned String Line

7. Adjust the pointer rod to place the tip between the tensioned string lines.
8. Retighten both front pointer frame screws.
9. Lift the frame off the ground when finished.
10. Tension the lanyard and secure it to the cable cleat.

Adjusting the Rear Pointer(s)

1. Loosen the rear pointer nut and screw on the back of the frame base.
2. Adjust the orientation of the rear pointer rod and retighten the screw and nut to secure.

Concrete Cutting



WARNING

- DO NOT expose yourself or anyone else to the direct line of the blade while operating the saw.
- The direct work area should not contain buried or embedded electrical, gas, or water lines that could be damaged and/or cause personal injury or death.

Note: Always raise the blade to provide proper clearance between the blade and the ground when maneuvering the saw.

Helpful Hints Prior to Cutting

Keep the following in mind for better efficiency while cutting:

- Use just enough handle pressure to guide the saw down the cutting line. DO NOT forcibly direct (twist) the saw from side to side when cutting. DO NOT jam, cock, or wedge the blade in a cut.
- Moving too quickly when cutting may stall the saw, or may cause the blade to climb out from the cut. If the saw stalls while cutting, put the saw in neutral and raise the blade from the cut to restart the engine.
- Avoid sawing excessively deep to preserve the blade and reduce sawing costs.
- DO NOT lower the blade too quickly or move the saw forward too quickly when finishing a partial-cut to avoid forcing the blade into the concrete.
- Always have a proper water flow when cutting for maximum blade efficiency. Using too much water when cutting will make the slurry look clear. Not using enough water will make the slurry look thick and pasty.
- Refer to the Diamond Products' Guide for Professional Concrete Cutters for additional cutting tips and information.

Tasks Prior to Cutting

Complete the following tasks prior to cutting:

- Align the cutting guide(s) with the blade.
- Clearly mark the cutting line.
- Turn off all electricity, gas, and water around the direct work area.

Making a Cut

1. Align the blade and cutting guide(s) with the cut line.
2. Start the engine and allow to idle briefly before going to full power.
3. If the saw is equipped with a clutch (optional), turn on the *Blade Clutch* switch with engine at idle to start the blade rotation.
4. Turn on the water.
5. Move the lever on the right side water valve to the fully open position.
6. Adjust the water flow using the left side water valve.
7. Lower the blade to just above the cutting surface and zero the blade by pressing the "Zero Blade" button on the display panel.
8. Slowly lower the blade into the surface to no more than 2" deep. Make the initial pass across the entire cutting line using the most effective travel speed. If the blade is coming up out of the cut, decrease travel speed and/or feed depth. **DO NOT CUT FULL DEPTH IN ONE PASS.**
9. If you are cutting more than 2" deep, you can finish the job in less time and effort by step cutting. Cut a 2" depth on the initial pass, followed by deeper passes. On repeated passes, the blade will tend to follow the previous cut.
10. Raise the blade out of the cut and reposition the saw at the start of the cut line. DO NOT move backwards with the blade in a previous cut.
11. At the start of the cut line, lower the blade back into the cut and make a second, deeper pass across the entire cutting line.
12. Continue the step-cut process to reach the maximum depth. DO NOT cut any deeper than required.

Making a Cut Using the Blade Depth Stop

1. Align the blade and cutting guide(s) with the cut line.
2. Start the engine and allow to idle briefly before going to full power.

3. If the saw is equipped with a clutch (optional), turn on the *Blade Clutch* switch with engine at idle to start the blade rotation.
4. Turn on the water.
5. Move the lever on the right side water valve to the fully open position.
6. Adjust the water flow using the left side water valve.
7. Lower the blade to just above the cutting surface and zero the blade by pressing the "Zero Blade" button on the display panel.
8. Slowly lower the blade into the surface to no more than 2" deep.
9. Press the function key farthest right on the display panel twice until "Depth Stop Active" appears at the bottom of the display screen and the depth setting appears on the lower right hand gauge.
10. Continue with the first cut.
11. Raise the blade out of the cut and reposition the saw at the start of the cut. DO NOT move backwards with the blade in a previous cut.
12. Press the function key farthest right on the display panel twice to turn the depth stop off. Lower the blade down to the new desired depth and repeat step 8.
13. Continue the step-cut process using the depth stop to reach the maximum depth. DO NOT cut any deeper than required.

Continuing a Partial Cut

1. Maneuver the saw to the start of the cut line.
2. Align the blade with the previous cut and slowly lower the blade back into the concrete. Use extreme caution to make sure the blade is perfectly aligned within the cut. DO NOT continue cutting until the blade is aligned within the cut!
3. Continue the step-cut process (using the blade depth stop if preferred) to reach the maximum depth. DO NOT cut any deeper than required.

Finishing a Cut

1. Place the speed control lever at *Stop*.
2. Raise the blade from the cut (provide proper ground clearance).
3. If the saw is equipped with a clutch (optional), turn off the *Blade Clutch* switch

with engine at idle to stop the blade rotation.

4. Turn off the water supply.

Hood Operation

1. Pull up and out on rubber latch located on lower front of hood.
2. Grasp bottom of hood firmly and lift upwards.

Shifting the Three Speed Transmission

 **CAUTION**

- DO NOT attempt to shift the transmission while the engine is running.

1. Stop engine.
2. Lift hood by pulling up and out on rubber latch located on lower front of hood.
3. Grasp bottom of hood firmly and lift upwards.



Hood

4. Lift and hold shift lever while rotating the blade flange back and forth with the combination wrench located on the right side of the control panel.



Shift Lever

5. Slide shift lever over the desired slot in shift gate (from left to right Medium, Low, Neutral, and High, marked M, L, N, and H).

Note: You will need to rotate the output shaft BY HAND to complete this motion.

6. Drop shift lever into desired shift gate slot.

Maintenance

General

Failure to read and comply with the maintenance instructions provided in this manual prior to performing maintenance may harm the saw and/or result in serious injuries and/or death. DO NOT attempt to perform maintenance on the saw if you are not properly trained for it, or are not supervised by an experienced person.

Refer to the CC7574DD-PRO Parts List for additional information and part diagrams when performing maintenance tasks. Refer to the engine manual and manufacturer as the primary source for all safety, operations, and maintenance instructions for the engine. Contact the saw and/or engine manufacturer with any additional questions.

Remove all necessary guards and access panels prior to servicing the saw. Replace prior to operating.

Maintenance Tools

Tools critical for the maintenance of the machine are provided with the machine. A wrench holder tube is provided on the control panel that contains a 15/16" combination wrench for installing and removing blades. A two head open end wrench, with 1-1/16" and 1-1/8" ends, located on the left side of the saw near the gearbox expansion tank, is provided for the vertical jack bolts to adjust the blade drive belt tension. A 3/8" hex head L-Key is provided on back of the upright to adjust the speed control lever tension.

Pre-Maintenance Preparations

- Ensure the saw is in a safe area to conduct maintenance.
- Maintain proper cleanliness of the work area to minimize personnel injury or equipment damage.
- Ensure the saw is sufficiently cool to conduct any maintenance.
- Remove the cutting blade prior to starting any maintenance.
- Place the saw on a level surface with the engine turned off and the emergency stop activated.

- Ensure there is adequate lighting in the work area to ensure safety.
- Ensure all equipment and tools required for the maintenance task are staged and available for use.
- Prior to any maintenance being performed, know the locations of all safety equipment such as fire extinguishers, first aid kits, etc.
- All maintenance shall be performed by qualified personnel only.

General Cleaning

The saw must be cleaned after each use and prior to conducting any maintenance. Ensure that the saw is cool prior to cleaning. Ensure affected electrical equipment is properly covered or de-energized prior to cleaning with water or air.

Cleaning Techniques

Various cleaning options can be utilized depending on the type of cleaning required. High pressure washers and a mild detergent will work the best. Compressed air and low pressure water can also be utilized where required.



CAUTION

Care must be taken when using high pressure water and compressed air to conduct any maintenance or cleaning. High pressure water and compressed air can cause injury to personnel or damage to equipment if not used properly.

Radiator

Ensure that the radiator is cool prior to cleaning. Use a mild detergent with a wide fan setting on a pressure washer to remove grease and slurry from the radiator being sure to keep the wand far enough from the radiator to prevent damaging the fins.

NOTE: Damaged radiator fins can and will diminish the cooling capacity of the radiator.

Control Panel

Do not spray water on the control panel to clean. Use a damp cloth or compressed air to clean electrical components. Dry the control panel after cleaning.

Display Screen and Camera Lens

Do not spray water on the display screen to clean. Use a damp cloth to wipe it clean and dry the screen with a lint free cloth.

Engine

Use a mild detergent and water to clean the engine. Do not spray water forcefully on the engine to prevent damage to components.

NOTE: Do not spray water into the exhaust pipe or air filter.

Part Lubrication

 **WARNING**
DO NOT grease parts with the engine running.



Lubricate all necessary parts on schedule for maximum saw efficiency. Occasionally lubricate controls, cables, hinges, latches, and linkages with a spray lubricant when movement becomes stiff and/or sluggish. Use one to two full pumps of NLGI No. 2 premium, lithium-based grease when lubricating all grease fittings.

NOTE: Use more grease on bearing grease fittings if they are too hot to touch after completing work.

Post Cleaning

- Lubricate the machine as required.
- Dry all electrical components using compressed air.
- Do not start the machine until it has had time to thoroughly dry.

Service Schedule

The service schedule is based primarily on the standard operating time of the machine. The frequency of the maintenance tasks can be increased based on the working environments of the machine.

	Daily	50	100	250	500	1000	1500
Visually inspect saw for damage and repair as necessary	X						
Wipe down and clean all components for dust, debris, and slurry	X						
Check that all safety guards are in place and in good operating condition	X						
Check for loose or frayed wiring. Repair/replace as necessary	X						
Check for loose nuts and bolts and retighten as necessary	X						
Inspect all hoses for damage, leaks, or looseness and repair/replace as necessary	X						
Inspect all belts for tension or wear and re-tension or replace as necessary	X						
Check engine oil level	X						
Check fuel level	X						
Check hydraulic fluid level	X						
Check radiator coolant level	X						
Check and clean blade guard water spray tubes	X						
Check air cleaner restriction indicator	X						
Drain the upper gearbox heat sink (Cold weather only)	X						
Drain water from fuel/water separator filter		X ¹					
Lubricate hydraulic cylinder pivot pin		X					
Lubricate front axle pivot bearings		X					
Lubricate bogie wheel		X					
Replace the upper gearbox oil			X ²				
Replace the Lower gearbox oil			X ²				
Clean the in-line oil suction filter			X				
Check and clean the water system inlet strainer(s)				X ¹			
Clean air cleaner element				X ³			
Replace engine oil and filter				X ⁴			
Replace hydraulic oil filter element					X ⁴		
Replace water separator filter					X ⁵		
Lubricate blade shaft seals					X ⁶		
Replace fuel filter					X		
Replace primary and safety air filters					X		
Change radiator coolant						X ⁶	
Replace oil separator filter							X

- 1 - Service as required
- 2 - Initially change at 20 operating hours
- 3 - Clean more often if operating in dusty conditions
- 4 - Initially change at 50 operating hours
- 5 - Or 1 year whichever occurs first
- 6 - Or 2 years whichever occurs first

Daily Service

Check Engine Oil Level

Prior to checking the engine oil level, ensure that there is no blade installed on the saw and that the saw frame is in a level position.

1. Remove the engine oil dipstick from the left side of the engine just in front of the oil filter.



Engine Oil Dipstick

2. Check the oil level on the dipstick. The level should be between the two round marks.



Engine Oil Level Indicators

3. If the level is low, remove the engine oil fill cap located on the top of the engine under the air shield



Engine Oil Fill Cap

4. Add oil until the level is correct.
5. Replace the engine oil fill cap.

Check Fuel Level

Prior to checking the fuel level, ensure that there is no blade installed on the saw and that the saw frame is in a level position.

1. If fuel level is low, as indicated by the low fuel level icon on the display panel, remove the fuel tank fill cap located on the left top side of the upright assembly.



Fuel Tank Fill Cap

2. Fill the fuel tank with ultra-low sulfur diesel fuel only.

Hydraulic System

! WARNING

Always place a piece of cardboard or paper up against hydraulic components, or use a leak detection fluid to check for hydraulic fluid leaks. Keep all body parts away from leaks and/or areas that may eject hydraulic fluid. Pressurized hydraulic fluid can penetrate the skin, causing serious injuries. Seek medical attention immediately!



Always make sure any hydraulic components being serviced are not supporting the weight of other saw components. If a particular component is under pressure when connections points are loosened, oil may spray out forcefully.

Inspect all hydraulic hoses and fittings daily for leaks. Remember to use cardboard or a piece of paper when checking for leaks and replace damaged components immediately.

Check Hydraulic Fluid Level for Hydro Pump Assembly

Prior to checking the hydraulic fluid level, ensure that there is no blade installed on the saw and the saw frame is in a level position.

1. Check the hydro pump reservoir tank level.



Hydro Pump Reservoir Tank

2. If the level is below the "Full Cold" line then, remove the reservoir tank cap.
3. Add SAE 15W-40 oil to the reservoir tank fill line. DO NOT overfill as fluid will leak out from the reservoir cap.
4. Replace the cap and tighten to secure.

Adding Fluid to the Hydraulic Lift Pump

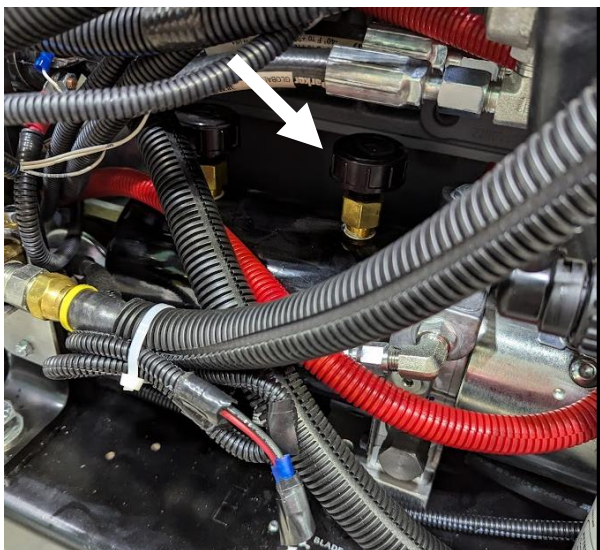

Hydraulic Lift Pump Breather Cap

Check the fluid daily and add fluid to the pump as necessary.

1. Lower the saw to level the frame.
2. Unlatch and open the left side door.
3. Remove the hydraulic pump breather cap.
4. Using a funnel, add SAE15W-40 oil or an equivalent to just below where the fill port extends into the hydraulic pump. Do not overfill, as this will cause oil leakage through the breather cap when raising the saw.
5. Replace the breather cap and retighten to secure.
6. Close the left side door and latch to secure.

Checking Radiator Coolant Level

The coolant system is a pressurized system. Care must be taken when servicing the system.

Prior to checking the radiator coolant level, ensure that there is no blade installed on the saw and the saw frame is in a level position.

1. Remove the cap from the coolant expansion tank.



Coolant Expansion Tank

2. Visually inspect the coolant level, it should be to the bottom of the fill tube.
3. If it is below the fill tube add a 50/50 mix of water and antifreeze as called out in the CC7574DD-PRO Parts List, to the expansion tank. Fill only to the bottom of the fill tube, approximately 50% of tank capacity, to ensure enough air volume is present for coolant expansion.
4. Replace the coolant expansion tank cap and tighten to secure.

Check and Clean Blade Guard Spray Tubes

1. Raise the front of the blade guard and pin it in place using the hinge detent pin (26" and larger).
2. Connect a water supply source to the water manifold on the blade guard.
3. Turn the water supply on and verify that water is spraying from all spray tube holes.
4. If any clogged holes are detected, shut off water source and dislodge any debris that is clogging the hole(s).
5. Turn water on to verify all spray tubes are clear.
6. Shut off water supply and disconnect from the water manifold.
7. Pull the detent pin on the blade guard hinge and lower the front of the guard back down.
8. Replace detent pin.

Check the Air Cleaner Restriction Indicator



Restriction Indicator

- Service the air filters when the restriction indicator turns red.
- Press the restriction indicator reset button on the top of the indicator to reset the unit after the air filters has been serviced.

Rubber Dust Ejector Boot

The rubber dust ejector boot valve ejects debris and water when operating the saw.

Occasionally inspect and clean the ejector boot.

- Press inward on both sides of the ejector boot near the valve opening to release debris and water, and clean the valve opening as necessary.



Rubber Dust Ejector Boot

Draining the Upper Gearbox Heat Sink (Cold Weather Only)

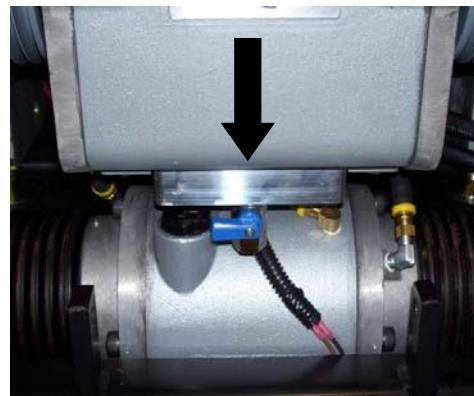

Upper Gearbox Heat Sink

Drain the heat sink daily during cold weather operations; especially in freezing weather conditions.

1. Lower the saw completely.
2. Open the water drain valve on the heat sink and drain the heat sink completely.
3. Close the water drain valve.

50 Hour Service

Drain the Fuel/Water Separator Filter

Inspect the fuel/water separator and drain as necessary. The unit is located on the left side of the saw attached to the inside of the lift frame.

1. Open the fuel door on the left side of frame upright.



Fuel/Water Separator

2. Locate the drainage cap on the underside of the fuel/water separator.
3. Loosen the cap only enough to allow water to be discharged from drainage tube. **Do not remove the cap.**
4. When no more water is discharged, re-tighten the drainage cap.
5. Close and secure fuel door.

Lubricate the Hydraulic Cylinder Pivot Pin

1. Ensure the saw is parallel to the ground.
2. Add one pump of grease into the hydraulic cylinder pivot pin grease fitting located at the back of the front axle assembly. To access it unlatch and open the right side door. The fitting is located at the frame base just in front of the cooling fan.

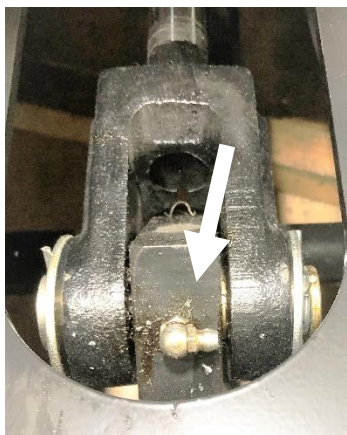

Pivot Pin Grease Fitting

Lubricate Front Axle Pivot Bearings

1. Raise the saw to the full up position.
2. Add no more than two pumps of grease to each of the two front axle bearings grease fittings located under the frame base on both the left and right side.



Front Axle Bearing Grease Fitting

Lubricate the Optional Bogie Wheel

The bogie wheel has two locations for adding grease. The first is on the wheel axle located on the side of the wheel. The second location is on the caster bracket on the back of the wheel.

1. Add one pump of grease to both grease fittings located on the bogie wheel.



Bogie Wheel Grease Fittings

100 Hour Service

Upper Gearbox

Clean the upper gearbox breather vent (inside breather cap) using compressed air to remove oil, dirt, and slurry every 100 hours.

Changing the Upper Gearbox Oil (Single Speed)

Change the upper gearbox oil every 100 hours.



Upper Gearbox Single Speed

1. Lower the saw to level the frame.
2. Place a drain pan under the gearbox drain plug (underneath gearbox, near front of box).
3. Remove the gearbox drain plug and drain the oil completely. Dispose of the used oil according to city, state, and federal regulations.
4. Replace the drain plug and retighten to secure.
5. Remove the oil fill breather cap and add Mobil 1 Synthetic Gear Lube 75W-90 oil to the upper gearbox to at least half full (view level through sight glass).
6. Replace the oil fill breather cap and retighten to secure.

Changing the Upper Gearbox Oil (3-Speed)

Change the upper gearbox oil every 100 hours.

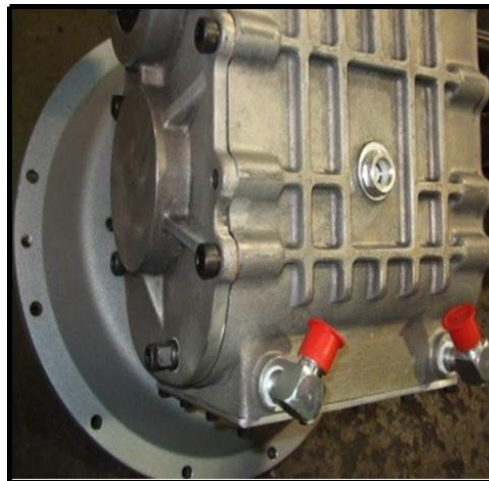

3-Speed Gearbox

1. Lower the saw to level the frame.
2. Place a drain pan under the gearbox drain plug (On the right hand side cover).
3. Remove the gearbox drain plug and drain the oil completely. Dispose of the used oil according to city, state, and federal regulations.
4. Replace the drain plug and retighten to secure.
5. Remove the oil fill breather cap and add Mobil 1 Synthetic Gear Lube 75W-90 oil to the upper gearbox to at least half full (view level through sight glass).
6. Replace the oil fill breather cap and retighten to secure.

Lower Gearbox

Changing the Lower Gearbox Oil

Change the lower gearbox fluid every 100 hours.

1. Place a drain pan under the gearbox drain plug (on back of gearbox).
2. Remove the gearbox drain plug and drain the fluid completely. Dispose of the used fluid according to city, state, and federal regulations.
3. Replace the drain plug and retighten to secure.

4. Lower saw to level frame.
5. Remove the red vinyl plug from the frame base (below gearbox) to view the fluid level from the sight glass.
6. Remove the fill cap and add Synthetic ATF fluid to the lower gearbox to at least half full (view level through sight glass).
7. Replace the fill cap and retighten to secure.
8. Replace the red vinyl plug in frame base.

Cleaning the In-Line Oil Suction Filter

Clean the in-line oil suction filter every 100 hours. Replace the filter when it cannot be properly cleaned or is damaged.



In-Line Oil Suction Filter

1. Lower the saw completely.
2. Unlatch and open the right side door.
3. Place a drain pan underneath the filter.
4. Use a wrench to hold the hex filter cap in position. Use another wrench on the barrel flats and loosen the barrel from the cap. A very small amount of oil may drain. Dispose of the used oil according to city, state, and federal regulations.
5. Remove the spring and bronze element from the barrel. Clean the inside of the barrel and the bronze filter element using an industrial cleaning solvent. Replace the filter if damaged or not cleanable.
6. Fit the bronze filter inside the spring and place the assembly back into the filter barrel.
7. Retighten the filter barrel to the hex filter cap to secure.
8. Close and latch the right side door.

250 Hour Service

Check and Clean the Water System Inlet Strainer(s)

The water system has an inlet strainer located on the right hand side of the saw between the fuel cooler and the auto water solenoid valve. Inspect this strainer daily to ensure proper water flow.

NOTE: A second inlet water strainer is included with the optional water pump.

9. Unlatch and open the right side door to locate the inlet strainer.



Water Inlet Strainer

10. Carefully unscrew the clear strainer cap from the strainer.
11. Gently remove the strainer screen from the strainer body.
12. Clean the strainer screen with low pressure water and a gentle detergent.
13. Replace the strainer screen into the strainer body.
14. Reinstall the clear strainer cap and hand tighten to secure.
15. Close and latch the right side door.

Clean the Air Cleaner Element

 **WARNING**
DO NOT operate the saw without the filter installed

1. Empty the rubber dust ejector boot by pressing inward on both sides of the ejector boot. This will release any large particles of dust or dirt.
2. Pull out the tab on the air cleaner housing end cover.



End Cover Tab

3. Turn the end cover counterclockwise to unlock and pull the cover away from the main air cleaner housing.
4. Pull the outer primary filter out of the air cleaner and inspect it for damages. Replace as necessary. To protect the engine, DO NOT pull out the inner safety filter.



Outer Primary Filter

5. Move away from the saw and clean the filter from the inside out. Use dry compressed air to clean the filter (a maximum of 30 psi or 2.1 bar) and rotate it while cleaning.
6. Inspect the inside of the air cleaner housing and the end cover for debris and wipe them down with a damp cloth as necessary. DO NOT use compressed air to blow out the inside of the air cleaner housing. DO NOT allow dust to enter the air intake tube when cleaning or replacing parts.

7. Place the filter into the air cleaner housing (over the inner safety filter) and gently push the filter into the unit until it feels secure.
8. Place the end cover tightly up against the ridge at the end of the air cleaner housing.
9. Turn the end cover clockwise to lock the cover onto the air cleaner housing, making sure the dust ejector boot is in the vertical position.
10. Push the tab in on the air cleaner housing end cover to secure.
11. Press the restriction indicator reset button on the restriction indicator after the unit has been cleaned.

Changing the Engine Oil

- Refer to Engine Operator's Manual for oil and oil filter specifications and capacities.
1. Run the engine until it reaches normal operating temperature and then shut the engine OFF.

 **WARNING**
DO NOT drain the oil with the engine running.

2. Unlatch and open the left side door.
3. Remove oil drain hose from the hose clamp by removing the M6-1.0 x 25mm screw from the frame lift.

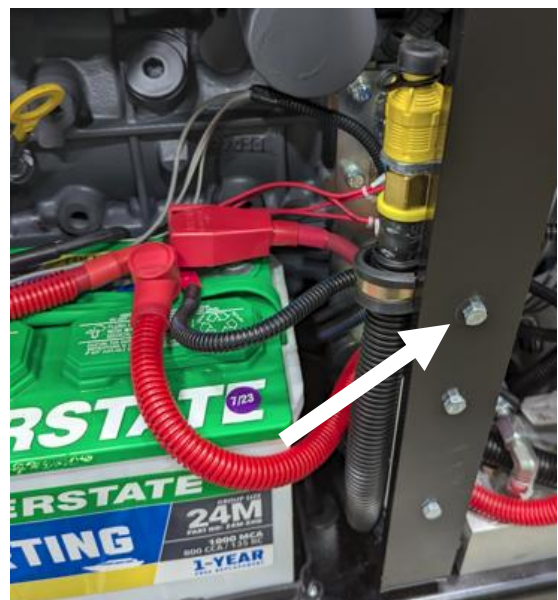

4. Level saw frame and place drain pan beneath drain hose.
5. Remove the engine oil fill cap.

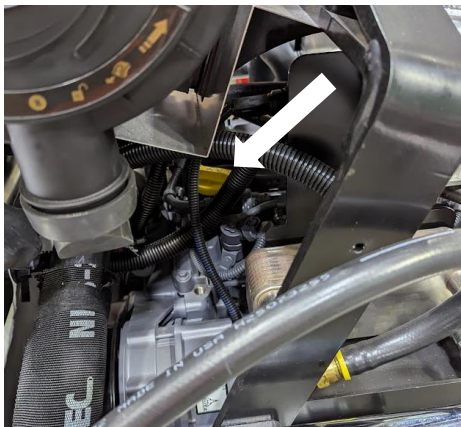

Engine Oil Fill Cap

6. Open drain valve by removing the end cap and then rotating and pulling the valve.



Oil Drain Valve

7. Drain oil completely and dispose of according to city, state, and federal regulations.
8. Remove the oil filter located on the left side of the engine using a filter wrench.

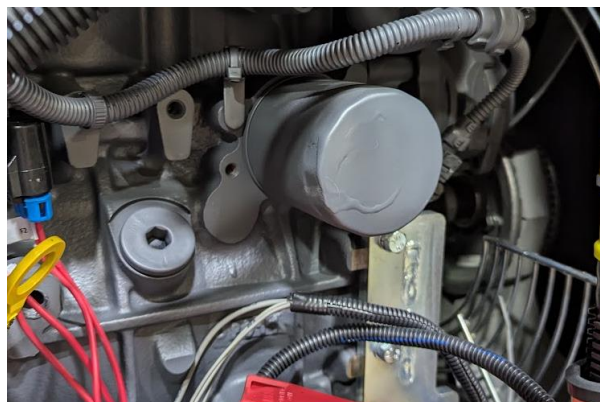

Engine Oil Filter

9. Dispose of the oil and filter in accordance with city, state, and federal regulations.
10. Shut oil drain valve and replace red plastic drain plug.
11. Install a new filter on the engine. Lubricate the rubber gasket on the filter with a film of oil prior to installing it.
12. Tighten the filter only hand tight.
13. Place a funnel with a flexible hose end into the oil fill tube on the engine.
14. Add oil in accordance with the manufacturer's specifications and capacities.
15. Replace the engine oil fill cap.
16. Reinstall the breaker panel curtain.
17. Close and latch the left side door.

500 Hour Service

Replacing the Hydraulic Oil Filter

Replace the hydraulic oil filter after the first 50 hours of operation, and then every 250 hours.

1. Lower the saw completely.
2. Place a drain pan under the filter.



Hydraulic Oil Filter

3. Remove the filter using an appropriate tool. Dispose of the used oil and filter according to city, state, and federal regulations.
4. Wipe down the sealing surface with a clean cloth and use clean oil to lightly oil the filter gasket.
5. Tighten the new filter to the filter head following the directions on the filter.
6. Start the engine and let it run for 30 seconds then shut the engine off.
7. Check the level of the hydraulic fluid in the reservoir tank and add fluid as required. **DO NOT** overfill as fluid will leak out from the reservoir cap.
8. Inspect the seal for leaks and hand tighten as necessary.

Replace the Fuel/Water Separator Filter

1. Ensure the engine is turned OFF and the saw frame is level.
2. Unlatch and open the fuel door on the left side of the frame upright.
3. Locate the drainage cap on the underside of the fuel/water separator.



Fuel/Water Separator Filter

4. Loosen the cap only enough to allow water to be discharged from drainage tube. **Do not remove the cap.**
5. When no more water is discharged, remove the electrical connector from the drainage cap and remove the cap.

6. Remove the fuel/water separator filter using a filter wrench.
7. Dispose of the filter according to city, state, and federal regulations.
8. Lubricate the rubber gasket on the filter with a film of fuel and hand tighten the filter onto the filter mount and then turn an addition 3/4 turns.
9. Reinstall the filter drainage cap and hand tighten securely.
10. Reinstall the electrical connector to the drainage cap.
11. Start the engine and check for leaks. If no leaks are present, turn the engine OFF.
12. Close and latch the left side door.

Replace the Fuel Filter

1. Ensure the engine is turned OFF and the saw frame is level.
2. Unlatch and open the left side door.
3. Place a container under the fuel filter.



Fuel Filter

4. Remove the fuel filter using a filter wrench.
5. Dispose of the fuel and filter in accordance with city, state, and federal regulations.
6. Install a new filter on the engine. Lubricate the rubber gasket on the filter with a film of fuel prior to installing it.
7. Tighten the filter to 15-18 lb-ft. (20-24 Nm).
8. Start the engine and check for fuel leaks. If no leaks are present, turn the engine OFF.
9. Close and latch the left side door.

Replacing the Outer Primary and Inner Safety Filters

1. Pull out the tab on the air cleaner housing end cover.



End Cover Tab

2. Turn the end cover counterclockwise to unlock and pull the cover away from the main air cleaner housing.
3. Remove the outer primary and inner safety filters from the air cleaner housing.



Outer Primary Filter



Inner Safety Filter

4. Inspect the inside of the air cleaner housing and the end cover for debris, and wipe necessary. DO NOT use compressed air to blow out the inside of the air cleaner housing. DO NOT allow dust to enter the air intake tube when cleaning or replacing parts.
5. Place the new inner safety filter into the air cleaner housing until it is fully seated.
6. Place the new outer safety filter into the air filter housing over the inner safety filter and gently push the filter into the unit until it feels secure.
7. Place the end cover tightly up against the ridge at the end of the air cleaner housing.
8. Turn the end cover clockwise to lock the cover onto the air cleaner housing, making sure the dust ejector boot is in the vertical position.
9. Push the tab in on the air cleaner housing end cover to secure.
10. Press the restriction indicator reset button on the restriction indicator after the unit has been cleaned.

1000 Hour Service

Changing the Radiator Fluid and Hoses

Change the radiator fluid every 500 hours of operation, or every two years (whichever comes first). DO NOT drain the radiator fluid when hot.

1. Place a drain pan under the radiator drain valve located on the bottom left side of the radiator.
2. Slowly remove the coolant expansion tank cap.

Note: Remove the expansion tank cap only when it feels cool to the touch, and always open it slowly to relieve any built-up pressure.

3. Loosen the drain valve wing nut and drain the fluid completely. Dispose of the used fluid according to city, state, and federal regulations.
4. Tighten the drain valve wing nut to secure.
5. Add a 50/50 mix of water and antifreeze as called out in the CC7574DD-PRO Parts List, to the expansion tank. Fill only to the bottom of the fill tube, approximately 50% of tank capacity, to ensure enough air volume is present for coolant expansion.
6. Replace the coolant expansion tank cap and retighten to secure.

Lubricate the Blade Shaft Seals

Every 500 hours or at least once every two years, lubricate the two front blade shaft seals. The grease fittings are located behind the left and right hand inner blade flanges.

1. Add no more than one pump of bearing grease into each of the two blade shaft bearing grease fittings.

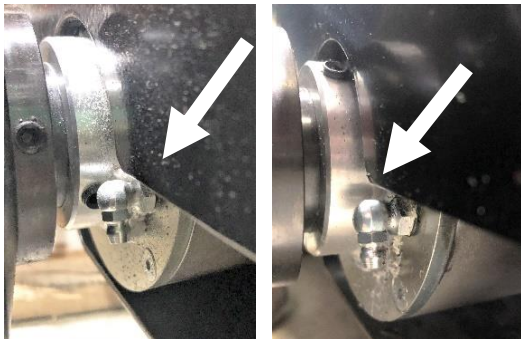

Blade Shaft Seals Grease Fittings

1500 Service Hours

Replace the Oil Separator Element

Ensure the engine is turned OFF prior to changing the oil separator element.

1. Locate the oil separator on the upper left side of the engine.



Oil Separator Cap

2. Unscrew the cap from the lower section of the oil separator body.
3. Remove the separator element and gasket.
4. Wipe oil and grease from the gasket area.
5. Fit a new gasket and separator element into position.
6. Reinstall the cap.

Regular Maintenance

Speed Control Lever

Adjusting the Lever Tension

Adjust the tension felt in the speed control lever, when moving the lever forward and backward, to the desired setting as necessary.

1. Unlatch and lower the rear cover screen.

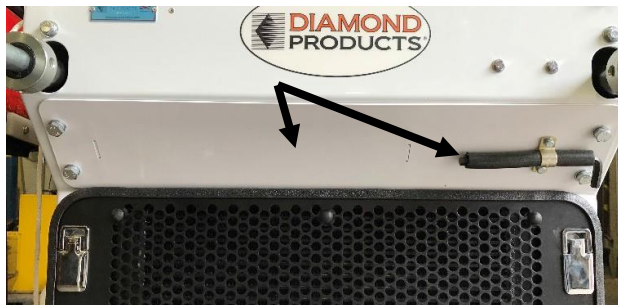

Access Panel and Allen Wrench

2. Remove the grease cap from the pivot housing.
3. Loosen the jam nut on the opposite side of the speed control frame using provided 15/16" wrench.

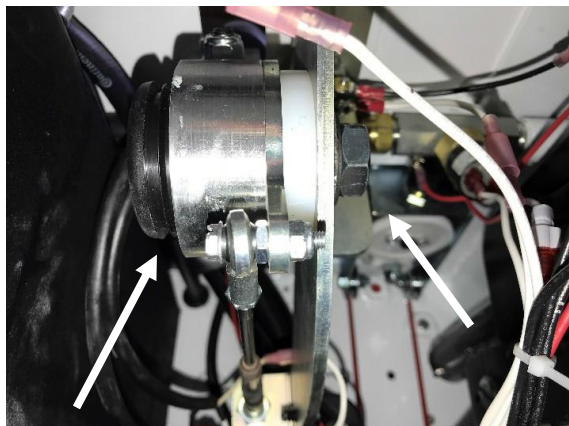

Grease Cap and Jam Nut

4. Use the Allen wrench, located on the access panel, to adjust the shoulder screw.
5. Retighten the jam nut.
6. Move the speed control lever forward and backward to test the lever tension. Readjust the shoulder screw and jam nut if desired.
7. Secure the grease cap to the pivot housing.
8. Close the rear cover screen and latch to secure.

Adjusting the Spring Plungers

Adjust the spring plungers if the speed control lever feels too tight or too loose when moving the lever forward and backward, or when the lever is hard to place into or out of the *Stop* position.

1. If the lever is tight it could be caused by slurry in the speed control components. Use a spray lubricant on the spring plungers to free the controller. If this doesn't correct the problem continue on to step 2.
2. Loosen both hex nuts from the speed control tube.
3. Screw the spring plungers slightly out to let the speed control lever move easily into and out of the *Stop* position. Screw the spring plungers slightly in to let the speed control lever move forward and backward firmly in the forward/reverse slot.
4. Retighten both hex nuts to secure.

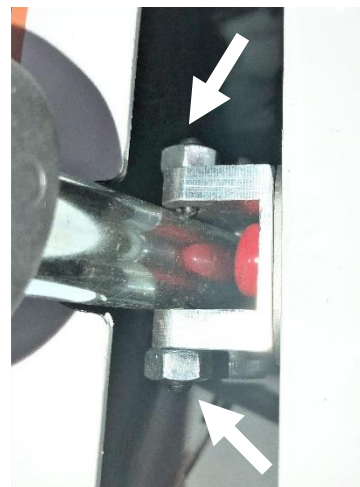

Spring Plunger Hex Nuts

Inner Blade Flange

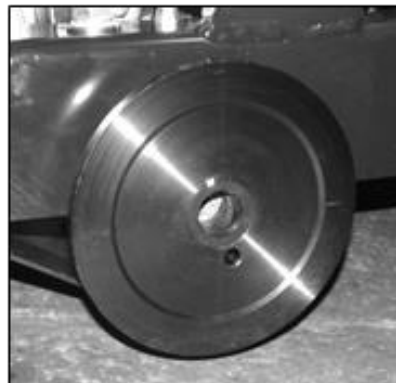

Inner Flange

Installing the Inner Blade Flange

1. Inspect the inner flange for damages. Clean or replace damaged components as necessary.
2. Align the flange with the blade shaft key and place the flange onto the blade shaft.
3. Apply Loctite 262 (red) or an equivalent to the setscrew threads.
4. Tighten the setscrew(s) into the back of the inner flange to secure.

Removing the Inner Blade Flange

1. Remove the setscrew(s) from the back of the inner flange using an Allen wrench.
2. Carefully remove the flange from the blade shaft.

Drive Alignment

Adjusting the Drive Alignment

Adjust the rear axle when the saw's drive alignment is off (saw will not cut in a straight line).

Note: The rear axle does not have to be adjusted for straightness; it can also be adjusted based on the specifications of the cutting job.

1. Turn the tap bolt clockwise using the provided wrench to adjust the drive alignment toward the right, or counterclockwise to adjust the drive alignment toward the left.



Adjustment Bolt

Wheels



- Raise the saw to a proper height for access when working underneath the saw. Use chocks to block the wheels, and fit blocks or jacks under the frame edges at the front and back of the frame.



Front Wheels

Replacing the Front Wheels

Replace the front wheels when they are damaged and/or affecting saw performance.

1. Move the saw to level ground. Use a jack to lift the front wheels off the ground.
2. Remove all four screws from the wheel cover.
3. Pry the wheel cover gasket and wheel cover off the wheel using a screwdriver or pry bar.
4. Remove the screw securing the wheel, and then remove the wheel from the front axle.
5. Place a new wheel onto the front axle.
6. Fit the lock washer and then the flat washer onto the wheel screw and retighten the screw through the center of the wheel to secure.
7. Replace the wheel cover gasket and wheel cover, and retighten all four wheel cover screws to secure.
8. Replace the second front wheel as directed above.
9. Slowly lower the jack and remove the jack stand when the wheels are firmly touching the ground.

Replacing the Rear Wheels

Replace the rear wheels when they are damaged and/or affecting saw performance.



Rear Wheel

1. Move the saw to level ground. Use a jack to lift the rear wheels off the ground.
2. Pry the hubcap off the wheel using a screwdriver or pry bar.
3. Remove all four lug nuts from the wheel.
4. Remove the wheel and place a new wheel onto the wheel hub.
5. Replace the lug nuts and tighten to secure.
6. Replace the hubcap and secure in place using a rubber mallet.
7. Replace the second rear wheel as directed. Slowly lower the jack and remove the jack stand when the wheels are firmly touching the ground.

Maximum Cutting Depth



WARNING

- Raise the saw to a proper height for access when working underneath the saw. Use chocks to block the wheels, and fit blocks or jacks under the frame edges at the front and back of the frame.

Always adjust the maximum cutting depth when changing the blade size, sheave size, flange size, and belt size to avoid damaging saw components. Refer to the CC7574DD-PRO Parts List for additional information.

1. Raise the saw to gain access to the maximum cutting depth bolts underneath the frame base.

2. Loosen the nut on both bolts.
3. Turn the bolts counterclockwise to decrease the maximum cutting depth, or turn the bolts clockwise to increase the maximum cutting depth.

Note: Both bolts must be the same length when finished.



Maximum Depth Bolts

4. Bottom out the nut on each bolt with the frame base to secure the bolts.
5. Remove all tools from the area and lower the saw completely. The blade flanges must be at least 1/4" from the ground to prevent component damage.

Note: Make sure both skid plates on the front of the saw are in the correct set of holes to lower the saw completely (refer to CC7574DD-PRO Parts List).

6. Readjust the depth bolts as necessary.

Handlebar Cylinder Rod

The handlebar cylinder rod must be serviced by Diamond Products if the handlebars can be moved up or down in excess amounts when locked in place (movement may feel sluggish). Send the entire assembly to Diamond Products to be recharged or pressurized.

Removing the Cylinder Rod

1. Disconnect the two wires from the solenoid block valve.
2. Remove the hairpin cotter and clevis pin from the cylinder rod end.



Clevis Pin

3. Holding the cylinder, remove the hairpin cotter and clevis pin from the isolator mount tube.
4. Remove the entire assembly from the saw.

Connecting the Cylinder Rod

1. Fit the cylinder into the cylinder rod end mount and isolator mount tube.
2. Fit the clevis pin through the cylinder rod end mount and cylinder rod end. Secure in place with the hairpin cotter.
3. Fit the second clevis pin through the isolator mount tube and cylinder u-block. Secure in place with the hairpin cotter.

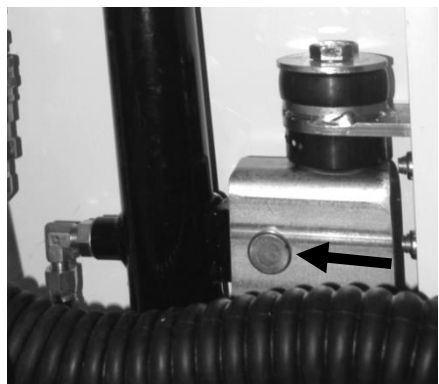

Clevis Pin

4. Connect the two wires to the solenoid block valve according to the wiring diagrams in the CC7574DD-PRO Parts List.

Battery

 **WARNING**

- Ignitable explosive gases are emitted from the battery. DO NOT expose the battery to sparks or open flames, and keep the area around the battery well ventilated.
- Disconnect the battery prior to servicing the saw unless stated otherwise.
- Always keep the battery cable clamps away from the battery terminals when the battery is disconnected to avoid accidental connections while servicing.
- Always be sure to connect the battery cables to the proper terminal when reconnecting.

 **CAUTION**

- Use a proper battery tester when testing the battery strength.
- Use protective eyewear or a face shield and avoid contact with the skin when handling/servicing the battery.

The saw contains a charged battery with one positive cable lead and one negative cable lead.



Battery

Battery Type

12 Volt, Group 24

Servicing the Battery

1. Unlatch and open the left side door.
2. Unbuckle the battery hold-down strap.
3. Disconnect the negative cable lead from the negative terminal.

Note: Always disconnect the negative cable first.

4. Disconnect the positive cable lead from the positive terminal.
5. Carefully remove the battery from the battery box.
6. When replacing the battery, carefully place a new battery into the battery box. Bring the old battery to a recycling facility; many battery retailers also accept old batteries.
7. When cleaning the battery, inspect the terminals, clamps, and cables for damages and corrosion. Clean the terminals and clamps using a wire brush, or use another approved technique for cleaning. Use acid-free, acid-resistant grease to grease the battery clamps and terminals. Carefully place the battery back into the battery box.
8. Reconnect the positive cable lead to the positive battery terminal. Note: Always reconnect the positive cable first.
9. Reconnect the negative cable lead to the negative battery terminal.
10. Re-attach the hold-down strap to the buckle and tighten securely.
11. Close and latch the left side door.

Electrical System



WARNING

- Disconnect the battery prior to servicing the saw unless stated otherwise.
- Always use the correct size fuses (amps) to prevent fires.

Inspect all fuses if switches or controls are not working properly and replace as necessary. If fuses are failing frequently, determine the cause and repair immediately. Refer to the CC7574DD-PRO Parts List for electrical diagrams.

Belt Sheaves

The upper and lower belt sheaves may need to be changed when changing the blade size. Refer to the CC7574DD-PRO Parts List for additional information.

Removing the Belt Sheaves

1. Unlatch and open the front hood.
2. Loosen the two engine cradle screws using the 1-1/16" & 1-1/8" open end wrench located on the inside of the left side door.



Engine Mount Wrench

3. Loosen the nut away from the engine foot on both blade drive belt tension bolts using the 1-1/16" & 1-1/8" open end wrench.
4. Turn both blade drive belt tension bolts (large threaded bolt on engine foot) counterclockwise to loosen the belts.
5. Remove both sets of belts from the four sheaves.
6. Remove both setscrews from one of the sheaves.

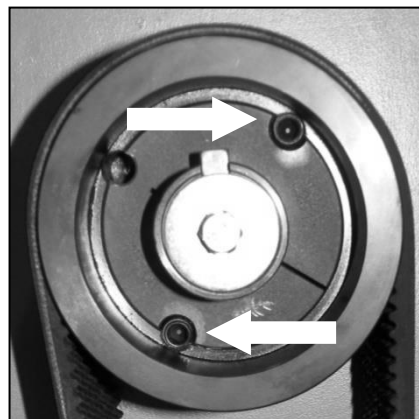

Sheave Setscrews

7. Place one of the removed setscrews into the third setscrew hole (in line with slot) on the bushing. Using a 1/2" impact wrench, tighten the setscrew into the hole to separate the sheave from the bushing. If the sheave and bushing will not separate, wedge a flat-head screwdriver into the slot on the bushing and tap the other end of the screwdriver with a rubber mallet to separate the sheave and bushing.
8. Remove the sheave from the bushing.
9. Repeat steps 5–7 to remove the three remaining sheaves.
10. Remove the setscrew used to separate the sheave and bushing from all four bushings.

Installing Belt Sheaves

1. Fit the appropriate size sheave onto each bushing.
2. On one side of the saw, place a straightedge against the edge of the upper or lower sheave. Adjust either sheave to align the outside edge of both sheaves.
3. Place two setscrews into the setscrew holes (in line with each other) on both sheaves and retighten the setscrews to secure.

Note: Make sure both sheaves are properly aligned prior to securing.

4. Repeat steps 2–3 for the second set of sheaves.
5. Reinstall both sets of belts on the sheaves.
6. Turn both blade drive belt tension bolts (large threaded bolt on engine foot) clockwise equally to tighten the belts. Test the belt tension and readjust the bolts as necessary. DO NOT exceed the manufacturer's tension settings.
7. Tighten the nut on both blade drive belt tension bolts down to the engine foot.
8. Retighten the two engine cradle screws.
9. Close and latch the front hood assembly.

Blade Drive Belts

! WARNING

- Turn off the engine prior to servicing the belts.
- Use extreme caution when working with belts and rotating machine parts to avoid entanglement.

! CAUTION

- Let the belts cool down prior to servicing them.

Inspect all belts daily for fraying, stress cracks, and/or breakage and replace immediately when damaged. Always re-tension new belts after the first four hours of use. DO NOT exceed the manufacturer's recommended belt tension settings when tensioning belts.

Note: Over-tensioning belts may reduce the life of the gearbox bearings. Under-tensioning belts may cause slippage, shorter belt life, and/or poor saw performance. Squealing belts indicate looseness.

Tensioning/Replacing the Blade Drive Belts

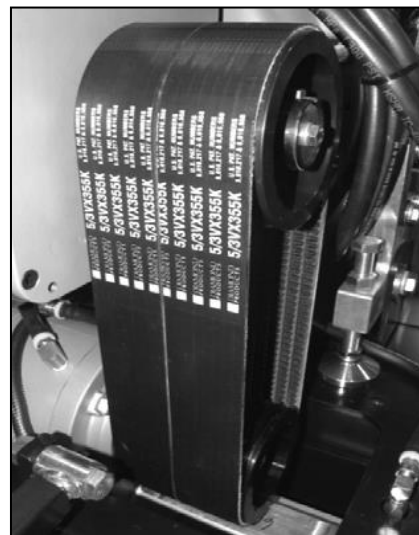

Blade Drive Belts

1. Unlatch and open the front hood.
2. Test the belt tension.
3. Loosen the two engine cradle screws using the 1-1/16" & 1-1/8" open end wrench located on the inside of the left side panel door.
4. If tensioning the belts, proceed with steps 9-12. If replacing the belts, continue with steps 5-12.
5. Loosen the nut away from the engine foot on both blade drive belt tension bolts using the 1-1/16" & 1-1/8" open end wrench
6. Turn both blade drive belt tension bolts (large threaded bolt on engine foot) counterclockwise to loosen the belts.

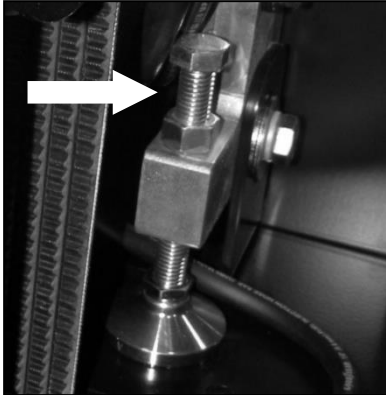

Belt Tension Bolt

7. Remove both sets of belts from the four sheaves.
8. Loop and align the first matched set of belts around the lower gearbox sheave and then around the upper gearbox sheave, and repeat with the second matched set of belts. Repeat the procedure for the second set of sheaves.

Note: Make sure the belts are fitted against each other, and are aligned on the sheaves.

9. Turn both blade drive tension bolts (large threaded bolt on engine foot) clockwise equally to tighten the belts. Test the belt tension and readjust the bolts as necessary. **DO NOT** exceed the manufacturer's tension settings.
10. Tighten the nut on both blade drive belt tension bolts down to the engine foot.
11. Retighten the two engine cradle screws.
12. Close and latch the front hood assembly.

Engine



WARNING

- Let the engine cool down prior to servicing the saw.
- **DO NOT** service the saw with the engine running unless otherwise stated.

Refer to the engine manual and manufacturer for a full engine maintenance schedule and additional engine maintenance information.

Cleaning the Engine

Clean and wipe down the engine's exterior, fans, and guards daily to prevent high operating temperatures.

Storing

Complete the tasks listed below prior to storing the saw for longer time frames:

- Drain the water lines/hoses.
- Turn off all switches and controls.
- Lower the saw completely to remove strain on the lifting mechanism.
- Clean and wipe down the saw to remove dust, debris, and slurry from saw components (especially fans).
- Remove the battery and store in a proper location, out of reach from children
- Refer to the engine manual for all engine and fuel recommendations prior to storing.
- Store the saw in a dry area, protected from outdoor elements and out of reach from children.
- Refer to the engine manual for all engine and fuel recommendations prior to storing.
- Store the saw in a dry area, protected from outdoor elements and out of reach from children.

Disposal

Dispose of the saw when it's no longer repairable, and/or contains safety hazards not worth repairing or maintaining. Complete the tasks listed below when discontinuing usage:

- Drain all fluids and dispose of according to city, state, and federal regulations.
- Remove the battery and bring to a recycling facility; many battery retailers also accept old batteries.
- Transport the saw to a salvage yard or recycling facility.

References

Appendix A

Troubleshooting

Troubleshooting the CC7574DD-PRO		
Symptom	Problem	Solution
1. Engine will not start.	Out of Fuel?	Fill fuel tank.
	Fuel lines clogged?	Unclog or replace fuel lines.
	Air in fuel lines?	Bleed fuel lines.
	Worn out battery?	Charge or replace battery.
	Faulty battery connection?	Inspect, clean, and tighten battery
	Engine malfunction?	Refer to engine manual.
	Bad fuse?	Check and replace bad fuses.
2. Engine will not start due to a shutdown condition indicated on display panel. <i>NOTE: All problems must be cleared before saw will restart.</i>	E-Stop is active.	Pull up emergency stop button.
	Fuel door panel is open.	Shut and latch the fuel door.
		Check for proper operation of the door interlock switch.
3. Low engine coolant level warning indicated on display panel. <i>NOTE: Saw will continue to run at reduced power until engine is turned off. If the problem is not cleared a shutdown warning will be displayed the next time the keyed is turned to the on position.</i>	Coolant level is extremely low.	Fill the coolant system in accordance with the "Adding Radiator Fluid" procedure outlined in the Maintenance section of this manual
4. Saw will not raise.	Defective solenoid start switch?	Replace solenoid on hydraulic pump unit.
	Worn out battery?	Charge or replace battery.
	Defective raise button?	Replace raise button.
	Low hydraulic fluid?	Check hydraulic fluid level and fill as necessary.
5. Saw will not lower.	Debris in lowering valve	Inspect and clean stem.
	Worn out battery?	Charge or replace battery
	Defective valve coil?	Check for magnetism of valve stem when activated.
	Defective lowering button?	Replace lowering button.

Troubleshooting the CC7574DD-PRO		
Symptom	Problem	Solution
6. Saw will not lower completely.	Depth stop set?	Reset depth stop.
	Skid plates in wrong set of holes?	Adjust skid plates to correct set of mounting
	Maximum cutting depth set incorrectly?	Adjust maximum cutting depth bolt.
7. Saw lowers too slow or too fast.	Improper lowering speed setting?	Adjust blade lowering speed valve.
8. Blade does not cut straight.	Drive alignment off?	Adjust rear axle adjustment bolt.
	Excessive force used when sawing?	Reduce forward speed. DO NOT twist blade from side to
	Wrong blade?	Contact dealer/manufacturer of
9. Short belt life.	Loose belts causing	Check and adjust belt tension.
	Sheaves misaligned?	Use straightedge to check blade shaft sheave alignment. Adjust
	Worn sheave grooves?	Check for groove wear and replace sheaves when
	Mismatched belts?	Replace with matched set of belts. DO NOT use old and

Appendix B

CC7574DD-PRO RPM Chart

CC7574 SINGLE SPEED RPM CHART

BLADE SIZE	BLADE RPM	LOWER SHEAVES	UPPER SHEAVES	ENGINE RPM	BELT SIZE	FLANGE SIZE	MAX CUT DEPTH
20"	2,300	4.50"	6.50"	2,600	3VX385	5"	7-1/4"
26"	1,875	4.75"	5.60"	2,600	3VX375	5"	10-1/4"
30"	1,675	4.75"	5.00"	2,600	3VX366	5"	12-1/4"
36"	1,375	4.75"	6.50"	2,600	3VX385	6"	14-3/4"
42"	1,125	4.75"	5.30"	2,600	3VX375	7"	17-1/4"
48"	1,000	4.75"	4.75"	2,600	3VX366	8"	19-3/4"

CC7574DD-PRO-3 RPM Charts

CC7574 3 SPEED RPM CHART - 30"/26"/20"

BLADE SIZE	BLADE RPM	GEAR POSITION	MAX CUT DEPTH	LOWER SHEAVES	UPPER SHEAVES	ENGINE RPM	BELT SIZE	FLANGE SIZE
20"	2,650	H (high)	7-1/4"	4.75"	4.75"	2,600	3VX450	5"
26"	1,950	M (mid)	10-1/4"	4.75"	4.75"	2,600	3VX450	5"
30"	1,500	L (low)	12-1/4"	4.75"	4.75"	2,600	3VX450	5"

CC7574DD-PRO OPERATOR'S MANUAL

CC7574 3 SPEED RPM CHART - 36"/30"/20"

BLADE SIZE	BLADE RPM	GEAR POSITION	MAX CUT DEPTH	LOWER SHEAVES	UPPER SHEAVES	ENGINE RPM	BELT SIZE	FLANGE SIZE
20"	2,400	H (high)	6-3/4"	4.50"	6.50"	2,600	3VX475	6"
30"	1,775	M (mid)	11-3/4"	4.50"	6.50"	2,600	3VX475	6"
36"	1,375	L (low)	14-3/4"	4.50"	6.50"	2,600	3VX475	6"









CC7574 3 SPEED RPM CHART - 42"/36"/26"

BLADE SIZE	BLADE RPM	GEAR POSITION	MAX CUT DEPTH	LOWER SHEAVES	UPPER SHEAVES	ENGINE RPM	BELT SIZE	FLANGE SIZE
26"	1,975	H (high)	9-1/4"	4.75"	5.60"	2,600	3VX475	7"
36"	1,450	M (mid)	14-1/4"	4.75"	5.60"	2,600	3VX475	7"
42"	1,125	L (low)	17-1/4"	4.75"	5.60"	2,600	3VX475	7"

CC7574DD-PRO OPERATOR'S MANUAL

CC7574 3 SPEED RPM CHART - 48"/42"/30"

BLADE SIZE	BLADE RPM	GEAR POSITION	MAX CUT DEPTH	LOWER SHEAVES	UPPER SHEAVES	ENGINE RPM	BELT SIZE	FLANGE SIZE
30"	1,675	H (high)	10-3/4"	4.75"	4.75"	2,600	3VX450	8"
42"	1,225	M (mid)	16-3/4"	4.75"	4.75"	2,600	3VX450	8"
48"	950	L (low)	19-3/4"	4.75"	4.75"	2,600	3VX450	8"

CC7574DD-PRO Blade Size Conversion Chart

WARNING: When changing blade size, use chart shown below for selecting items that must be changed.

Model CC7574	20"	26"	30"	36"	42"	48"
Blade Shaft Assembly	6018186 (Option A)	6018186 (Option A)	6018186 (Option A)	6018141 (Option B)	6018141 (Option B)	6018141 (Option B)
Blade Guard Assembly	6010952	6010954	6010956	6010958	6010960	6010962
Upper Sheaves (2) (Sheave Size)	6017438 (6.5")	6013157 (5.6")	6017436 (5")	6017438 (6.5")	6017437 (5.3")	6017435 (4.75")
Lower Sheaves (2) (Sheave Size)	6017434 (4.5")	6017435 (4.75")	6017435 (4.75")	6017435 (4.75")	6017435 (4.75")	6017435 (4.75")
Drive Belts (20) (Belt Size)	2503876 (3VX385)	2500037 (3VX375)	2503875 (3VX366)	2503876 (3VX385)	2500037 (3VX375)	2503875 (3VX366)
Inner Flanges (2) (Flange Size)	6010255 (5")	6010255 (5")	6010255 (5")	6010038 (6")	6017230 (7")	6013017 (8")
Outer Flanges (2) (Flange Size)	6047907 (5")	6047907 (5")	6047907 (5")	6010039 (6")	6017231 (7")	6013018 (8")
Skid Plate Mounting Holes	Bottom Set	Bottom Set	Bottom Set	Middle Set	Middle Set	Top Set
Tachometer Pulses	27	27	27	34	34	34

CC7574DD-PRO-3 Blade Size Conversion Chart

WARNING: When changing blade size, use chart shown below for selecting items that must be changed.

Model CC7574-3 Speed	30/26/20	36/30/20	42/36/26	48/42/30
Blade Shaft Assembly	6018230 (Option A)	6018232 (Option B)		
Blade Guard Assembly	6010956	6010958	6010960	6010962
Upper Sheaves (2) (Sheave Size)	6017435 (4.75")	6017438 (6.5")	6013157 (5.6")	6017435 (4.75")
Lower Sheaves (2) (Sheave Size)	6017435 (4.75")	6017434 (4.5")	6017435 (4.75")	
Drive Belts (20) (Belt Size)	2500794 (3VX450)	2500298 (3VX475)		2500794 (3VX450)
Inner Flanges (2) (Flange Size)	6010255 (5")	6010038 (6")	6017230 (7")	6013017 (8")
Outer Flanges (2) (Flange Size)	6047907 (5")	6010039 (6")	6017231 (7")	6013018 (8")
RPM Chart Decal	1802512A	1802512B	1802512C	1802512D
Skid Plate Mounting Holes	Bottom Set	Middle Set		Top Set
Tachometer Pulses	27	34		

Appendix C

Additional Resources

1. Deutz (www.deutzusa.com)
 - Operator's Manual Deutz Engine, TD-2.9-L4
2. Diamond Products (www.diamondproducts.com)
 - CC7574DD-PRO Concrete Saw Parts List; Ohio, 2024
 - A Guide for Professional Concrete Cutters
 - Training Manual – Introduction to Diamond Blades, Bits, and Equipment
 - Diamond Products' Equipment Catalog
 - Diamond Products' Website (www.diamondproducts.com)
3. Concrete Sawing and Drilling Association (www.csda.org)
 - The CSDA has many helpful concrete cutting publications available to members and non-members.
4. Association of Equipment Manufacturers (www.aem.org)
 - The AEM has a variety of safety and technical manuals available for various types of equipment, along with a list of industry-standardized safety symbols.
5. Occupational Safety & Health Administration (OSHA) (www.osha.gov/)
 - OSHA provides information on work-related safety and health practices.
6. The National Institute for Occupational Safety and Health (NIOSH) (www.cdc.gov/NIOSH/)
 - NIOSH provides information on work-related safety and health practices.

Appendix D

Model and Serial Numbers

Record the saw's serial number below for future reference and customer service purposes.

Serial Number	
---------------	--

Record the engine's model and serial numbers below for future reference and customer service purposes.

Model Number	
Serial Number	

EQUIPMENT AND PARTS WARRANTY

Diamond Products warrants all equipment manufactured by it against defects in workmanship or materials for a period of one (1) year from the date of shipment to Customer.

The responsibility of Diamond Products under this Warranty is limited to replacement or repair of defective parts at Diamond Products' Elyria, Ohio factory, or at a point designated by it, of such parts as shall appear to us upon inspection at such parts, to have been defective in material or workmanship, with expense for transportation and labor borne by Customer.

In no event shall Diamond Products be liable for consequential or incidental damages arising out of the failure of any Product to operate properly.

Integral units such as engines, electric motors, batteries, transmissions, etc., are excluded from this Warranty and are subject to the prime manufacturer's warranty.

THIS WARRANTY IS IN LIEU OF ALL OTHER WARRANTIES, EXPRESSED OR IMPLIED, AND ALL SUCH OTHER WARRANTIES ARE HEREBY DISCLAIMED.



333 Prospect Street, Elyria, Ohio 44035
(440) 323-4616 • (800) 321-5336 • Fax (800) 634-4035
www.diamondproducts.com