



**CORE VAC
PARTS LIST**

**CV258C
Electric Vac**

JULY, 2024

Table of Contents

<u>Description</u>	<u>Page No.</u>
1. Head	4
2. Filter	5
3. Shake Bar	6-7
4. Main Drum.....	8
5. Dust Drums.....	9
6. Additional Accessories.....	10
5. Notes.....	12
6. Warranty.....	14

HEAD PARTS

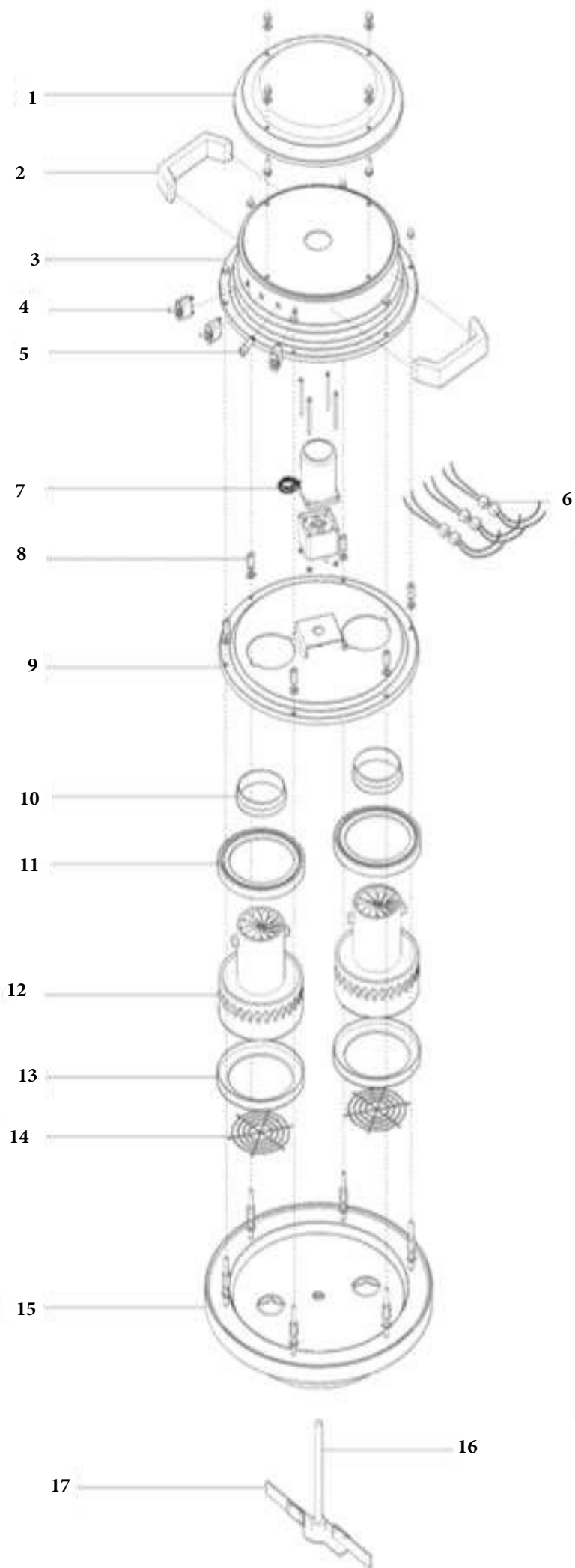

FILTER PARTS

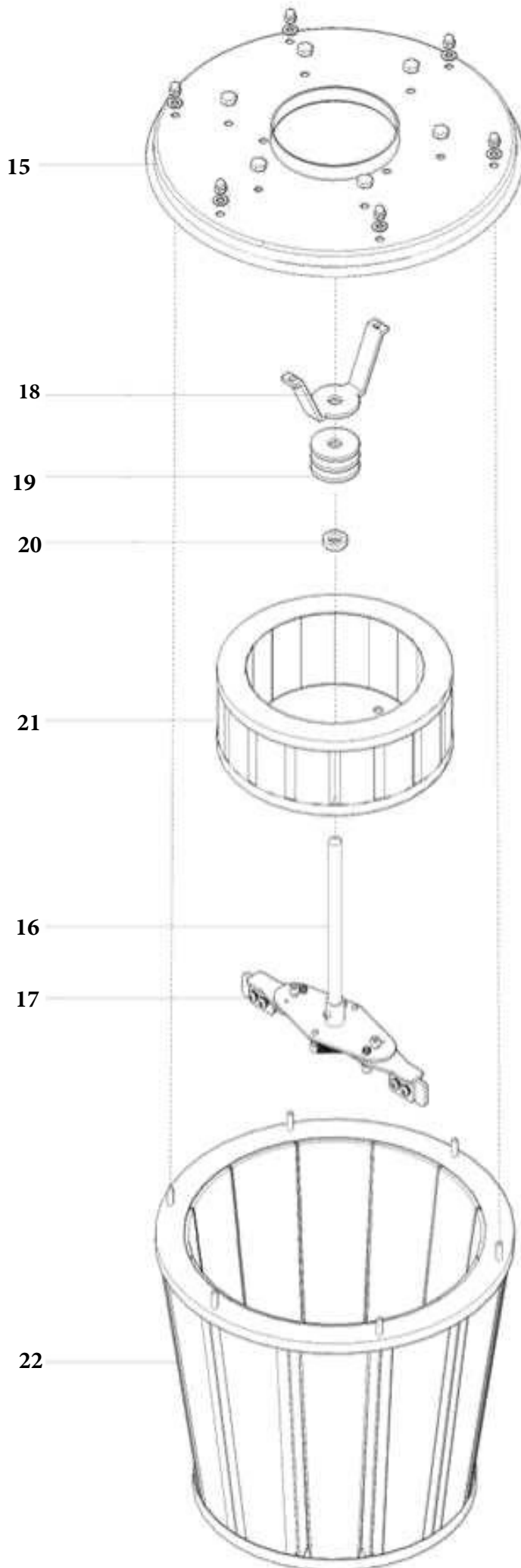

SHAKE BAR PARTS

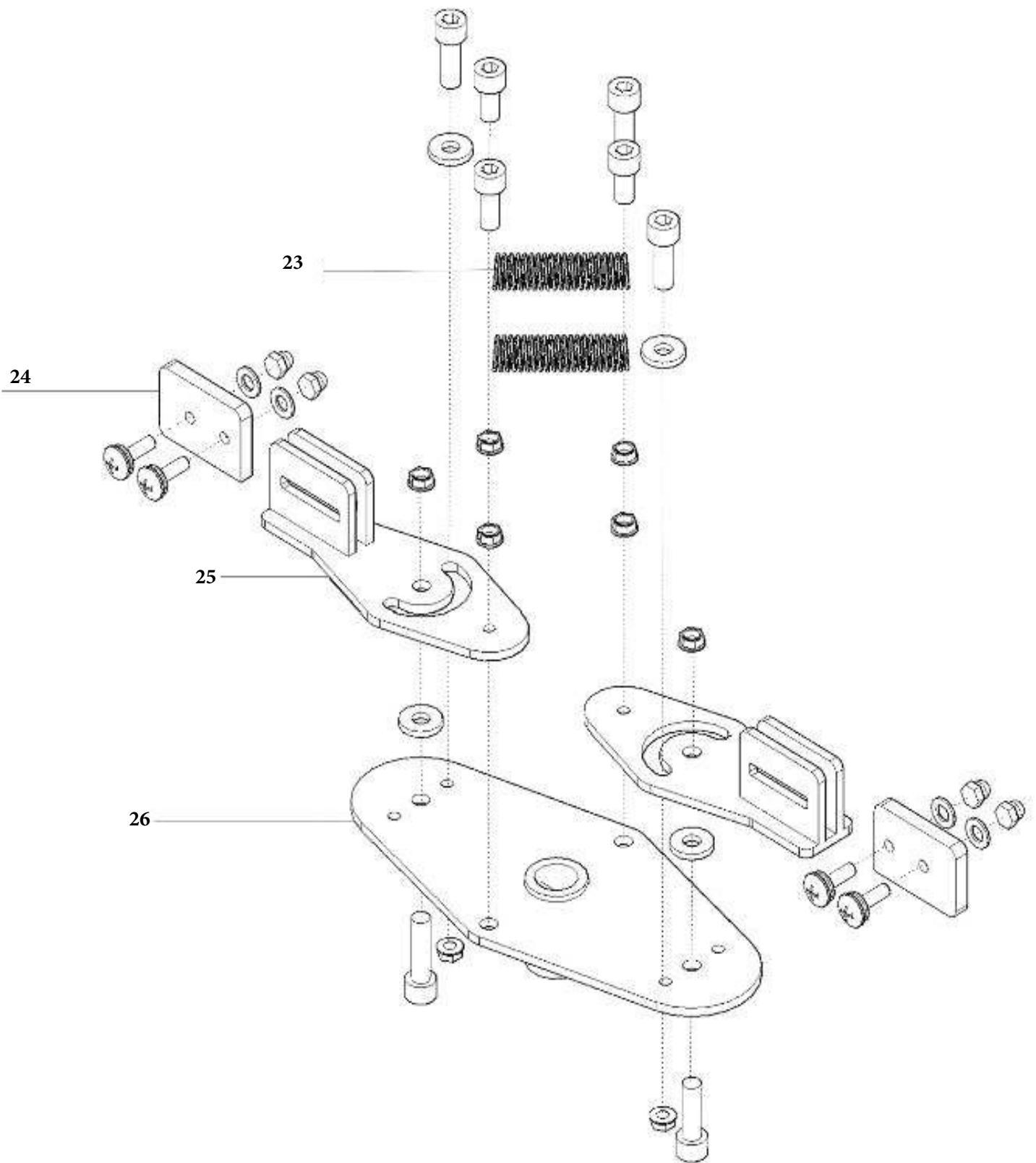

MAIN DRUM PARTS

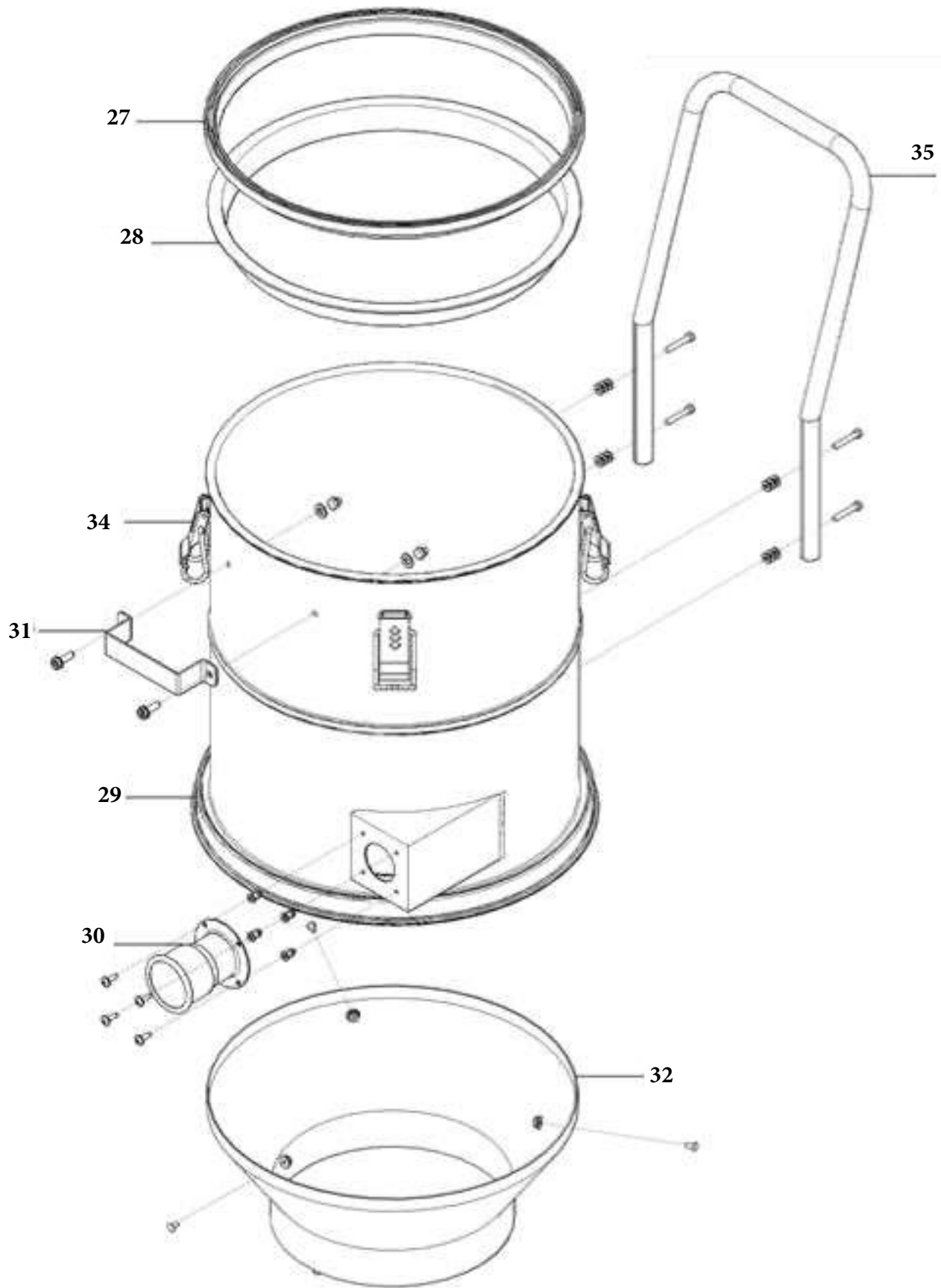

DUST DRUM PARTS

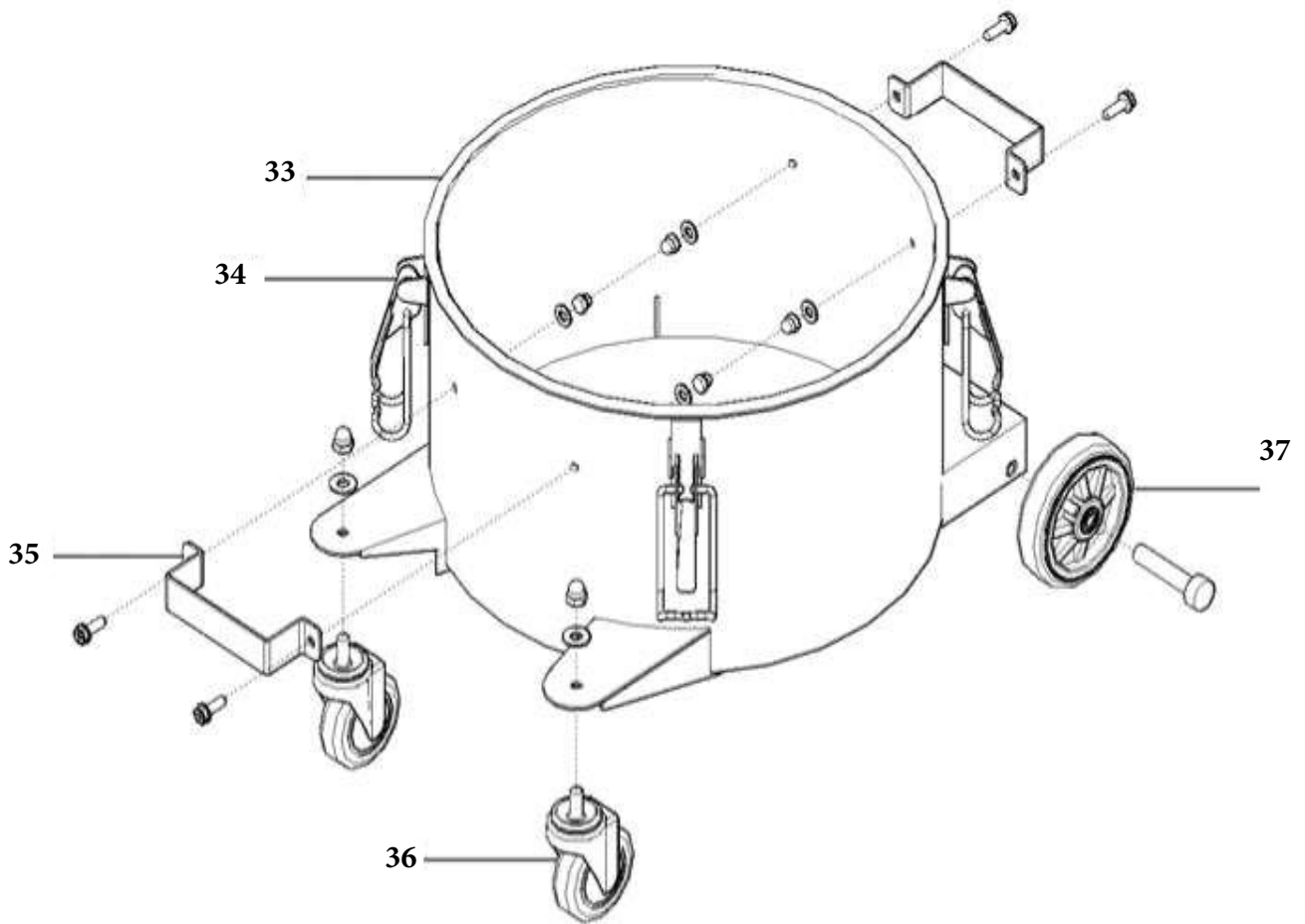

	DP #	DESCRIPTION
1	2508649	TOP HEAD COVE
2	2508586	HEAD HANDLE
3	2508650	MID COVER
4	2508585	ON/OFF SWITCH
5	2508610	LED LAMP
6	2508596	MOTOR & ON/OFF SWITCH CABLE CONNECTOR
7	2508611	REDUCER MOTOR SET
8	2508593	LONG NUT
9	2508651	MID COVER(2)
10	2508595	TOP OF MOTOR COVER
11	2508597	MID MOTOR COVER
12	2508581	MAIN MOTOR
13	2508598	LOW OF MOTOR
14	2508599	MASH COVER
15	2508652	END HEAD FRAME
16	2508658	SHAFT
17	2508655	SHAKE BAR
18	2508656	FILTER BRIDGE
19	2508657	THICK WASHER
20	2508619	SILICON RETAINER
21	2508571	HEPAR FITER
22	2508572	MAIN FILTER
23	2508584	SPRING
24	2508622	BLUE CHIP
25	2508660	BLUE CHIP FRAME
26	2508661	SHAKE BAR FRAME
27	2508662	RUBBER PACKING
28	2508663	GASKET
29	2508664	MAIN DRUM(2700AC)
30	2508635	SUCTION HOLE
31	2508665	HANDLE(2700AC)
32	2508666	CYCLONE COVER
33	2508667	DUST DRUM
34	2508627	HOOK CLAMP
35	2508631	DRUM HANDLE
36	2508668	TURN WHEEL 3"
37	2508669	WHEEL 5"
38	2508677	HOOK CLAMP BOTTOM
38	2508677	HOOK CLAMP BOTTOM

Additional Parts

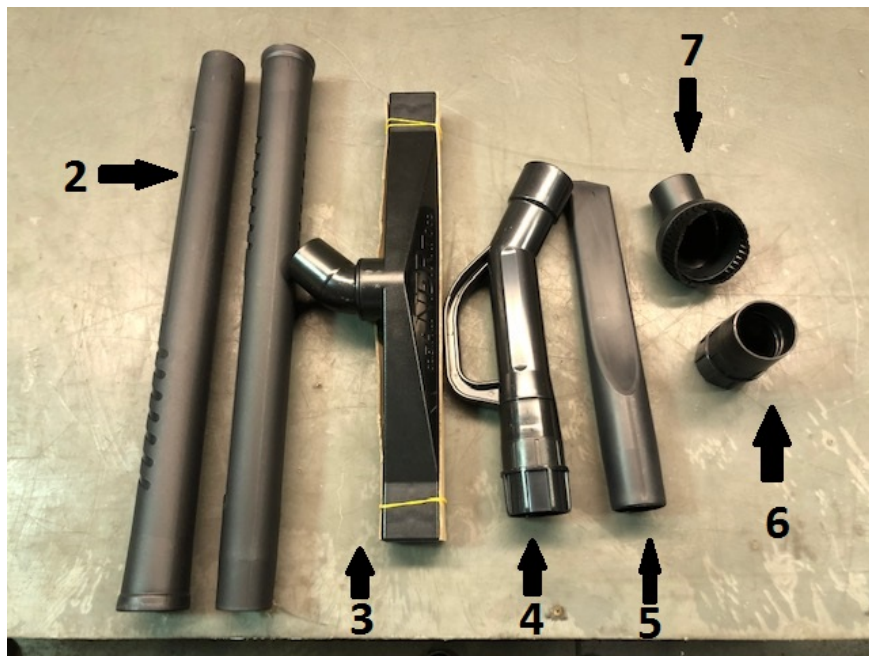

	DP #	DESCRIPTION
1	2508588	Hose(10m)
2	2508794	Pipe
3	2508795	Elongated Brush
4	2508796	Elbow
5	2508810	Nozzle
6	2508797	Hose socket
7	2508811	Circle brush

EQUIPMENT AND PARTS WARRANTY

Diamond Products warrants all equipment manufactured by it against defects in workmanship or materials for a period of 1 year from the date of shipment to Customer. The responsibility of Diamond Products under this Warranty is limited to replacement or repair of defective parts at Diamond Products' Elyria, Ohio factory, or at a point designated by it, of such parts as shall appear to us upon inspection at such parts, to have been defective in material or workmanship, with expense for transportation and labor borne by Customer. In no event shall Diamond Products be liable for consequential or incidental damages arising out of the failure of any Product to operate properly.

THIS WARRANTY IS IN LIEU OF ALL OTHER WARRANTIES, EXPRESSED OR IMPLIED, AND ALL SUCH OTHER WARRANTIES ARE HEREBY DISCLAIMED.



333 Prospect Street, Elyria, Ohio 44035
(440) 323-4616 • (800) 321-5336 • Fax (800) 634-4035
www.diamondproducts.com