



**CORE VAC  
OPERATOR'S MANUAL**

**CVG1  
GAS VAC**

**DECEMBER, 2023**



# Table of Contents

Table of Contents .....	3
Introduction .....	4
Overview .....	5
Safety Precautions .....	6
Proposition 65.....	6
Safety Alerts .....	6
General Safety.....	7
Battery and Electrical Safety.....	7
Engine Safety .....	8
Fuel Safety .....	8
Belt Safety .....	9
Transporting Safety .....	9
Lifting Safety.....	9
Operating .....	10
Starting Engine .....	10
Stopping the Engine .....	10
Shake Bar.....	10
NOTES FROM DIAMOND .....	10
Maintenance .....	11
General Maintenance .....	11
Engine Maintenance.....	11
Dust Drum Removal and InstallationDrum Removal .....	11
Drum Installation.....	11
Filter Maintenance .....	11
Filter Removal .....	11
Filter Installation .....	11
Agitator Adjustment/Replacement.....	12
Appendix B Serial Number .....	14

## **Introduction**

Welcome to the Diamond Products family and thank you for choosing Diamond Products equipment. At Diamond Products we are driven to ensure you are completely satisfied with your product and continually strive to improve our product line so that we can offer you the best possible equipment in the industry.

This operator's manual is a critical document that provides pertinent information regarding the safety, operation, maintenance, and care of your new equipment. Keep this manual available at all times. Operate the equipment and all of its components according to this manual. Failure to comply with and understand the following safety, operation and maintenance instructions can result in serious injuries and/or death. All operators must be properly trained or supervised by experienced personnel prior to using this equipment and should understand the risks and hazards involved. Diamond Products discourages improper or unintended equipment usage and cannot be held liable for any resulting damages.

Equipment modifications should be made by Diamond Products to ensure safety and design. Any modifications made by the owner(s) are not the responsibility of Diamond Products and void all equipment warranties if a problem arises as a result of the modification.

Refer to the Diamond Products Parts List for additional information and part diagrams. Refer to the engine/motor manual and manufacturer as the primary source for all safety, operations, and maintenance instructions regarding the engine/motor. Prior to operating, record the equipment's serial number, and the engine's/motor's model and serial numbers in Appendix B.

**Overview**

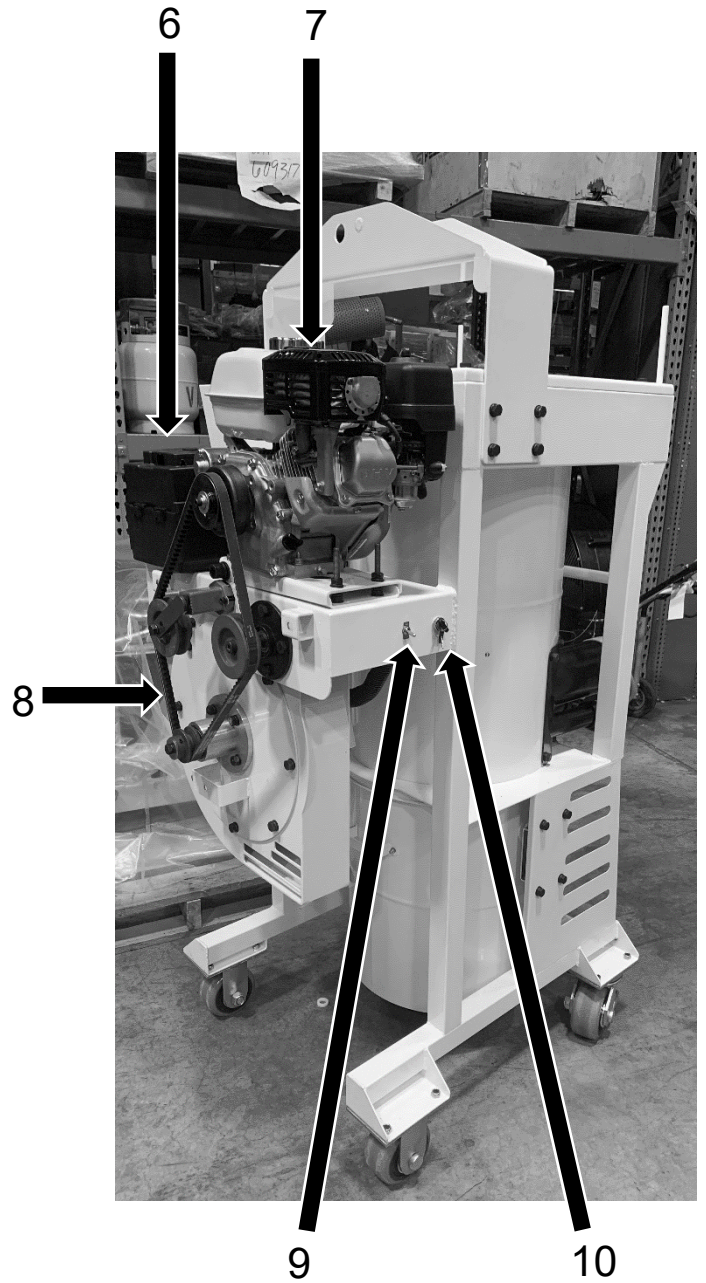
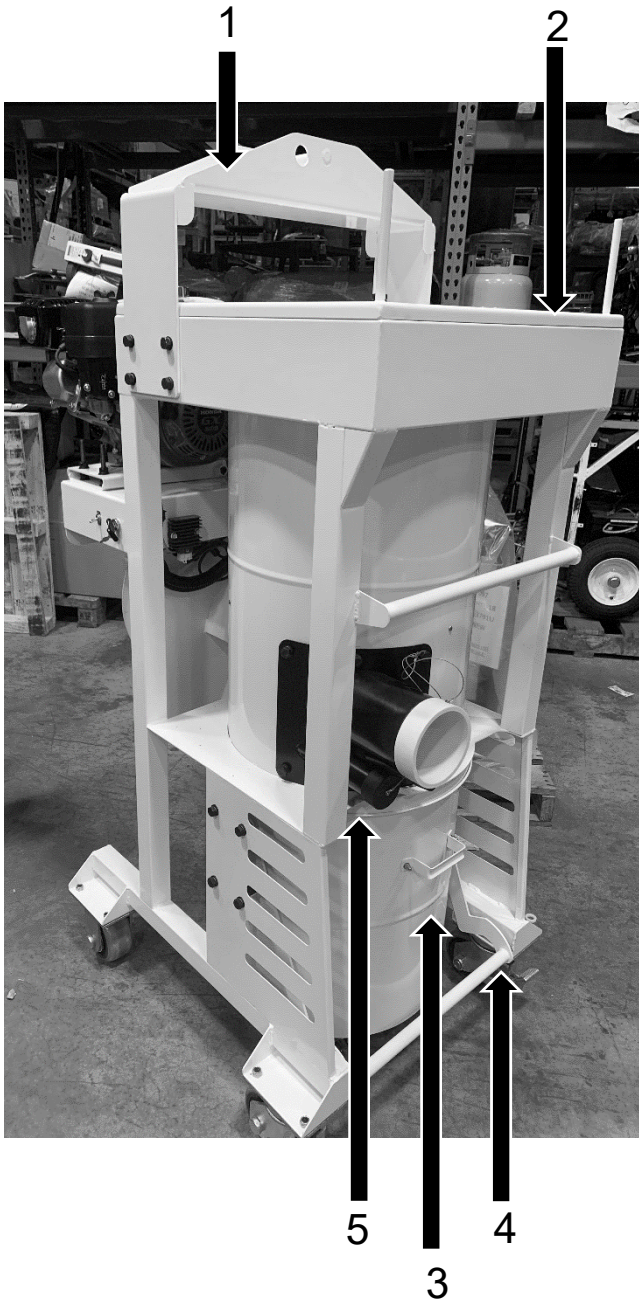

- 1). Lifting Frame
- 2). Lid
- 3). Dust Drum
- 4). Drum Handle
- 5). Intake

- 6). Battery Box
- 7). Engine
- 8). Belt
- 9). Shake Bar Switch
- 10). Ignition Switch

**Safety Precautions**

Operate the equipment and all of its components according to this manual. Failure to comply with and understand the following safety, operation and maintenance instructions can result in serious injuries and/or death. All operators must be properly trained or supervised by experienced personnel prior to using this saw and should understand the risks and hazards involved. Diamond Products discourages improper or unintended equipment usage and cannot be held liable for any resulting damages.

Equipment modifications should be made by Diamond Products to ensure safety and design. Any modifications made by the owner(s) are not the responsibility of Diamond Products and void all equipment warranties if a problem arises as a result of the modification.

Refer to the Diamond Products Parts List for additional information and part diagrams. Refer to the engine manual and manufacturer as the primary source for all safety, operations, and maintenance instructions regarding the engine. Prior to operating, record the saw's serial number, and the engine's model and serial numbers in **Error! Reference source not found.**

**Notice: The information in this manual may be updated at any time!**



**Safety Alerts**

 **DANGER**  
Serious injuries and/or death will occur if these instructions are not followed.

 **WARNING**  
Serious injuries and/or death could occur if these instructions are not followed.

 **CAUTION**  
Mild and/or moderate injuries could occur if these instructions are not followed.

**Proposition 65**

 **WARNING**  
Engine exhaust and some of its constituents are known to the State of California to cause cancer, birth defects, and/or other reproductive harm. 

**Spark Arrester Requirement**

 **WARNING**  
In the State of California it is a violation of section 4442 or 4443 to use or operate the engine on any forest-covered, brush-covered, or grass-covered land unless the engine is equipped with a spark arrester, as defined in section 4442, maintained in effective, working order or the engine is constructed, equipped, and maintained for the prevention of fire pursuant to section 4443.

**Respiratory Hazards**

 **WARNING**  
Concrete cutting produces dust and fumes known to cause illness, death, cancer, respiratory disease, birth defects, and/or other reproductive harm. Safety protection techniques include, but are not limited to:

- Wearing gloves.
- Wearing safety goggles or a face shield.
- Using approved respirators.
- Washing work clothes daily.
- Using water when wet cutting to minimize dust.
- Washing the hands and face prior to eating/drinking.

For additional safety and self-protection information contact your employer, the Occupational Safety and Health Administration (OSHA), and/or The National Institute for Occupational Safety and Health (NIOSH).

## **General Safety**

- Read and understand all safety, operations, and maintenance instructions provided in this manual prior to operating or servicing the saw.
- Keep equipment components clean and free of slurry, concrete dust, and debris.
- Inspect water hoses prior to operating the equipment. Clean, repair, or replace damaged components.
- Raise the equipment to a proper height for access when working underneath the equipment. Use chocks to block the wheels, and fit blocks or jacks under the frame edges.
- When using a jack to raise the equipment, place the jack against a solid, flat area under the frame base to properly support the equipment.
- Repair the equipment immediately when a problem arises.
- Replace equipment decals if unreadable.
- Dispose of all hazardous waste materials according to city, state, and federal regulations.
- Always have a phone nearby, and locate the nearest fire extinguisher and first aid kit prior to operating the equipment.
- Operate the equipment wearing flame resistant clothing.
- Always wear safety glasses when removing retaining rings.
- Persons under the statutory age limit should not operate the equipment.
- Keep all body parts away from rotating machinery.
- Replace all guards and access panels (unless stated otherwise) prior to operating the equipment.
- Chock the wheels to help prevent unnecessary movement.

### **DO NOT:**

- Drop equipment, supplies, tools, etc., when handling to help prevent injuries.
- Lift and carry equipment, supplies, tools, etc., that are too heavy and/or cannot be lifted easily.
- Operate the equipment without using the appropriate safety equipment required for the work task.



- Operate or service the equipment with any clothing, hair, or accessories that can snag in the machinery, which could lead to serious injuries or death!
- Operate the equipment using attachments not associated with or recommended for the equipment.
- Operate the equipment around combustible materials or fumes to prevent fires/explosions.
- Operate the equipment with anyone near the work area or within the direct line of the blade.
- Operate the equipment until all unnecessary materials have been removed from the work area.
- Operate the equipment with loose nuts, screws, and bolts.
- Operate the equipment when ill or fatigued.
- Operate the equipment under the influence of drugs and/or alcohol.
- Cut concrete with guards and access panels removed.
- Grease the equipment with the engine running.
- Touch hot components when operating the equipment.
- Leave the equipment unattended until the engine is off and the blade has stopped spinning.
- Place the equipment into storage until it has cooled down.
- Service the equipment until it has cooled down.
- Service the equipment with the engine running.

## **Battery and Electrical Safety**

- Ignitable explosive gases are emitted from the battery. **DO NOT** expose the battery to sparks or open flames.
- Keep the area around the battery well-ventilated.
- Keep the battery level when handling it.





- Use protective eyewear or a face shield, and avoid contact with the skin when handling/servicing the battery.
- Use a proper battery tester when testing the battery strength.
- Always be sure to connect the battery cables to the proper terminal when reconnecting the cables.
- Occasionally inspect the battery, cables, clamps, and terminals for damages. Service components as necessary.
- Always keep the battery cable clamps away from the battery terminals when the battery is disconnected to avoid accidental connections while servicing.
- Immediately rinse your clothing, skin, or eyes with water if exposed to battery acid. Seek medical attention immediately!
- Disconnect the battery prior to servicing all equipment components (unless stated otherwise).
- Remove the battery when storing the equipment for longer periods.
- Always use the correct size fuses (amps) to prevent fires.

## **Fuel Safety**

- Always use caution when refueling.
- Store all fuel in appropriate safety containers.
- DO NOT operate the equipment with a fuel leak.
- DO NOT fuel the equipment with the engine running.
- Let the engine cool prior to adding fuel.
- Refer to the engine manual for recommended fuels.
- Always use appropriate fuels in cold weather.
- Move the equipment away from the refueling area prior to starting the engine.

- 
- DO NOT smoke or expose fuel to open flames when filling the fuel tank or working with fuel.



- Clean up any spilled fuel prior to starting the engine.
- Drain the fuel tank and fuel lines when storing the equipment for longer periods of time. Refer to the engine manual for additional recommendations.

## **Engine Safety**

- Refer to the engine manual as the primary source for engine safety.
- Always know how to turn off the engine quickly for emergency purposes.
- Make sure the equipment is in neutral when starting the engine.
- Fill the fuel tank and check the oil level prior to starting the engine.

- 
- Keep all body parts away from rotating equipment parts with the engine running.



- 
- DO NOT start the engine without the air filter(s) installed.
  - DO NOT allow dust to enter the air intake tube when cleaning/replacing air filter(s).
  - Replace damaged components immediately that may allow dust to enter the engine.
  - DO NOT leave the engine running unattended.

- 
- Always operate the equipment in well-ventilated areas. Concentrated engine exhaust can cause loss of consciousness and/or death.



- 
- DO NOT touch the engine/muffler assembly with the engine running, and always let them cool down prior to touching or servicing the equipment.
  - Handle hot oil carefully when changing the oil.
  - Let the engine cool prior to removing pressurized caps (applicable models).
  - DO NOT use any starter substances or starter fluids (e.g., starter fluid sprayed into the air filter) when starting the engine using a glow plug (applicable models). These materials are extremely flammable and explosive, and can melt parts or possibly explode when used to help start the engine.
  - DO NOT expose yourself or anyone else to the direct line of the blade when operating the equipment.
  - DO NOT allow any person, animal, and/or objects in and around the work area while cutting.



## **Belt Safety**

- Turn off the engine and let the belts cool down prior to servicing them.
- Regularly inspect the belts for fraying, stress cracks, and/or breakage and replace immediately when damaged. Always check the belt alignment prior to operating the equipment.
- Use extreme caution when working with belts and rotating machine parts to avoid entanglement.
- Over-tensioning belts may reduce the life of the gearbox bearings. Under-tensioning belts may cause slippage, shorter belt life, and/or poor equipment performance.
- Squealing belts indicate looseness.
- DO NOT use old and new belts together on the same sheave.
- Raise the equipment to avoid damaging components while moving up and down ramps.

- 
- Use extreme caution when guiding the equipment up and down ramps. Slowly drive the equipment forward down the ramp. Slowly back the equipment in reverse up the ramp. Avoid standing directly downhill from the equipment to prevent machine rollover.



## **Transporting Safety**

- Remove the blade prior to transporting the equipment.
- Make sure the truck/trailer is in good, working condition and sufficient to transport

## **Lifting Safety**

- 
- Move yourself and all others away from the lifting area when hoisting the saw to prevent being crushed.
- 
- Secure the appropriate hoisting cables, straps, and/or chains to the saw's designated lift points prior to hoisting.
  - Never use the tie-down brackets (applicable models) to lift the saw.
  - DO NOT attempt to lift the saw irresponsibly and/or improperly.



## Operating

### Starting Engine

1. Remove at least one cap from the intake before starting engine.
2. Slide the throttle to about 1/3 from MIN to MAX.

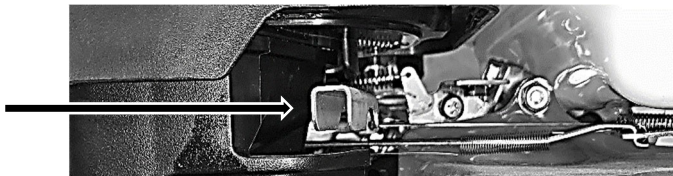

Throttle

3. Close the choke (When warm, open the choke).



Choke

4. Slide the fuel shutoff lever to the ON position.

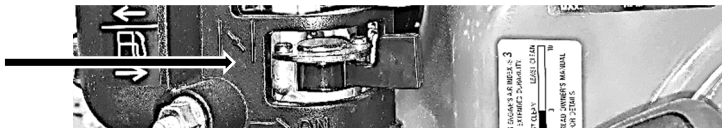

Fuel Shutoff Lever

5. Ensure the silver battery connector is plugged in.
6. Turn the ignition switch (4) to the on position and either pull the recoil starter or turn the ignition switch to start. (If the engine does not start in 5 seconds, release the key for 10 seconds and try again.)



Ignition Switch

7. Open the choke as the engine warms up.
8. Slide the throttle to the MAX.

(Refer to the engine manual if engine does not start after multiple attempts)

### Stopping the Engine

In an emergency, simply turn the ignition switch to the off position, otherwise follow the instructions below

1. Move the throttle to the MIN position.
2. Turn the ignition switch to the OFF position.
3. Slide the fuel shutoff lever to the OFF position.

### Shake Bar

- Keep the auto cleaner switch to the ON position while the vacuum is in use. (The switch can be shut off periodically if the work is light duty)
- Keep the auto cleaner switch to the ON position for 15 minutes after operation to clean the filter of any leftover debris.

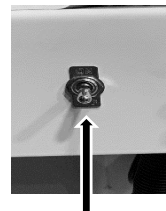

Auto Cleaner Switch

### NOTES FROM DIAMOND

- The battery will be disconnected by a silver connector upon first arrival.
- The hose will be located in the drum.
- The clutch will not engage until the throttle is half open.

## **Maintenance**

### **General Maintenance**

- Check belt of any burrs or breaks.
- Check the condition of the main filter.
- Look for any loose bolts or any damages on the vacuum.

### **Engine Maintenance**

Refer to engine manual for a detailed maintenance schedule

- Clean air filter after every use.
- Check engine oil before use.
- Change engine oil after first 20 hours, every 100 hours after.

### **Dust Drum Removal and Installation**

#### **Drum Removal**

1. Have the casters parallel with the frame.
2. Raise the handle so the knobs on the handle are horizontal.
3. Roll the drum out from underneath the vacuum.



Drum handle raised

Drum handle lowered

#### **Drum Installation**

1. Have casters parallel with the frame
2. Roll the drum underneath the vacuum, with the knobs horizontal..
3. Guide the drum so that knobs on both sides go into the lever support.
4. Push the drum until the rear knob touched the back of the lever support
5. Pull the handle down, so the knobs are vertical.

### **Filter Maintenance**

- The filter should be replaced when the vacuum is performing poorly and the shake bar is no longer working efficiently.

#### **Filter Removal**

1. Remove lid and lift bracket.
2. Disconnect the plug for the motor wires.
3. Remove the outer 6 nuts and remove the filter/motor assembly.

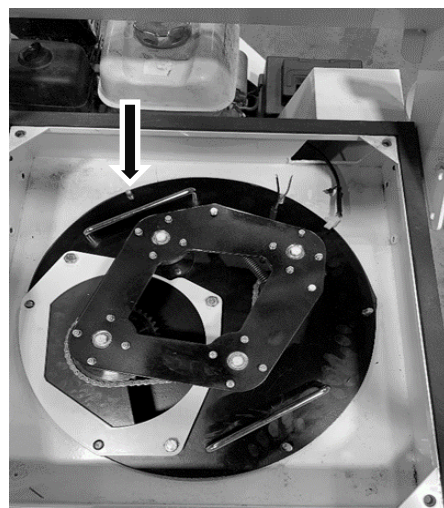

CVG1 with Lid removed

4. Remove the 4 wingnuts holding the filter plates down onto the filters. Spin filters clockwise as you pull them up so they don't catch on the shaker bars.

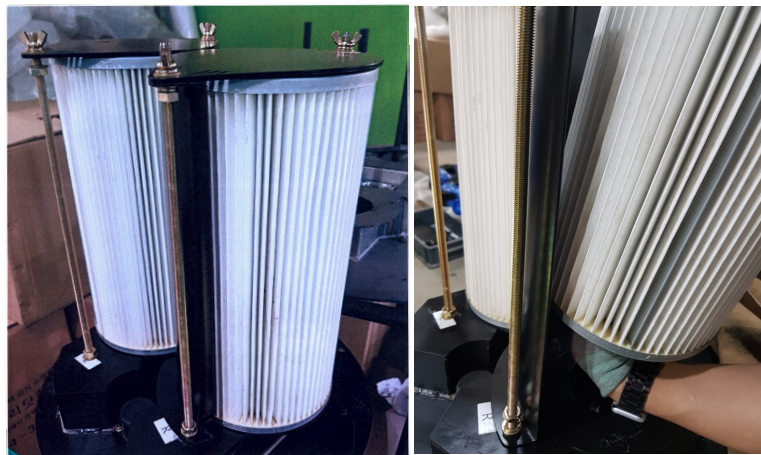

#### **Filter Installation**

1. Repeat the removal steps, but in reverse order.



**Agitator Adjustment/Replacement**

1. Remove Filter assembly (see Page 11).
2. Remove filters (see Page 11).



3. Remove the nuts and bolts holding the chip to the bracket

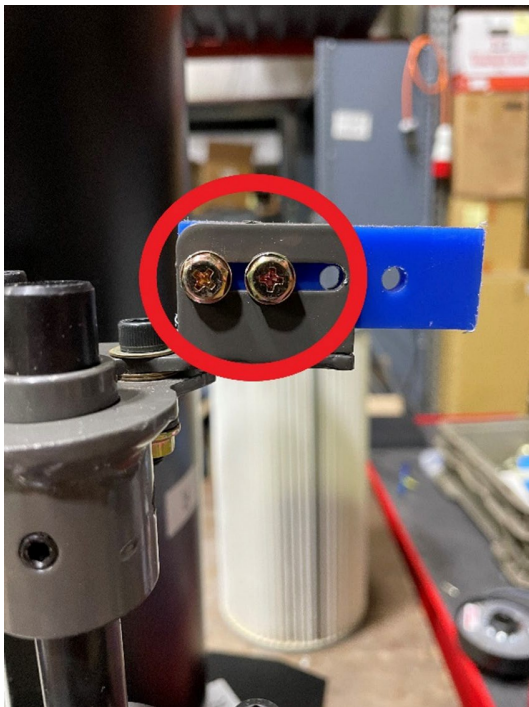

4. If the chip is too aggressive on the filter, slide the chip so that there is less contact.
5. If the chip is not making enough contact, adjust the chip so that there is more contact.

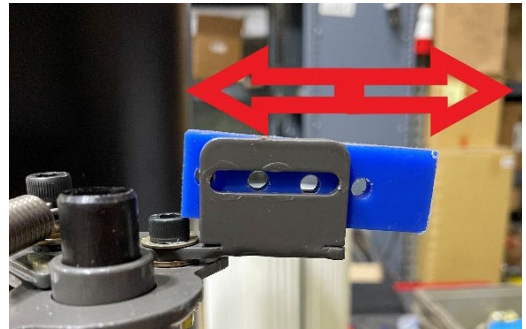

6. If the chip is broke or worn down, replace chip.
7. Assemble in reverse order.

**References****Appendix A****Troubleshooting**

<b>Troubleshooting the CVG1 Gas Vac</b>		
<b>Symptom</b>	<b>Problem</b>	<b>Solution</b>
1. Engine will not start	Fuel Valve open?	Turn on Fuel Valve
	Choke on?	Turn on Choke
	Starter Fuse blown?	Replace fuse
	Battery Dead?	Replace battery or put on a charger.
2. Vacuum not performing correctly	Filter clogged?	Replace filter or run the shake bar for 15 minutes.
	Shake Bar turned on?	Turn on the Shake bar while running the vacuum
	Engine full throttle?	Open the throttle all the way to the MAX
3. Shake Bar will not turn on	Battery Dead?	Replace battery or put on a charger
	Shake Bar fuse blown	Replace fuse

Contact Diamond Products Technical Service at 1-800-321-5336

**Appendix B**

**Serial Number**

Record the CVG1's serial number below for future reference and customer service purposes.

The serial number is located below the battery box.

Serial Number	
---------------	--





## **EQUIPMENT AND PARTS WARRANTY**

Diamond Products warrants all equipment manufactured by it against defects in workmanship or materials for a period of one (1) year from the date of shipment to Customer.

The responsibility of Diamond Products under this Warranty is limited to replacement or repair of defective parts at Diamond Products' Elyria, Ohio factory, or at a point designated by it, of such parts as shall appear to us upon inspection at such parts, to have been defective in material or workmanship, with expense for transportation and labor borne by Customer.

In no event shall Diamond Products be liable for consequential or incidental damages arising out of the failure of any Product to operate properly.

Integral units such as engines, electric motors, batteries, transmissions, etc., are excluded from this Warranty and are subject to the prime manufacturer's warranty.

**THIS WARRANTY IS IN LIEU OF ALL OTHER WARRANTIES, EXPRESSED OR IMPLIED, AND ALL SUCH OTHER WARRANTIES ARE HEREBY DISCLAIMED.**



333 Prospect Street, Elyria, Ohio 44035  
(440) 323-4616 • (800) 321-5336 • Fax (800) 634-4035

[www.diamondproducts.com](http://www.diamondproducts.com)