



**CORE VAC  
PARTS LIST**

**CVG1 PRO  
GAS VAC**

**JANUARY, 2024**



# Table of Contents

## Contents

Frame .....	4
Filter Tank .....	5
Filter Cleaner .....	6
Chain Cover .....	7
Chain Tensioner .....	8
Rotation Plate Guard .....	9
Filter Plate .....	10
Rotation Plate .....	11
Filter Cleaner Base .....	12
Filter Shake Bar Shaft Set .....	13
Motor and Gearbox .....	14
Shake Bar .....	15
Pulley Assembly .....	16
Impeller Housing .....	17
Impeller .....	18
Dust Drum .....	19
Hose Inlet .....	20
Engine .....	21

# Frame

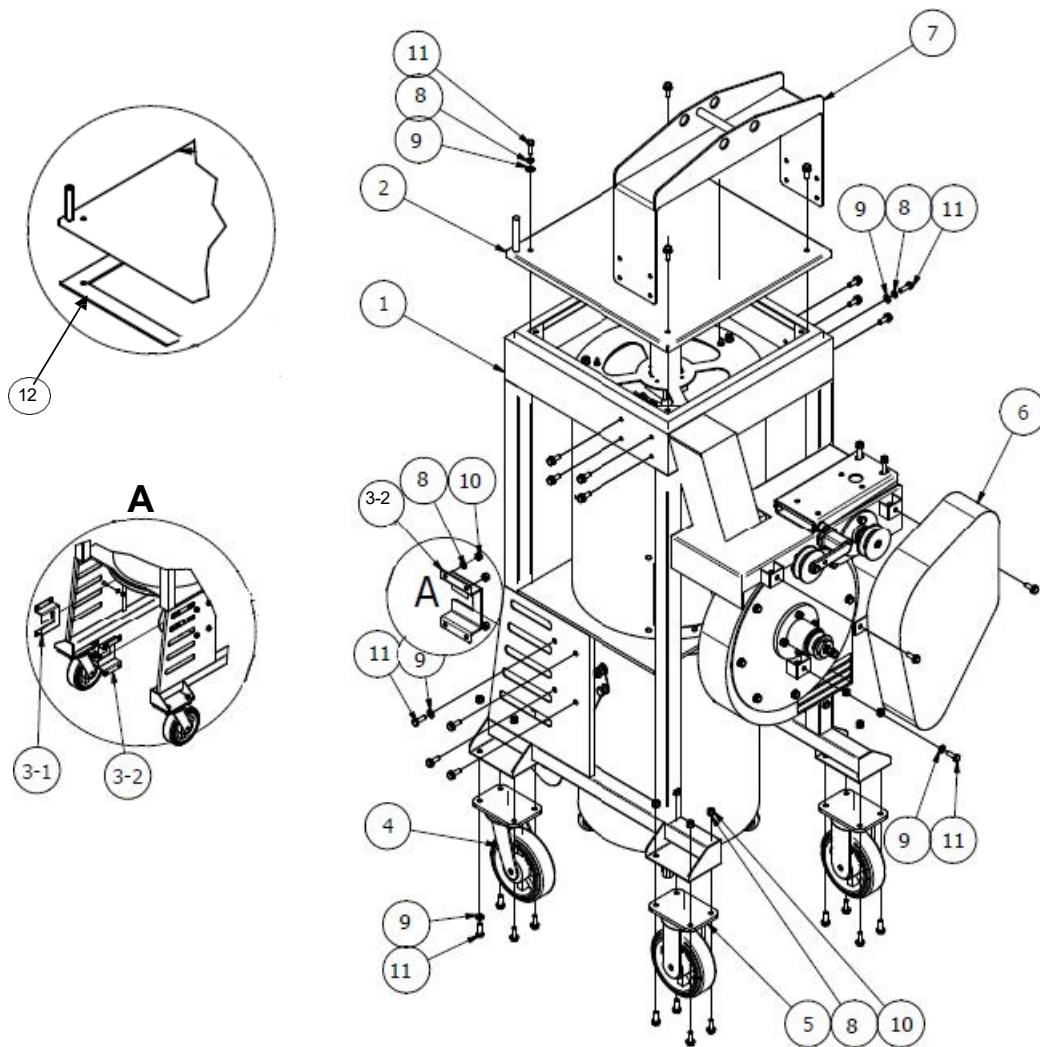

ITEM	DP#	QTY	DESCRIPTION
1	2508931	1	MAIN FRAME
2	2508837	1	UPPER TANK LID
3-1	2508832	1	LEVER SUPPORT STAND LEFT
3-2	2508833	1	LEVER SUPPORT STAND RIGHT
4	2508834	2	SWIVEL WHEEL 6"
5	2508835	2	WHEEL 6"
6	2508849	1	BELT COVER
7	2508847	1	UPPER LIFTING STAND
8	2508884	37	M10 SPRING WASHER
9	2508885	64	M10 WASHER
10	2508886	27	M10 NUT
11	2508887	39	M10 X 30 BOLT
12	2508689	1	LID SEAL
13	1802924	1	DECAL SET FOR CVG1 (NOT SHOWN)

# Filter Tank

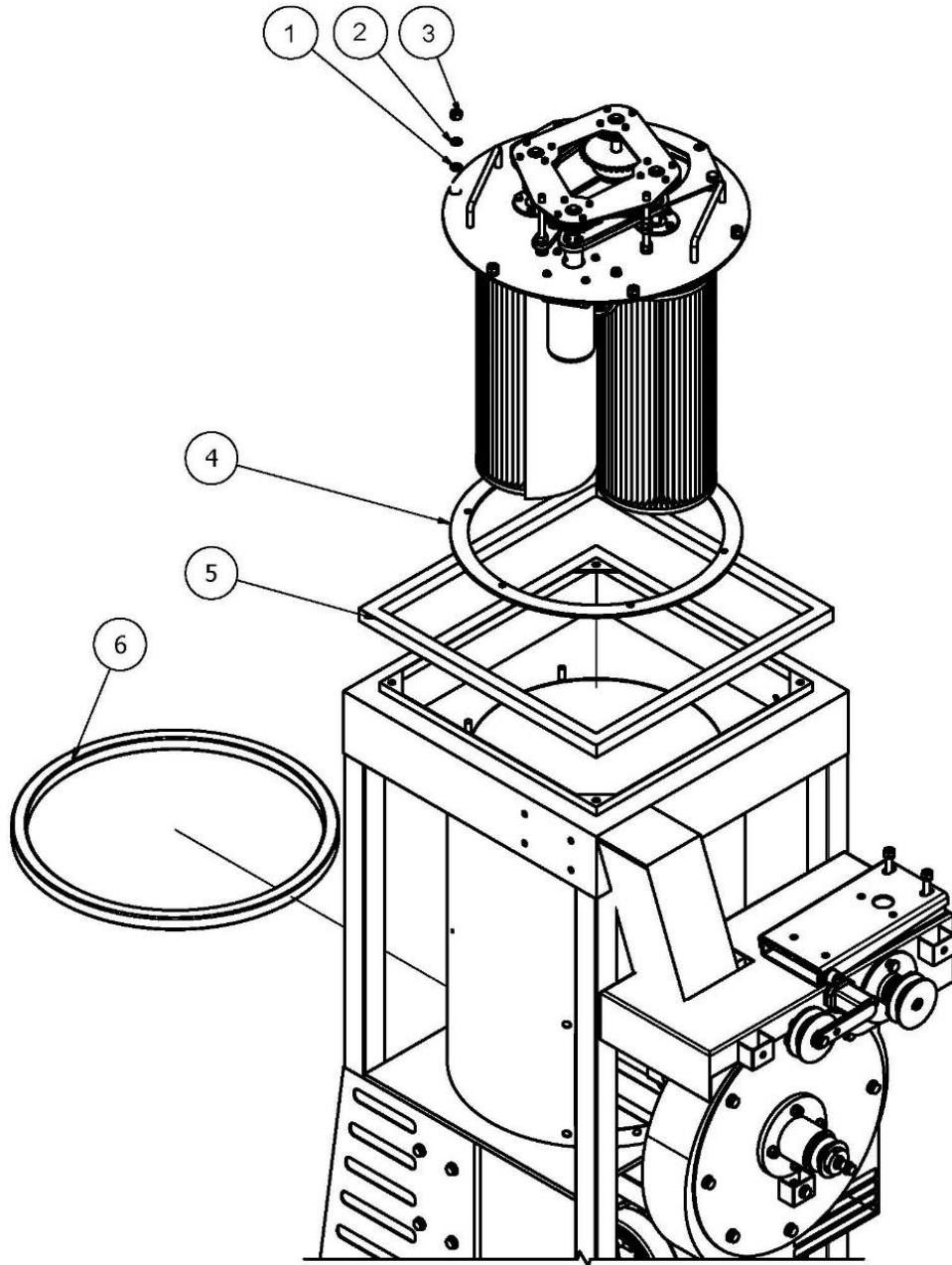

ITEM	DP #	QTY	DESCRIPTION
1	2508885	6	M10 WASHER
2	2508884	6	M10 SPRING WASHER
3	2508886	6	M10 NUT
4	2508853	1	FILTER PLATE SEAL
5	2508843	1	UPPER COVER SEAL
6	2508844	1	DUST DRUM SEAL

# Filter Cleaner

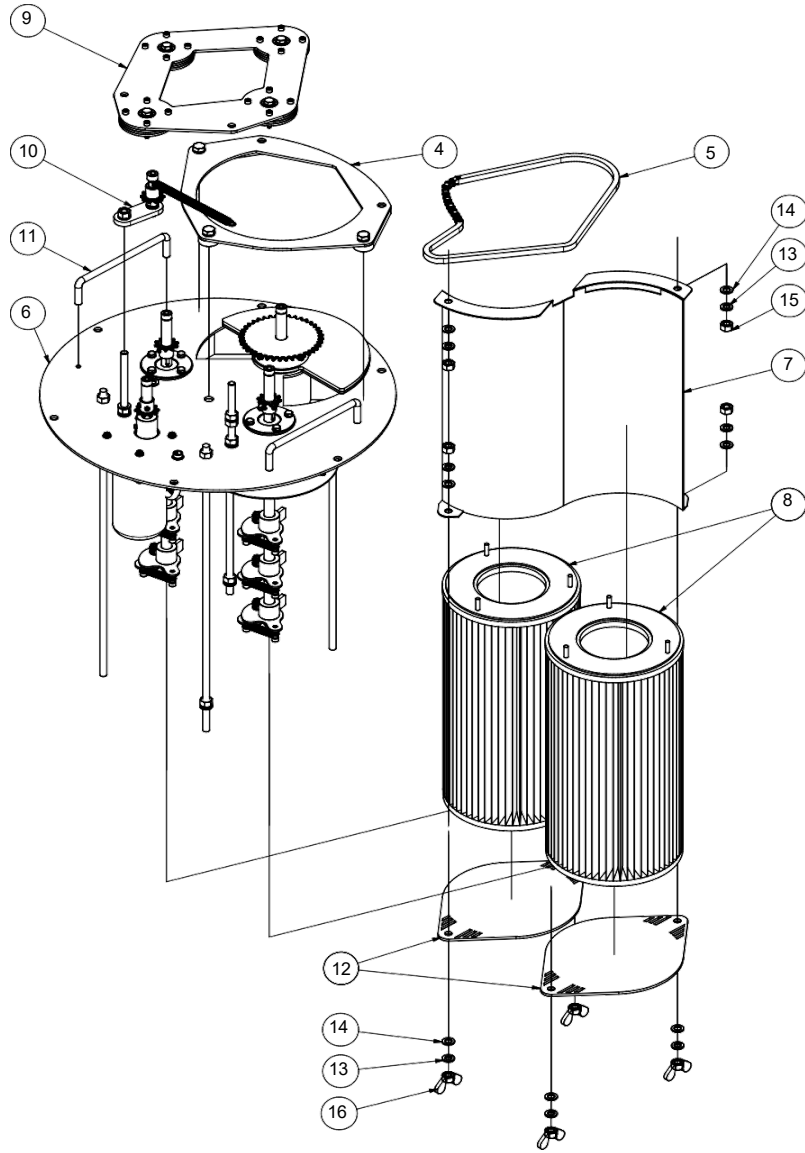

ITEM	DP#	QTY	DESCRIPTION
1	2508747	4	M8X16 BOLT
2	2509155	4	M8 SPRING WASHER
3	2508891	4	M8 WASHER
4	2508715	1	ROTATION RAIL PLATE COVER SET
5	2508949	1	CHAIN
6	2508723	1	FILTER PLATE SET
7	2505593	1	FILTER COVERS COMBINED
8	2508947	2	TWIN MAIN FILTER
9	2508705	4	CHAIN COVER SET
10	2507810	1	CHAIN TENSION SET
11	2508714	1	FILTER HANDLE
12	2505594	1	FILTER COVER BOTTOM
13	2508884	8	M10 SPRING WASHER
14	2508885	8	M10 WASHER
15	2508886	4	M10 NUT
16	2901340	4	M10 WING NUT

# Chain Cover

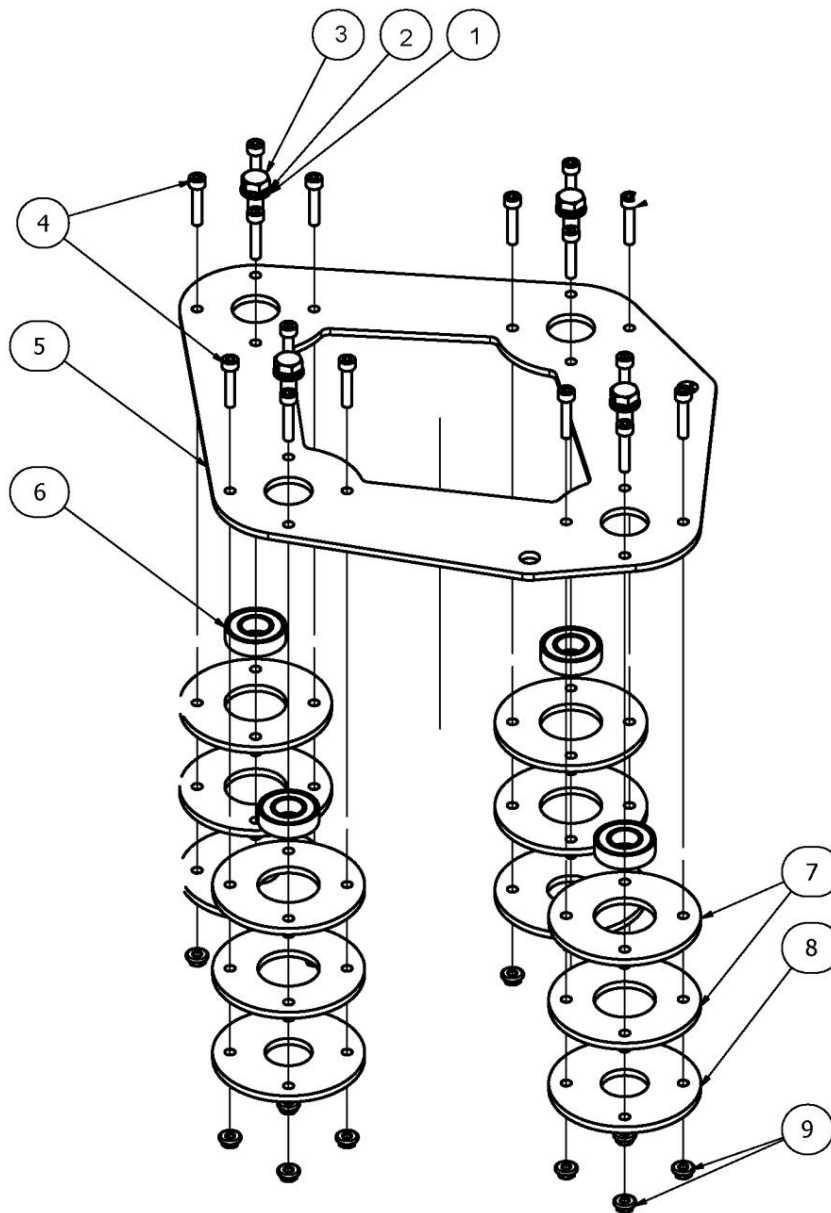

ITEM	DP #	QTY	DESCRIPTION
1	2508891	4	M8 WASHER
2	2509155	4	M8 SPRING WASHER
3	2508747	4	M8X16 BOLT
4	2508748	16	M5X25 HEX BOLT
5	2508706	1	CHAIN COVER PLATE
6	2508707	4	SUPPORT BEARING
7	2508708	4	COVER BEARING HOUSING 1
8	2508709	8	COVER BEARING HOUSING 2
9	2508894	16	M5 FLANGE NUT

# Chain Tensioner

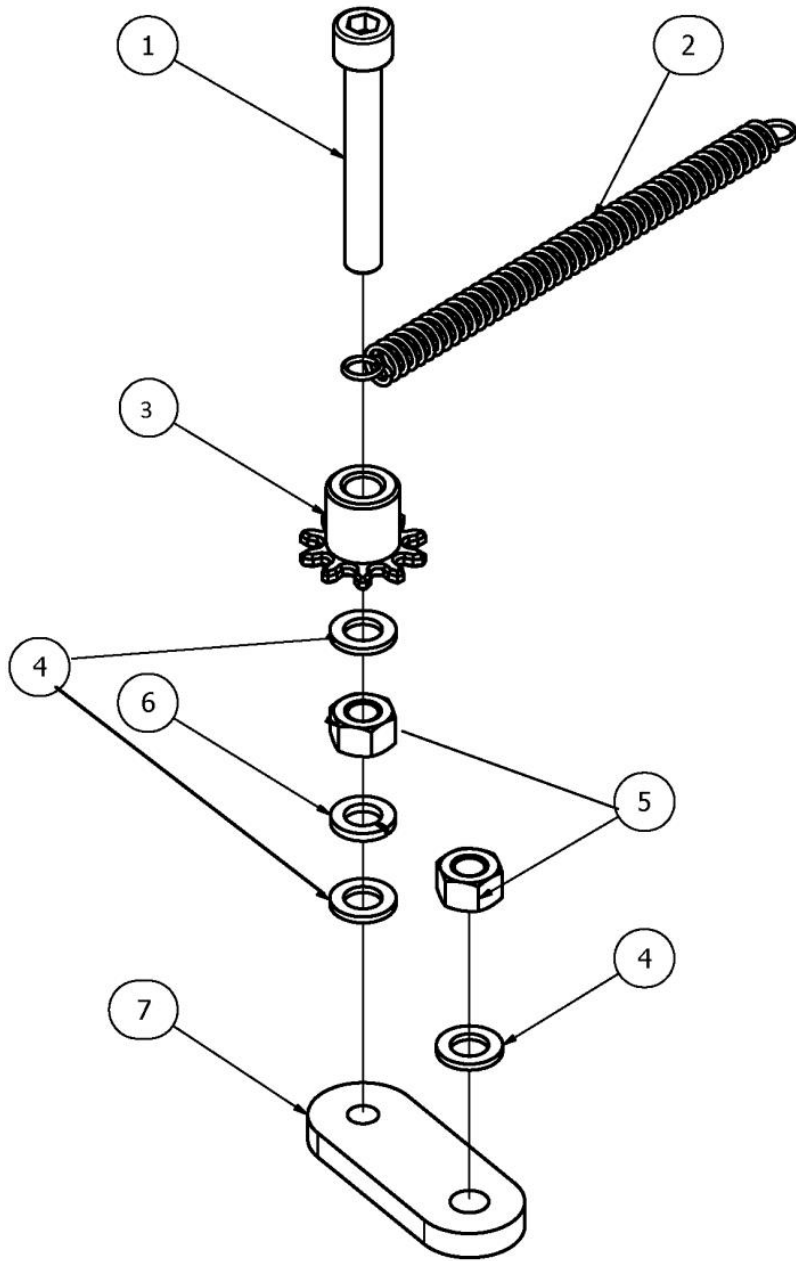

ITEM	DP #	QTY	DESCRIPTION
1	2508750	1	M10X70 HEX BOLT
2	2508712	1	CHAIN TENSION SPRING
3	2507813	1	CHAIN TENSION GEAR
4	2508885	3	M10 WASHER
5	2508886	2	M10 NUT
6	2508884	1	M10 SPRING WASHER
7	2508711	1	CHAIN TENSION PLATE



# Rotation Plate Guard

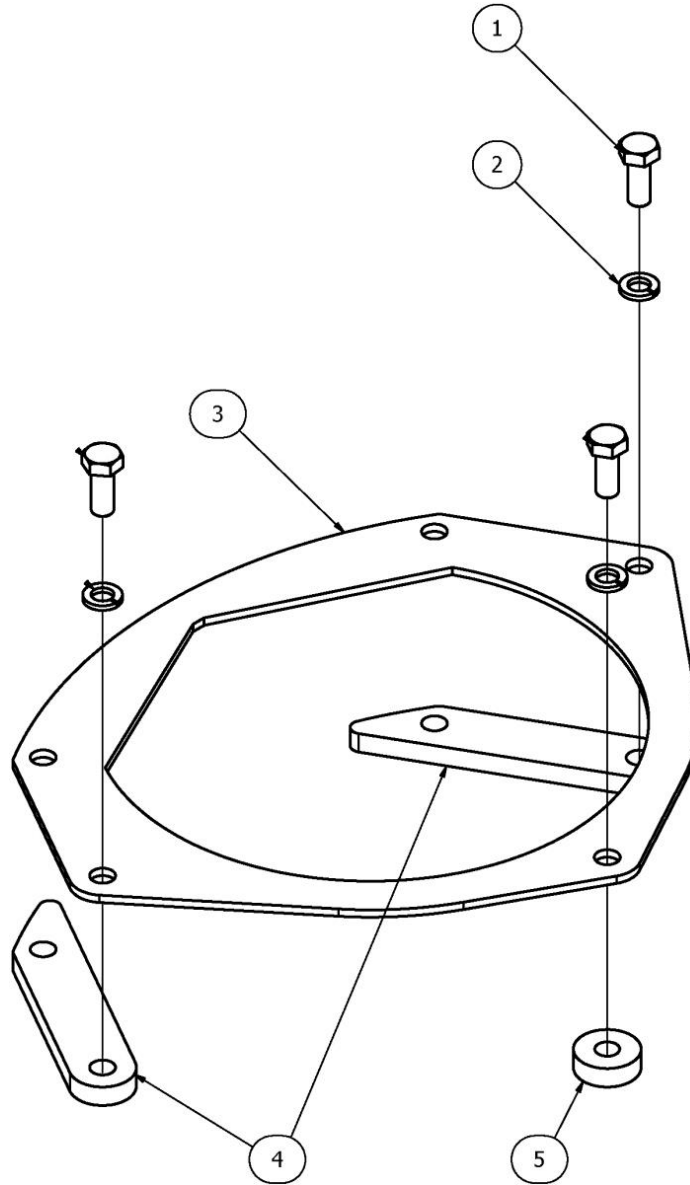

ITEM	DP #	QTY	DESCRIPTION
1	2508749	3	M10X25 BOLT
2	2508884	3	M10 SPRING WASHER
3	2508716	1	ROTATION RAIL PLATE COVER
4	2508717	2	ROTATION PLATE RAIL SPACER 1
5	2508718	1	ROTATION PLATE RAIL SPACER 2

# Filter Plate

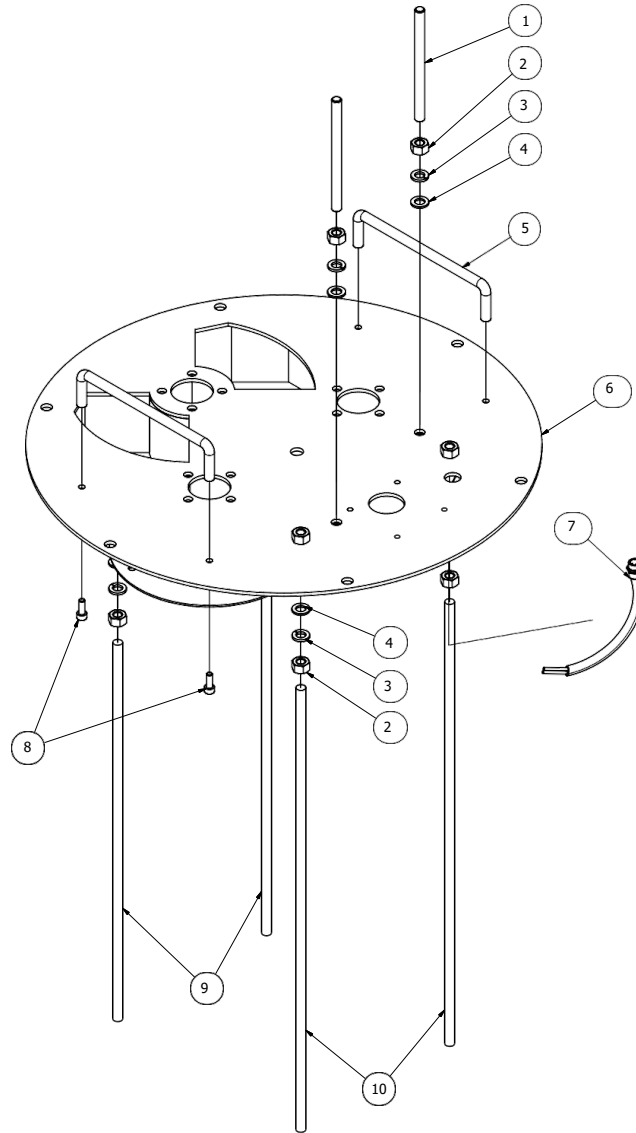

ITEM	DP #	QTY	DESCRIPTION
1	2508751	2	M10X135 FULL THREADED BOLT
2	2508886	4	M10 NUT
3	2508884	4	M10 SPRING WASHER
4	2508885	4	M10 WASHER
5	2508714	2	FILTER HANDLE
6	2508724	1	FILTER PLATE
7	2508725	1	TERMINAL SET
8	2508752	4	M6X16 SOC SCREW
9	2505597	2	M10 X 540 FULL THREADED BOLT
10	2505596	2	M10 X 560 FULL THREADED BOLT

# Rotation Plate

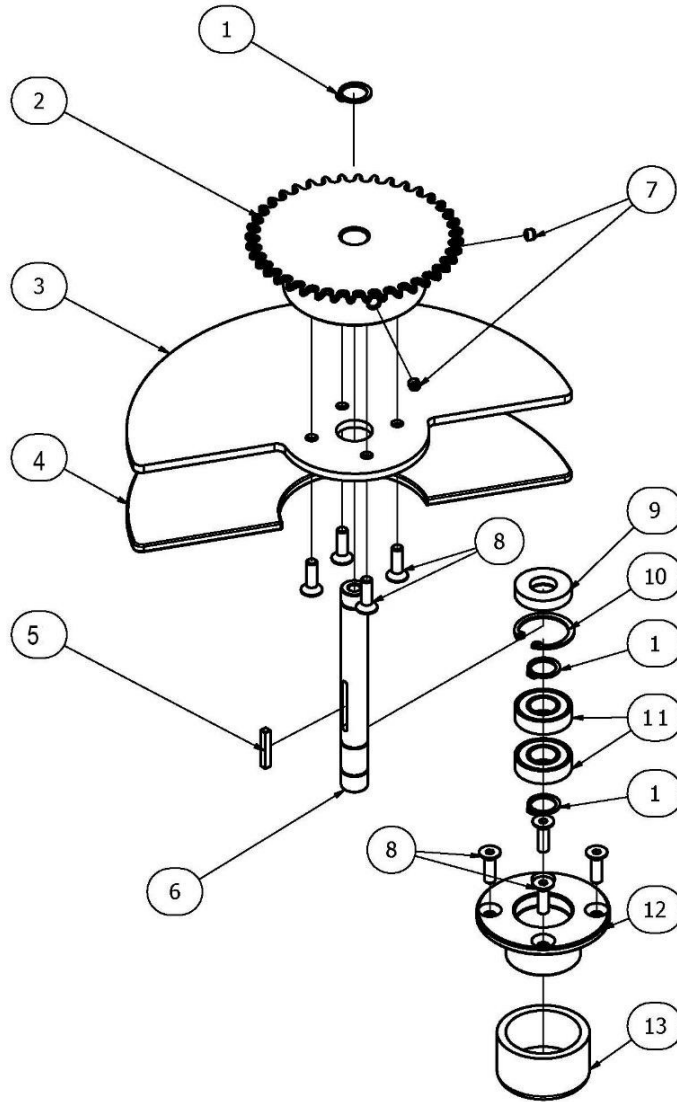

ITEM	DP #	QTY	DESCRIPTION
1	2508727	3	RETAINING RING 15 (C TYPE OUTSIDE)
2	2508735	1	GEAR 35B 40
3	2508736	1	ROTATION PLATE
4	2508737	1	ROTATION PLATE RUBBER
5	2508729	1	KEY 4 X 4
6	2508738	1	SHAFT(SHORT)
7	2508753	2	M6X8 SET SCREW
8	2508754	8	M6X20 FLAT HEAD SOC SCREW
9	2508730	1	15X32X7 RETAINER SEAL
10	2508731	1	RETAINING RING 32 (C TYPE INSIDE)
11	2508707	2	SUPPORT BEARING
12	2508740	1	ROTATION PLATE BEARING HOUSING
13	2508739	1	RUBBER CAP

# Filter Cleaner Base

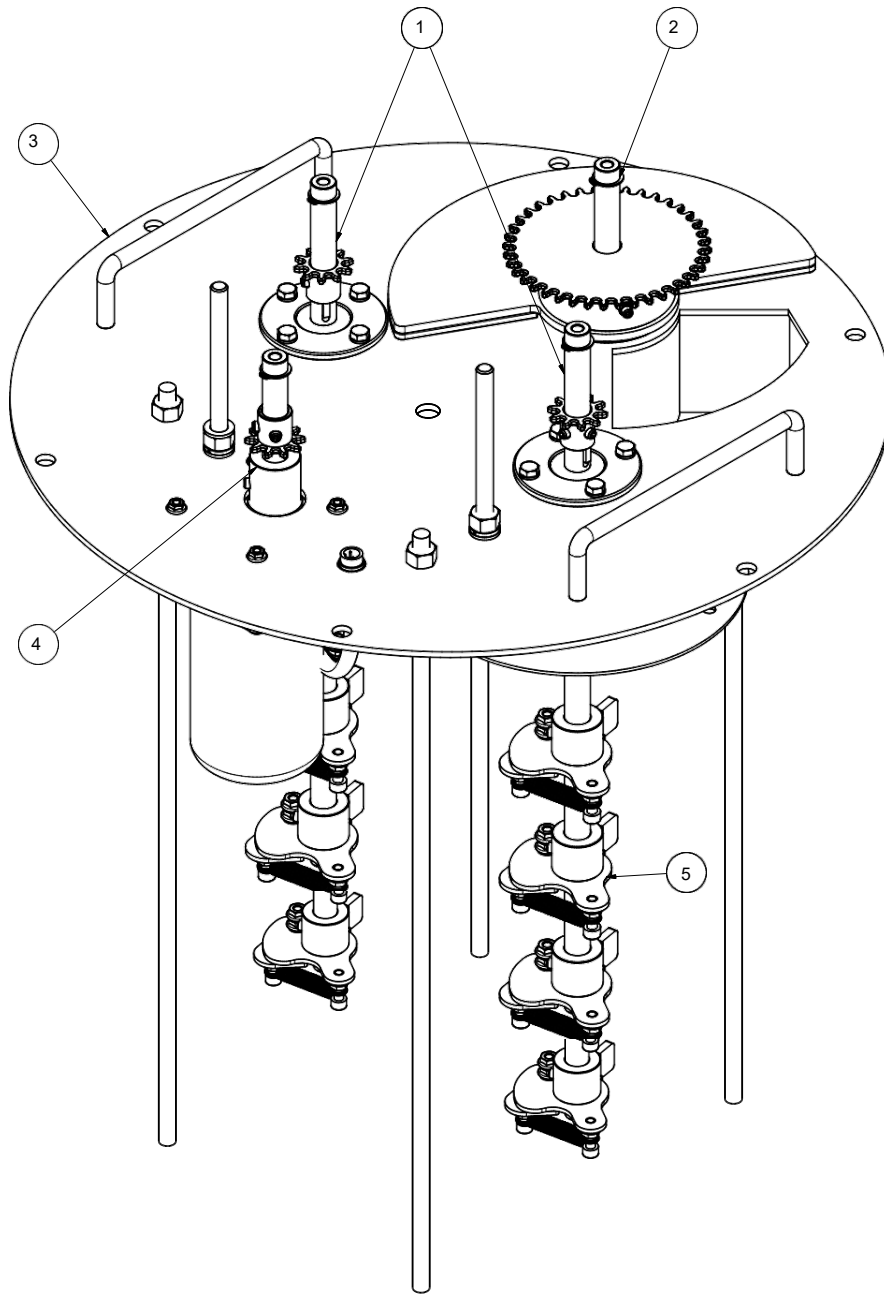

ITEM	DP #	QTY	DESCRIPTION
1	2508726	2	FILTER SHAKE BAR SHAFT SET (SEE NEXT PAGE)
2	2508734	1	ROTATION PLATE SET
3	2508723	1	FILTER PLATE SET
4	2508741	1	REDUCER MOTOR PART
5	2508743	8	SHAKE BAR

# Filter Shake Bar Shaft Set

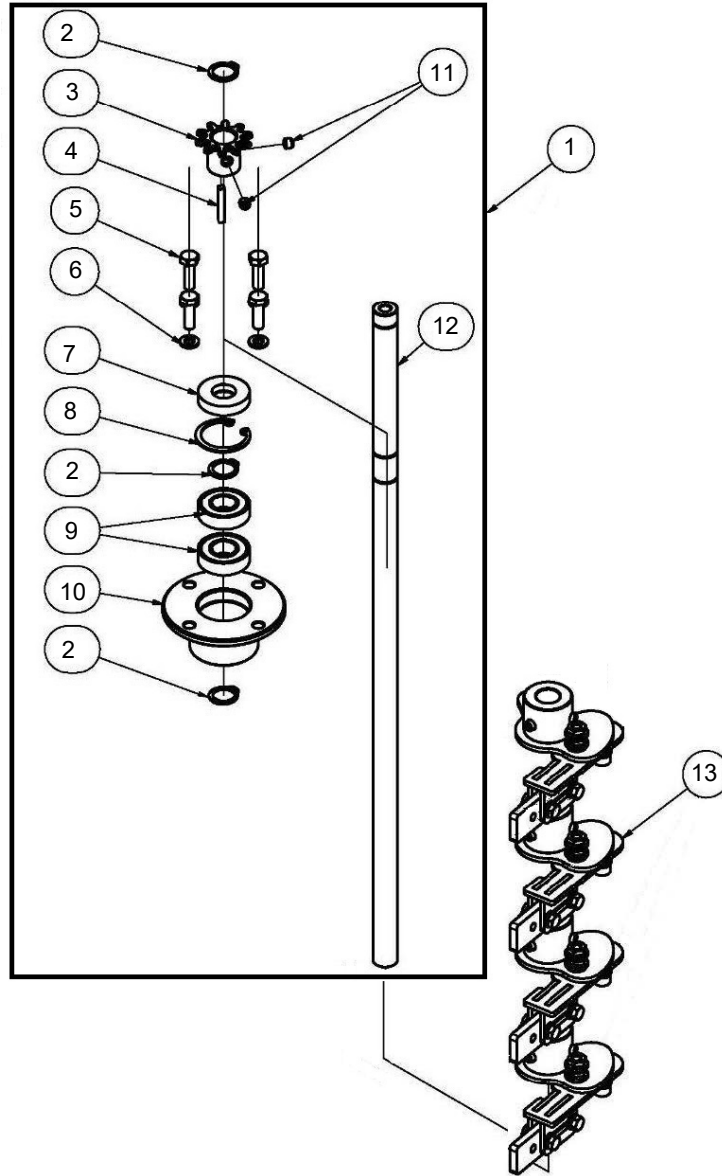

ITEM	DP #	QTY	DESCRIPTION
1	<b>2508726</b>	2	<b>FILTER SHAKE BAR SHAFT SET (INCLUDES ITEMS 2-12)</b>
2	2508727	3	RETAINING RING 15 (C TYPE OUTSIDE)
3	2508728	1	CHAIN GEAR 35B 12
4	2508729	1	KEY 4 X 4
5	2508758	4	M6X20 BOLT
6	2508889	4	M6 WASHER
7	2508730	6	15X32X7 RETAINER SEAL
8	2508731	1	RETAINING RING 32 (C TYPE INSIDE)
9	2508707	2	SUPPORT BEARING
10	2508732	1	GEAR BEARING HOUSING
11	2508753	2	M6X8 SET SCREW
12	2508733	1	SHAKE BAR SHAFT(LONG)
13	2508743	8	SHAKE BAR (4 REQUIRED PER SHAFT)

# Motor and Gearbox

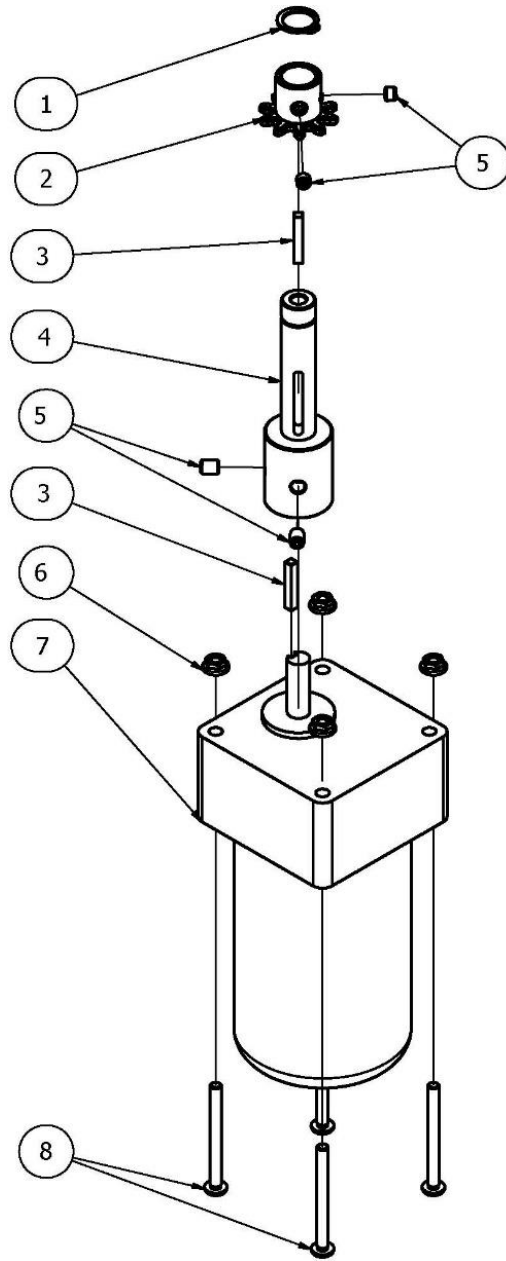

ITEM	DP #	QTY	DESCRIPTION
1	2508727	1	RETAINING RING 15 (C TYPE OUTSIDE)
2	2508728	1	CHAIN GEAR 35B 12
3	2508729	2	KEY 4 X 4
4	2508742	1	SHAFT (MOTOR AXIS)
5	2508753	4	M6X8 SET SCREW
6	2508755	4	M5 MOTOR NUT
7	2508838	1	REDUCER MOTOR SET
8	2508756	4	M5X55 MOTOR BOLT

# Shake Bar

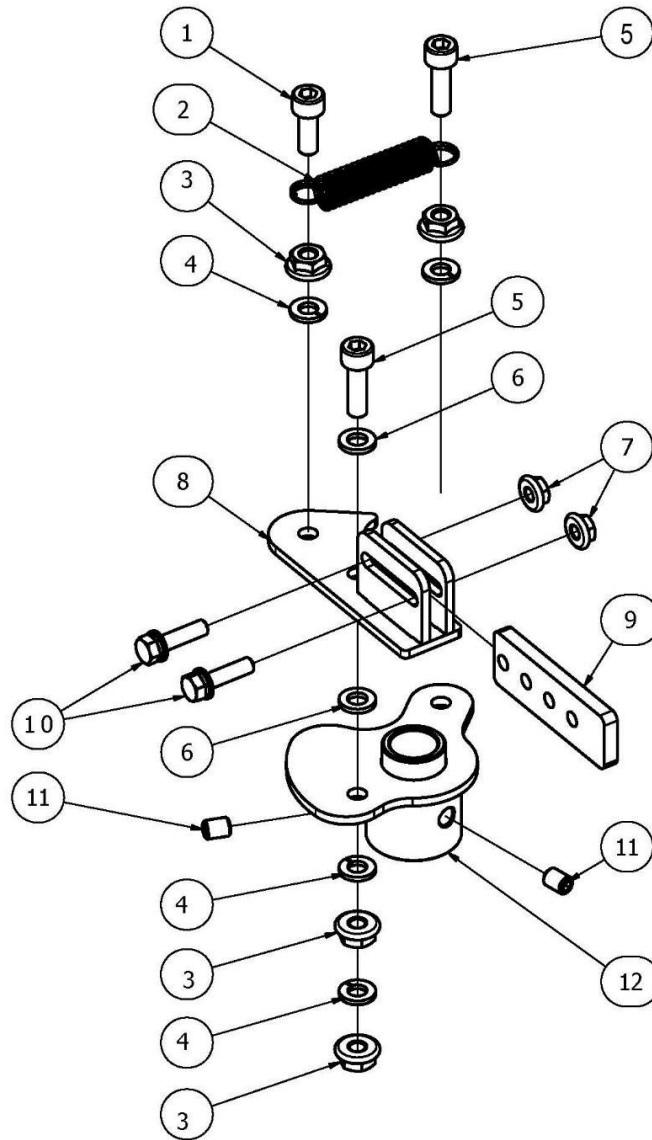

ITEM	DP #	QTY	DESCRIPTION
1	2508890	1	M6X15 SOC SCREW
2	2508584	1	SPRING
3	2508888	4	M6 NUT
4	2509147	4	M6 SPRING WASHER
5	2508757	2	M6X20 SOC SCREW
6	2508889	2	M6 WASHER
7	2508894	2	M5 FLANGE NUT
8	2508744	1	SHAKE BAR BRACKET
9	2508746	1	FLAT BLUE CHIP
10	2508895	2	M5 BOLT SET
11	2508753	2	M6X8 SET SCREW
12	2508745	1	SHAKE BAR COLLAR

# Pulley Assembly

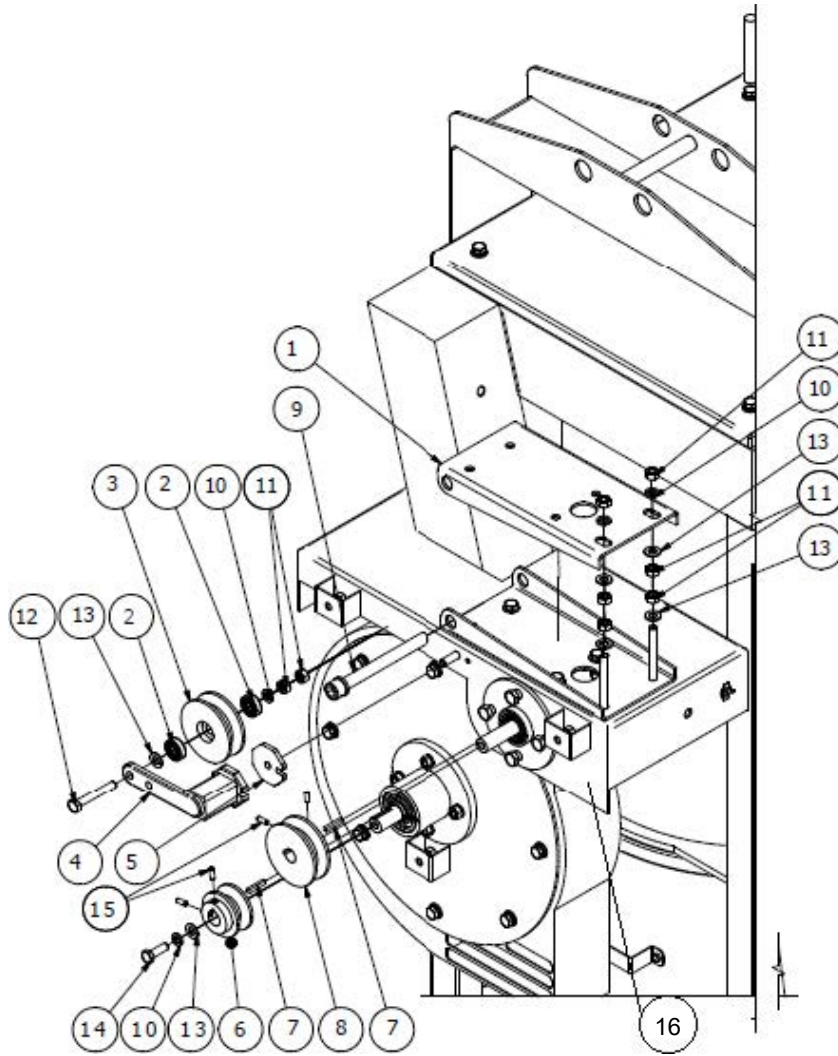

ITEM	DP #	QTY	DESCRIPTION
1	2508857	1	ENGINE STAND UPPER PART
2	2508850	2	NSK 6200 BEARING
3	2508846	1	TENSIONER PULLEY
4	2508848	1	PULLEY TENSIONER
5	2508854	1	TENSIONER WASHER
6	2508868	1	IMPELLER PULLEY
7	2508852	2	KEY 5 x 5
8	2508851	1	SUPPORT PULLEY
9	2508899	1	M16X170 SOC SCREW
10	2508884	4	M10 SPRING WASHER
11	2508886	8	M10 NUT
12	2508898	1	M10X70 BOLT
13	2508885	6	M10 WASHER
14	2508887	1	M10X30 BOLT
15	2508897	4	M6X16 SET SCREW
16	2801502	1	TACHOMETER/HOUR METER (Mounted to Frame)



# Impeller Housing

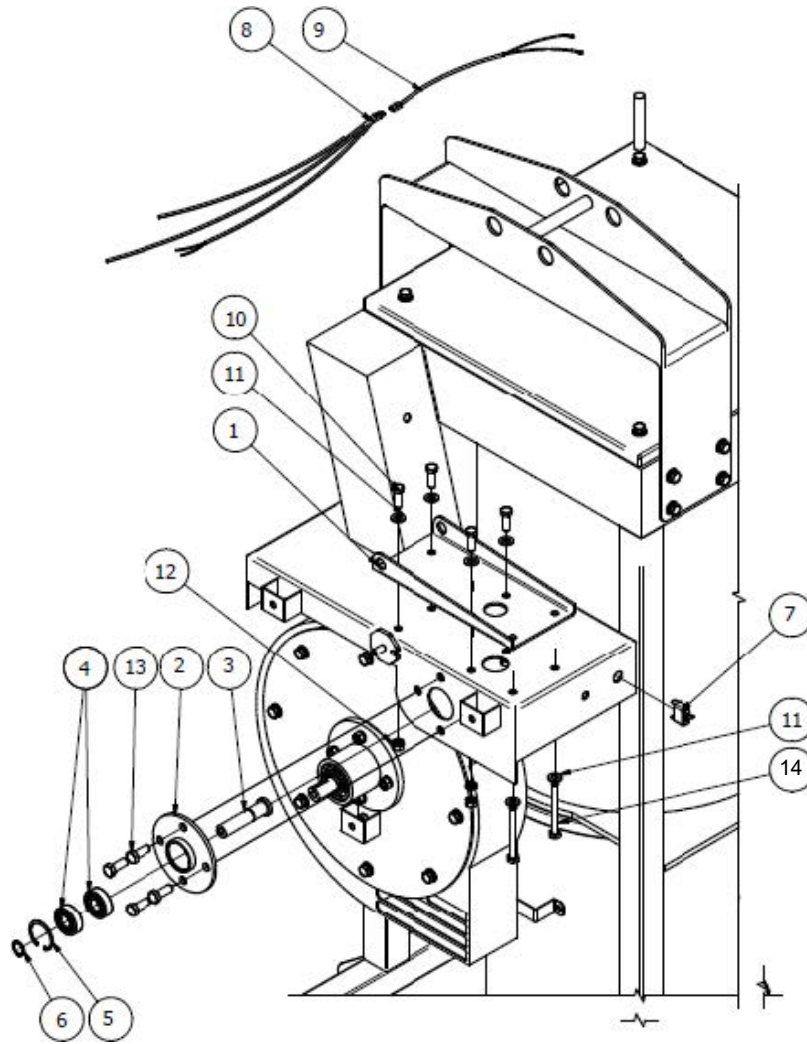

ITEM	DP #	QTY	DESCRIPTION
1	2508858	1	ENGINE STAND BELOW PART
2	2508862	1	ASSISTING PULLEY BEARING HOUSING
3	2508860	1	ASSISTING PULLEY SHAFT
4	2508861	2	BEARING
5	2508855	1	47X1.8 SNAP RING(INSIDE)
6	2508856	1	20X1.2 SNAP RING(OUTSIDE)
7	2508585	1	ON/ OFF SWITCH
8	2508859	1	ENGINE & MOTOR WIRE
9	2508867	1	BATTERY WIRE
10	2508887	4	M10X30 BOLT
11	2508885	4	M10 WASHER
12	2508886	4	M10 NUT
13	2508936	4	M12X30 BOLT SET
14	2508935	2	M10X90 HEX BOLT

# Impeller

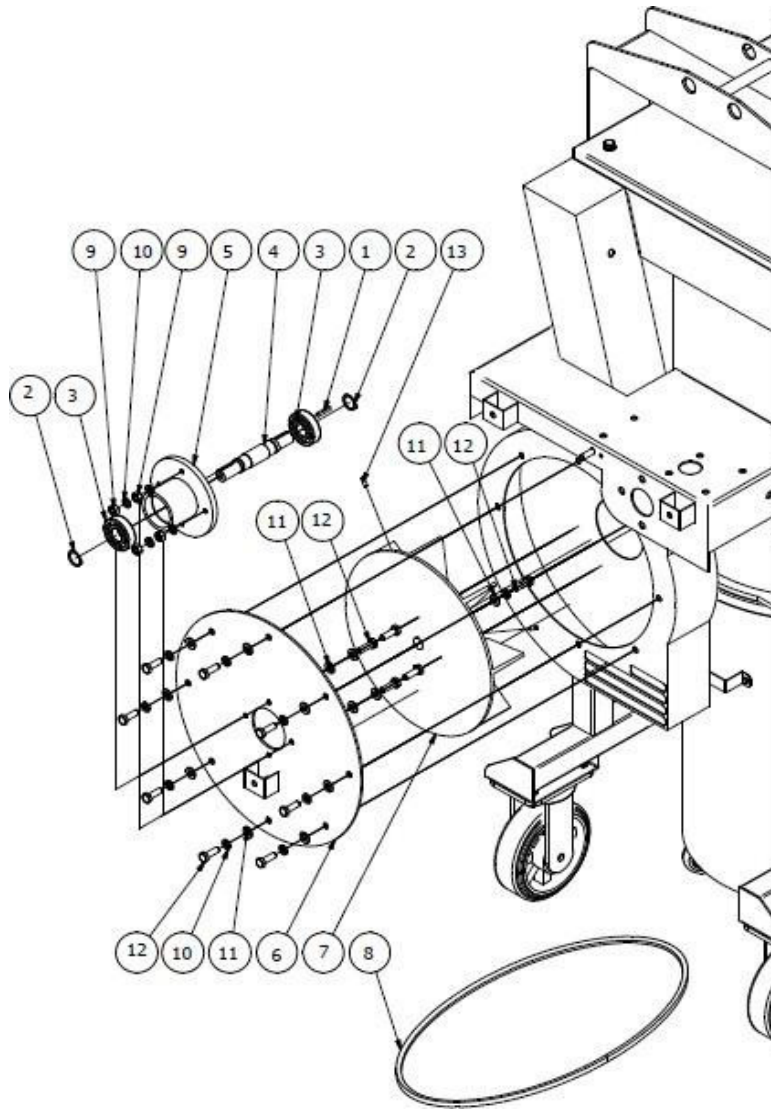

ITEM	DP #	QTY	DESCRIPTION
1	2508852	2	KEY 5 x 5
2	2508876	2	25X1.2 SNAP RING(OUTSIDE)
3	2508869	2	NSK 6305 BEARING
4	2508865	1	IMPELLER SHAFT
5	2508866	2	IMPELLER BEARING HOUSING
6	2508864	1	IMPELLER COVER
7	2508863	2	IMPELLER BLOWER WHEEL
8	2508870	1	BELT B-48
9	2508886	4	M10 NUT
10	2508884	12	M10 SPRING WASHER
11	2508885	16	M10 WASHER
12	2508887	12	M10X30 BOLT
13	2508897	1	M6X16 SET SCREW

# Dust Drum

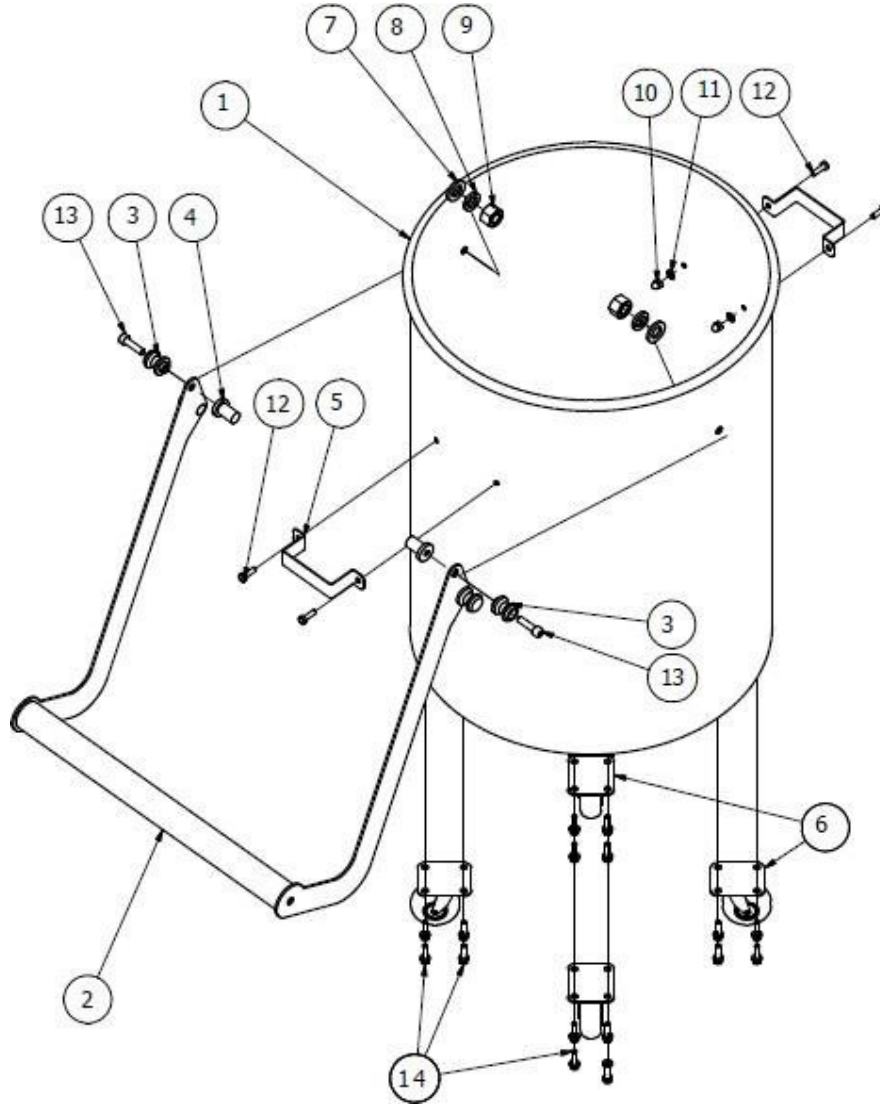

ITEM	DP #	QTY	DESCRIPTION
1	2508874	1	DUST DRUM
2	2508871	1	DUST DRUM LEVER
3	2508873	2	LEVER PARTS
4	2509431	2	LEVER BUSHING
5	2508877	2	DUST DRUM HANDLE
6	2508875	4	DUST DRUM WHEEL 2.5"
7	2508939	2	M16 WASHER
8	2508938	2	M16 SPRING WASHER
9	2508937	2	M16 NUT
10	2508941	4	M6 CAP NUT
11	2508889	4	M6 WASHER
12	2508940	4	M6X20 BOLT SET
13	2508943	2	M8X35 SOC SCREW
14	2508942	16	M6X25 FLANGE NUT

# Hose Inlet

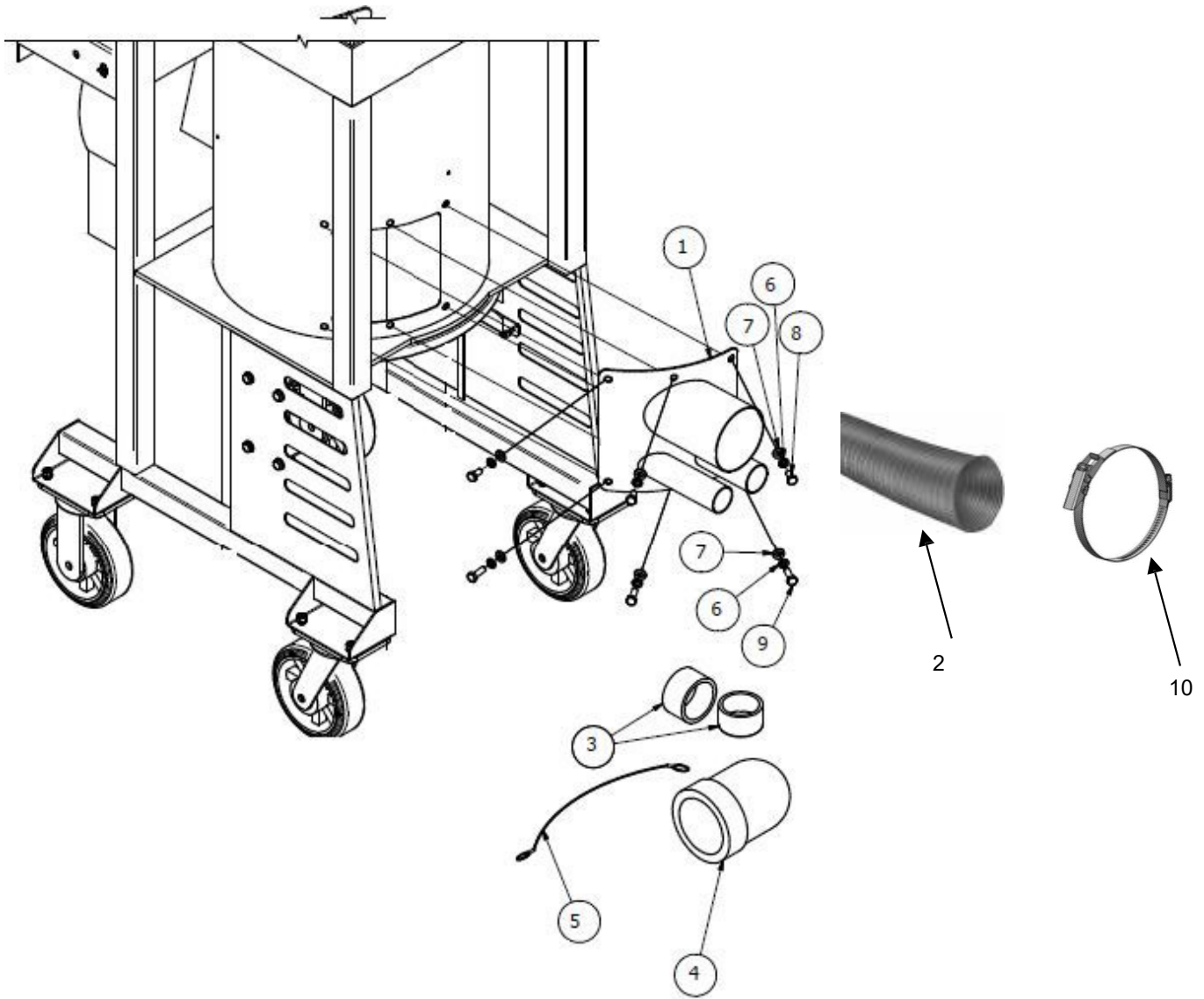

ITEM	DP #	QTY	DESCRIPTION
1	2508878	1	HOSE INLET
2	2505835	1	5"x15' HOSE
3	2509169	2	INLET COVER(SMALL)
4	2508881	1	INLET COVER(LARGE)
5	2508882	1	INLET WIRE
6	2508884	6	M10 SPRING WASHER
7	2508885	6	M10 WASHER
8	2508883	3	M10x20 BOLT
9	2508887	3	M10X30 BOLT
10	2505870	2	5" HOSE CLAMP

# Engine

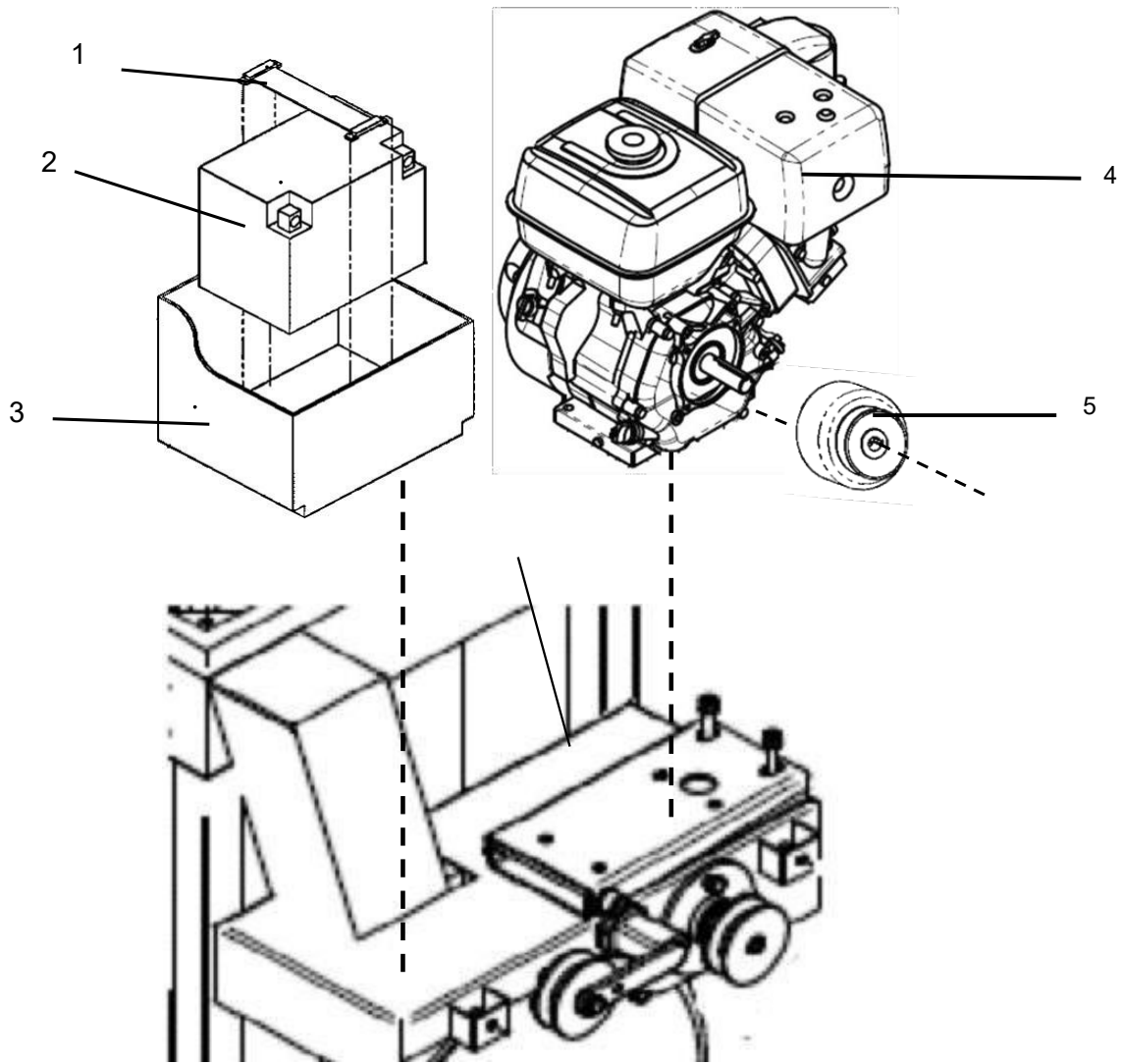

ITEM	DP #	QTY	DESCRIPTION
1	2508934	1	BATTERY STRAP
2	2802378	1	BATTERY
3	2508946	1	BATTERY BOX
	4244139	1	BOX RUBBER
4*	2601110	1	HONDA ENGINE
	2600748	1	VANGUARD ENGINE
5	2505868	1	CLUTCH
	2801029	1	FUSE HOLDER (not shown)
	2801367	1	E-STOP (CVG1-B ONLY) (not shown)
	2509405	1	RECTIFIER ASSEMBLY (not shown)
	2509406	1	SUB-WIRE ASSEMBLY (not shown)
	2509407	1	OIL ALERT UNIT (not shown)
	2509408	2	IGNITION KEY (not shown)
	2703698	1	IGNITION SWITCH AND KEY(not shown)





## **EQUIPMENT AND PARTS WARRANTY**

Diamond Products warrants all equipment manufactured by it against defects in workmanship or materials for a period of one (1) year from the date of shipment to Customer.

The responsibility of Diamond Products under this Warranty is limited to replacement or repair of defective parts at Diamond Products' Elyria, Ohio factory, or at a point designated by it, of such parts as shall appear to us upon inspection at such parts, to have been defective in material or workmanship, with expense for transportation and labor borne by Customer.

In no event shall Diamond Products be liable for consequential or incidental damages arising out of the failure of any Product to operate properly.

Integral units such as engines, electric motors, batteries, transmissions, etc., are excluded from this Warranty and are subject to the prime manufacturer's warranty.

**THIS WARRANTY IS IN LIEU OF ALL OTHER WARRANTIES, EXPRESSED OR IMPLIED, AND ALL SUCH OTHER WARRANTIES ARE HEREBY DISCLAIMED.**



333 Prospect Street, Elyria, Ohio 44035  
(440) 323-4616 • (800) 321-5336 • Fax (800) 634-4035  
[www.diamondproducts.com](http://www.diamondproducts.com)