



**CORE CUT
PARTS LIST**

**TR40 HIGH-CYCLE
RING SAW**

OCTOBER, 2023

Table of Contents

<u>Description</u>	<u>Page No.</u>
1. TR40 Breakdown.....	4
2. TR40 Parts.....	5-8
3. Gearbox.....	9
4. Notes.....	10

Diamond - Ring Saw TYPE TR 40

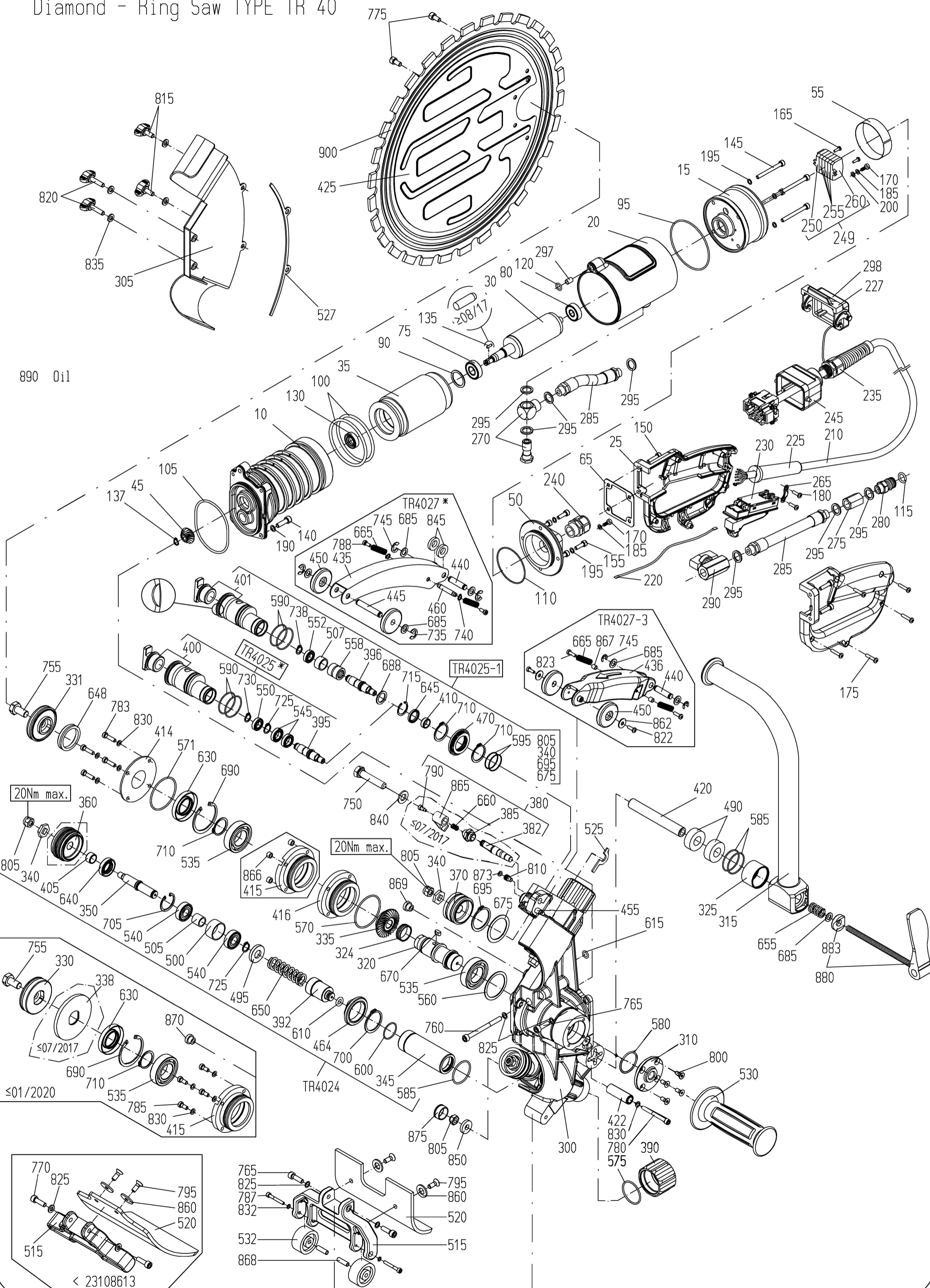

890 Oil

20Nm max.

20Nm max.

≤01/2020

≤07/2017

≤07/2017

< 23108613

TR40 PARTS

FIG	Part #	QTY	DESCRIPTION
10	2708812	1	Motor case
15	2708731	1	Motor Top Case
20	2708732	1	Case Sleeve
25	2707551	1	Switch Handle cpl.
30	2708813	1	Rotor with Bearings
35	2708734	1	Stator cpl.
45	2708816	1	Bevel Gear Set Fig.45+335
50	2708736	1	Motor Top Case Hood incl. Fig. 65. 110
55	2708737	1	Insulation Film
65	2701567	1	Terminal Case Packing
75	2700664	1	Ball Bearing
80	2708738	1	Ball Bearing
90	2700666	1	Compensation Washer
95	2700710	1	O-Ring RDR78X2
100	2708740	2	O-Ring RDR74X4
105	2702498	1	O-Ring RDR72X2
110	2709219	1	O-Ring RDR55X2
115	2700712	1	O-Ring RDR11x2.5
120	2708809	1	O-Ring RDR8x2
130	2703241	1	Rotary Shaft Seal A
135	2708818	1	Parallel Pin
137	2708820	1	Retaining Ring 9x1 > 08
140	2701049	2	Hex. Socket Head Screw M6x20
145	2700732	4	Hex. Socket Head Screw M5x50
150	2707564	4	Hex. Socket Head Screw M5x20
155	2708811	4	Hex. Socket Head Screw M5x16
165	2708744	2	Cheese head screw M3x10
170	2700674	1	Sl. Pan Head Screw M4x6
175	2700676	5	Pan Head Tapping Screw F3.9x19 (BZ)
180	2702986	2	Pan Head Tapping Screw F3.9x13 (BZ)
185	2700680	1	Curved Spring Washer A4
190	2700826	2	Locking Washer SM6
195	2700735	8	Locking Washer SM5
200	2700681	1	Medium Washer 4.3x8x0.5
210	2708815	1	Cord cpl. with male insert. + Fig. 225.235.240.245.298 6G1.5x4.4
220	2709841	1	Switch Strand 1.5²x200
225	2707556	1	Cord Sleeve D12
230	2707533	1	Motor Switch
235	2708747	1	Cord Gland EMV
240	2708748	1	Cord Gland M20x1.56x2.5
245	2708749	1	Hood 6B EMV
249	2709600	1	Terminal Block cpl. with marking (fig.250.255.260)
250	2708750	1	End Terminal Block with Fixing Flange
255	2708751	4	Center Terminal Block
260	2708752	1	End Plate with Fixing Flange
265	2700686	1	Cord Clamping Piece

TR40 PARTS

FIG	Part #	QTY	DESCRIPTION
270	2701094	1	Angle Screwing G 1/4"
275	2703211	1	Socket
280	2700706	1	Quick Connect Nipple
285	2701939	2	Hose Piece cpl. with nipples
290	2707565	1	Ball Valve
295	2700717	7	Sealing Ring G1/4"
297	2708753	1	Fixing Sleeve
298	2708754	1	Protective Hood
300	2708822	1	Gear Box with Guide Bush. Bow Pin. Seals and O-RINGS
305	2708823	1	Cover cpl. with Distance Bush and Fig. 815.820.835
310	2708824	1	Bearing Hood incl. O-Ring fig.580
315	2708825	1	Handle cpl.
320	2703794	1	Spindle With Sleeve
	2708826	1	Spindle
324	2709601	1	Shaft Wearing Sleeve
325	2708761	1	Sleeve
330	2708828	1	Drive Wheel (Old Style)
331	2709843	1	Drive Wheel cpl. with V-Ring (New Style). See Kit below> 02 / 2020
	2709845	1	V-Seal Conversion Kit. (Needed if using 2709843 on saw <02/2020)
335	2708816	1	Bevel Gear Set Fig.45+335 only change as43 a set
340	2708666	4	Hex Washer
	2709603	2	Guide Sleeve cpl. without Guide Roller
345	2708831	2	Guide Sleeve
350	2708832	2	Roller Shaft
360	2708616	2	Guide Roller kpl. incl. Fig. 805
370	2708833	2	Support Roller incl. Fig. 805
390	2708837	2	Knob
392	2708838	2	Pressure Sleeve incl. O-Ring fig.610
395	2708839	2	Roller Shaft (Old Style)
396	2709604	2	Roller Shaft (New Style 2019)
397	2709605	2	Eccentric Shaft cpl. without Support Roller (Old Style)
398	2709310	2	Eccentric Shaft cpl. without Support Roller (New Style)
400	2708840	2	Eccentric Shaft incl. T-Knob (Old Style)
401	2709606	2	Eccentric Shaft incl. T-Knob (New Style 2019)
405	2708841	2	Shaft Wearing Sleeve
410	2708843	2	Shaft Wearing Sleeve
414	2709844	1	Protection disc
415	2708844	1	Bearing Ring incl. O-Ring fig.570
416	2709846	1	Bearing Ring incl. O-Ring fig.570
420	2708769	1	Handle Axle
422	2708845	1	Stop Sleeve
425	2708771	1	Guide Blade
	2709898	1	Guard Bow cpl.
436	2709899	1	Guard Bow (short)
440	2708847	1	Bow Axle
445	2708848	1	Bow Axle
450	2708849	2	Bow Wheel

TR40 PARTS

FIG	Part #	QTY	DESCRIPTION
455	2709612	1	Bow Pin
460	2708850	1	Bow Pin
464	2708851	2	Protection Sleeve cpl.
470	2708853	2	Protection Sleeve cpl. w. O-Rings fig.595
490	2708852	2	Adjust Sleeve
495	2708854	2	Pressure Disk
500	2708855	2	Distance Sleeve
505	2708856	2	Distance Sleeve
507	2709608	2	Distance Sleeve
515	2710233	1	Stand
520	2710234	1	Splash Guard
525	2708859	1	Seal
527	2709609	1	Housing seal
530	2700707	1	Handle
532	2710235	2	Roller
535	2702478	2	Ball Bearing 6005
540	2700664	4	Ball Bearing 6001ZZ
545	2708860	4	Ball Bearing 6801ZZ
550	2708861	2	Ball Bearing 6800ZZ
552	2709610	2	Ball Bearing 698ZZ
558	2709611	2	Needle Bearing NK12/16
560	2708862	1	Compensation Washer
570	2708863	1	O-Ring RDR 50x2
571	2709847	1	O-Ring RDR 50x1.5
575	2702502	2	O-Ring RDR 34x2
580	2708864	1	O-Ring RDR 32x2
585	2701866	4	O-Ring RDR 32x1.5
590	2702503	4	O-Ring RDR 30x1.5
595	2708865	4	O-Ring RDR 25x1
600	2700668	2	O-Ring RDR 24x1.5
610	2708867	2	O-Ring RDR 8X3
615	2708809	1	O-Ring RDR 8x2
630	2702493	1	Rotary Shaft Seal RWD25x47x
640	2708869	2	Rotary Shaft Seal RWD15x28x
645	2708870	2	Rotary Shaft Seal RWD15x21x
648	2709848	1	V-Ring
650	2708871	2	Pressure Spring 2.8x16.1x65
655	2708779	1	Pressure Spring 2.0x12.5x22.5
665	2708873	2	Extension Spring 1.0x7.0x30
670	2700815	1	Parallel Pin A5x5x10
675	2708874	2	Shim Ring PS35x45x1
685	2708781	5	Shim Ring PS8x14x1
688	2709613	2	Supporting Disk SS15x21x1.5
690	2700729	1	Retaining Ring J47x1.75
695	2708875	2	Retaining Ring A35x1.5
700	2708876	2	Retaining Ring A32x1.5
705	2708877	2	Retaining Ring J28x1.2
710	2700728	5	Retaining Ring A25x1.2
715	2708878	2	Retaining Ring JV21x1

TR40 PARTS

FIG	Part #	QTY	DESCRIPTION
725	2705400	4	Retaining Ring A12x1
730	2707563	2	Retaining Ring A10x1
735	2708880	2	Retaining Ring > 04 / 18
	2708743	2	Retaining Ring < 04 / 18
738	2708743	2	Retaining Ring A8x0.8
740	2708879	2	Retaining Ring A6x0.7
745	2708880	4	Retaining Ring RA6
750	2708881	2	Hexagon Head Screw M10x50
755	2708603	1	Hexagon Head Screw
760	2708883	1	Hex. Socket Head Screw M6x70
765	2701049	1	Hex. Socket Head Screw M6x20
770	2702370	2	Hex. Socket Head Screw M6x16
775	2708800	2	Hex. Socket Head Screw M6x12
780	2708694	1	Hex. Socket Head Screw M5x45
783	2709849	4	Hex. Socket Head Screw M5x20
785	2708884	4	Hex. Socket Head Screw M5x12
787	2710236	2	Hex. Socket Head Screw M4x30
788	2708885	2	Hex. Socket Head Screw M4x10
795	2708887	2	Count. Head Screw M6x16
800	2702528	4	Count. Head Screw M5x12
805	2708667	5	Hexagon Nut with torque insert M8
810	2708888	2	Hex. Socket Set Screw with dog point M8x12
815	2708889	2	Wing Screw M6x15
820	2708890	2	Wing screw M6x25
822	2700675	2	Pan Head Tapping Screw F3.9x9.5
823	2709850	2	Pan Head Tapping Screw F3.5x13
825	2700826	4	Locking Washer SM6
830	2700735	5	Locking Washer SM5
832	270		Locking Washer
835	2708892	4	Curved Spring Washer B6
840	2708893	2	Medium Washer A10.5
845	2708894	2	Medium Washer (PE) 10.5x20x4
850	2708784	1	Medium Washer 8.4x21x4
860	2708893	1	Medium Washer A10.5
	2702983	2	Medium Washer 6.6x22x2
862	2709851	2	Medium Washer 4.3x12x1
866	2709852	4	Distance Sleeve 5.2/8x5
867	2709853	2	Distance Sleeve 4.5/6x6
868	2710237	2	Distance Sleeve 4.5/6x20
869	2709854	1	Rubber Grommet
870	2708896	1	Rubber Grommet
875	2708897	1	Plug
880	2708785	1	Cam Lever cpl. with Pressure Disc M8
	2708806	1	Male Insert without Male Contacts 10P (Not Shown)
	2708807	5	Male Contact 1.5 ² (Not Shown)
	2708901	1	Face Pin Wrench 35x5 (Not Shown)
	2708902	1	Box Wrench SW 17 (Not Shown)
	2708899	1	Coding Bridge (Not Shown)
	2708898	1	Gear Oil 30ml (Not Shown)

GEARBOX HOUSING

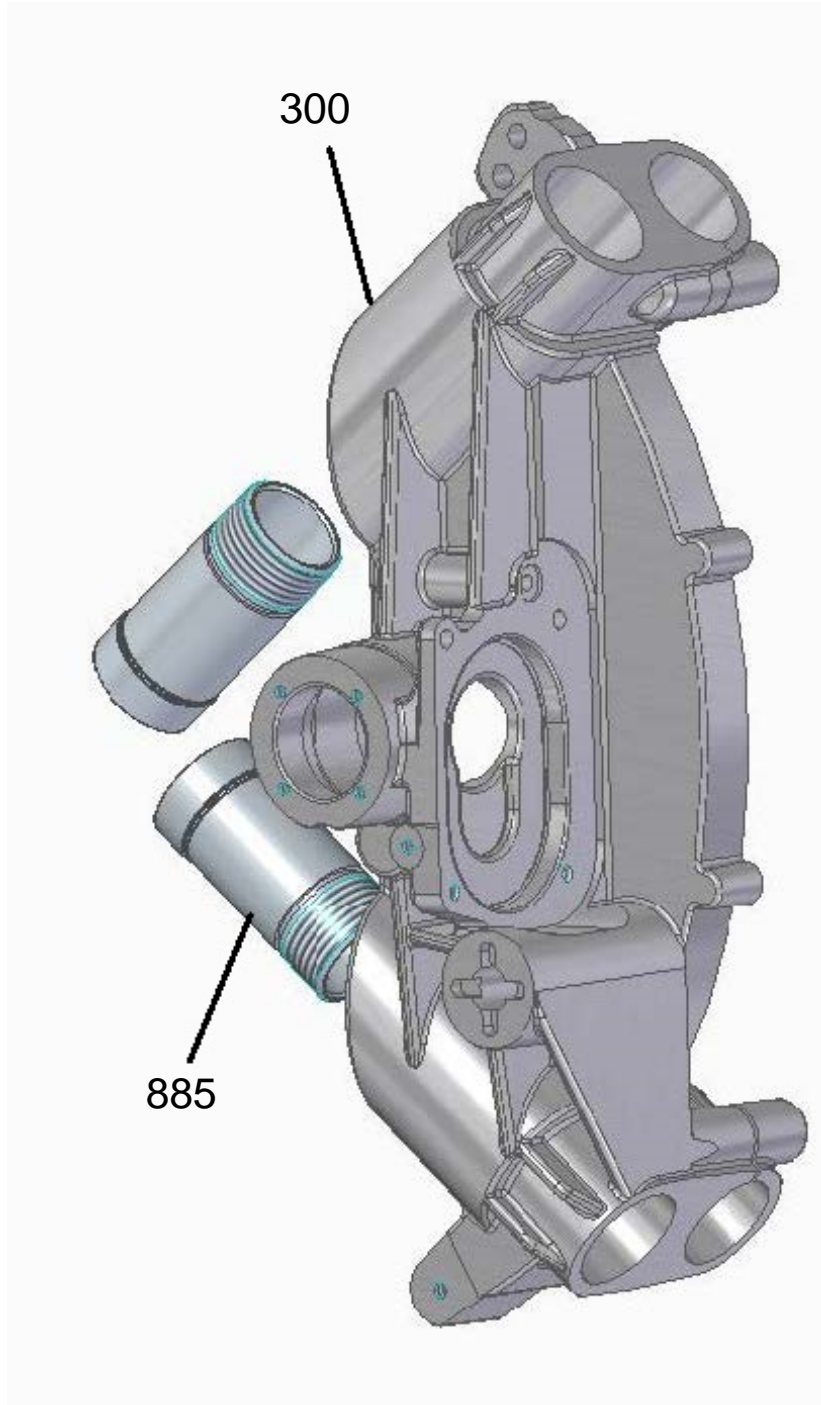

FIG	Part #	QTY	DESCRIPTION
300	2708822	1	Gear Box with Guide Bush. Bow Pin. Seals and O-rings
885	2710229	2	Set Bushing, Includes fig. 575 and 585

EQUIPMENT AND PARTS WARRANTY

Diamond Products warrants all equipment manufactured by it against defects in workmanship or materials for a period of one (1) year from the date of shipment to Customer.

The responsibility of Diamond Products under this Warranty is limited to replacement or repair of defective parts at Diamond Products' Elyria, Ohio factory, or at a point designated by it, of such parts as shall appear to us upon inspection at such parts, to have been defective in material or workmanship, with expense for transportation and labor borne by Customer.

In no event shall Diamond Products be liable for consequential or incidental damages arising out of the failure of any Product to operate properly.

Integral units such as engines, electric motors, batteries, transmissions, etc., are excluded from this Warranty and are subject to the prime manufacturer's warranty.

THIS WARRANTY IS IN LIEU OF ALL OTHER WARRANTIES, EXPRESSED OR IMPLIED, AND ALL SUCH OTHER WARRANTIES ARE HEREBY DISCLAIMED.



333 Prospect Street, Elyria, Ohio 44035
(440) 323-4616 • (800) 321-5336 • Fax (800) 634-4035
www.diamondproducts.com